

ZCV (Zone Control Valve) (Zone Control Stations) Floor Control Valves

1. OS and Y Gate Valve
2. Tamper Switch (Supervision Switch)
3. Check Valve
4. Test and Drain Valve
5. Pressure Gauge
6. Water Flow Switch
7. Pressure Reducing Valve

Zone Control Station

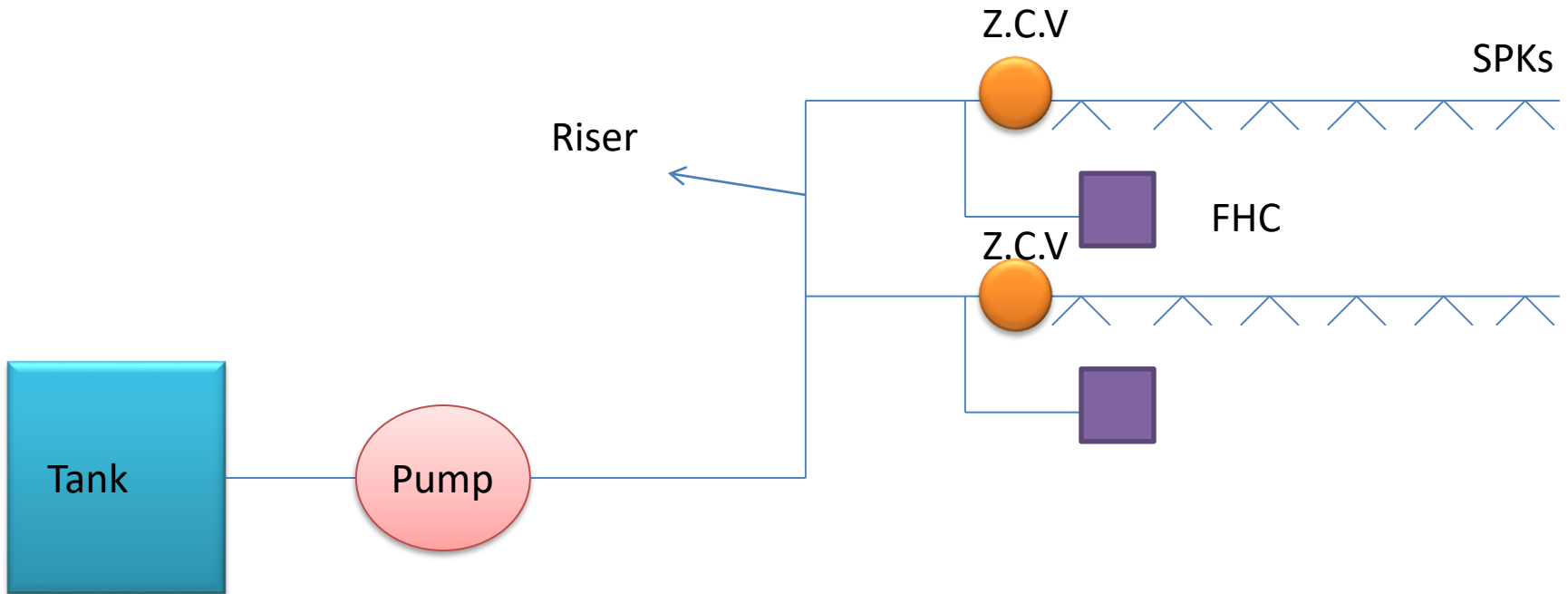

Z.C.V is used to :-

- Isolate the piping network of the floor form the whole system.
- Give alarm if the gate valve is closed.
- Check the flow rate in the system.
- OS & Y valve with tamper switch.

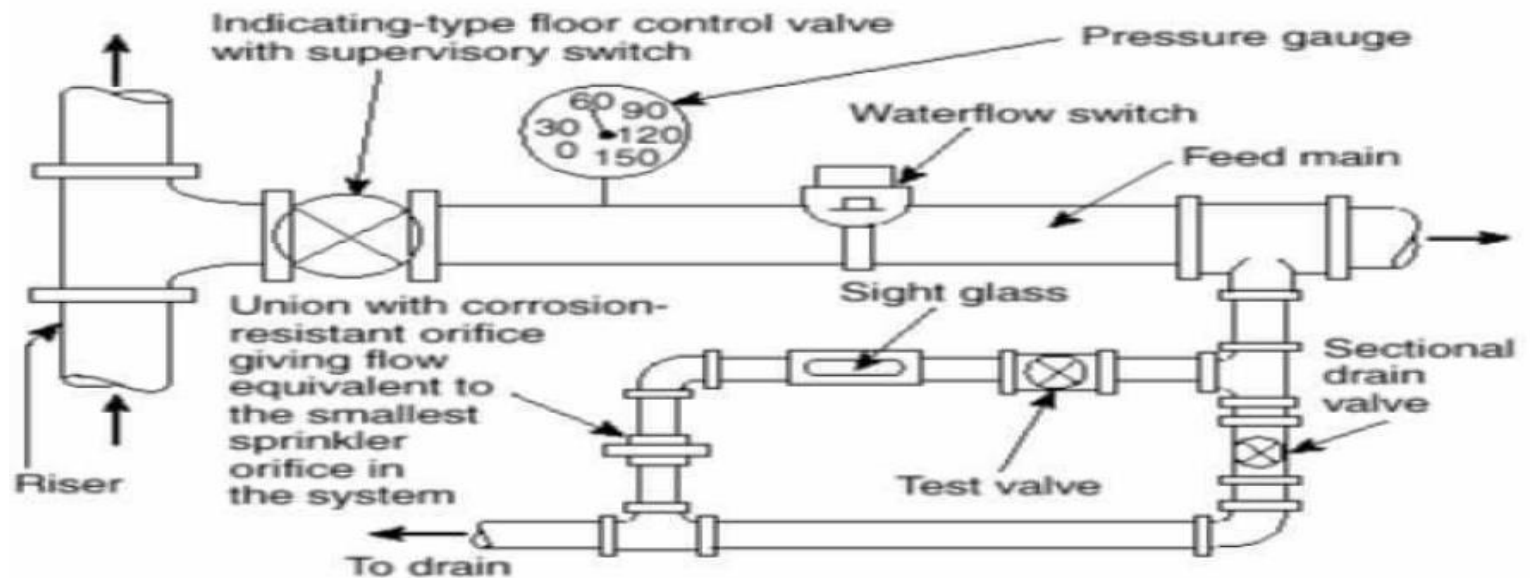
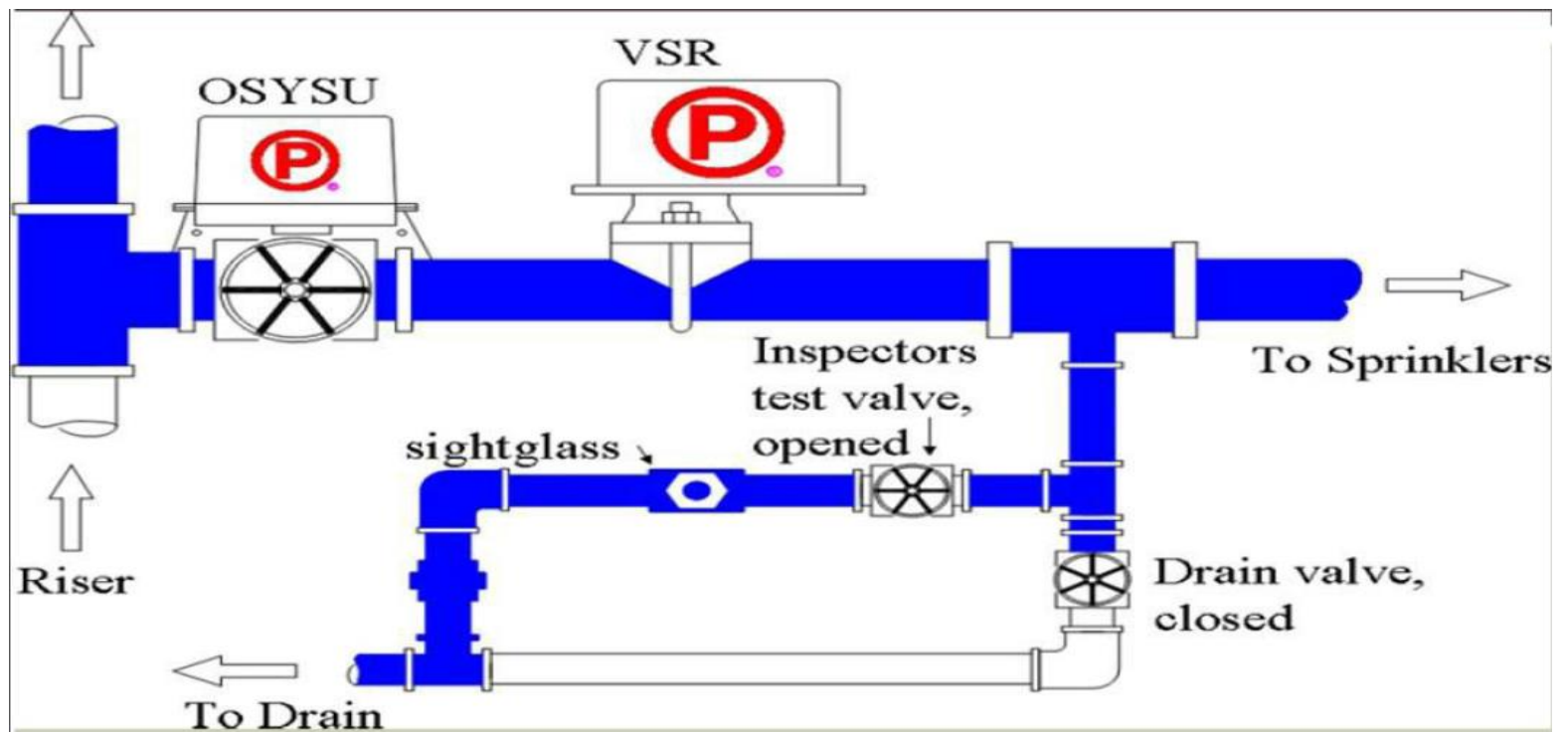

Components

1. OS and Y Gate Valve (Outside Stem & Yoke)



opened



closed



- Butterfly valve

2. Tamper Switch



- Chain with lock



3. Check Valve (Non – Return Valve)



4. Water Flow Switch or Water Flow Detector



5. Pressure Gauge



6. Test and Drain Valve

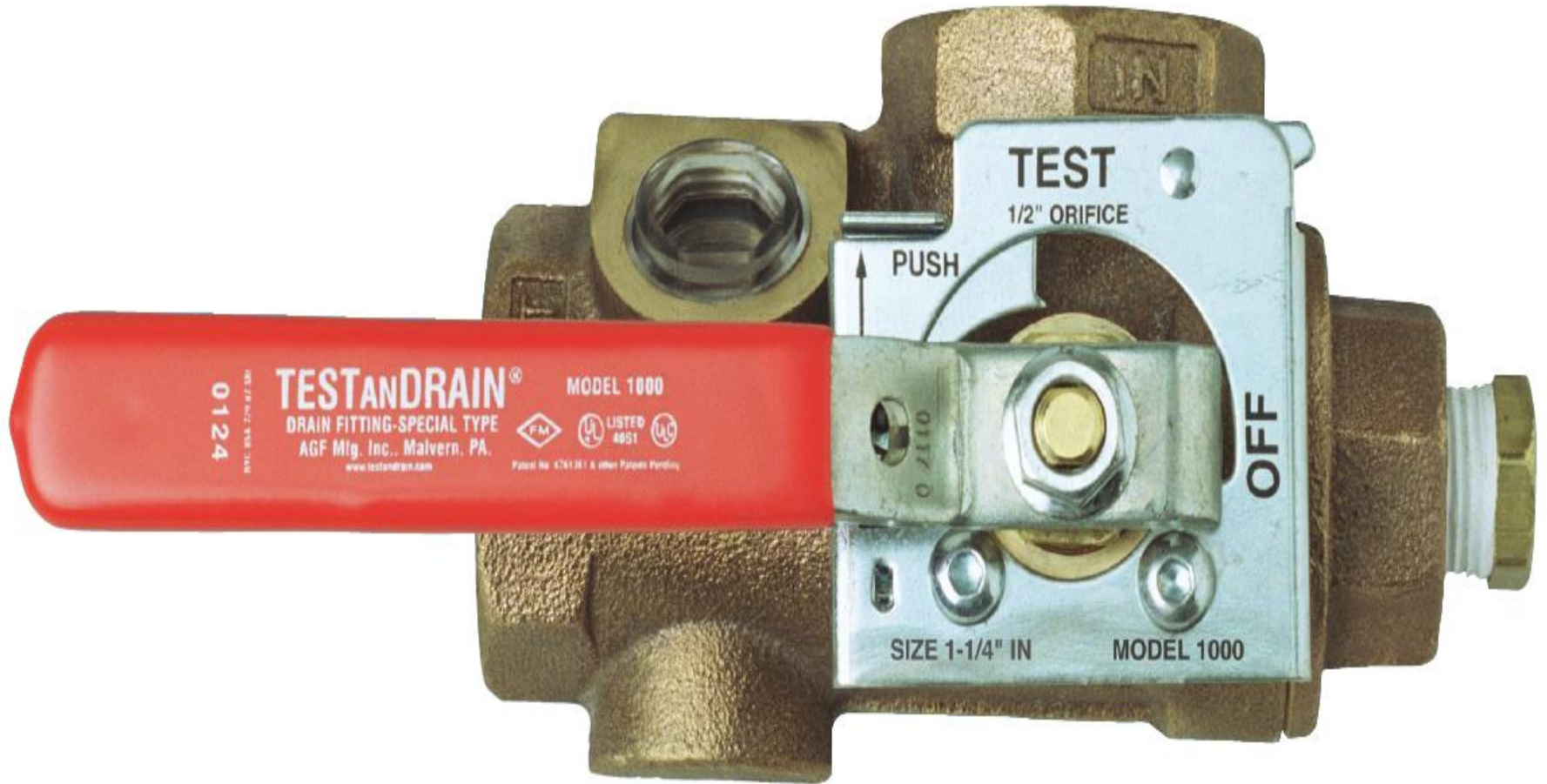

- Riser Size

Riser or Main Size	Size of Drain Connection
UP to 2 in	¾ in or Larger
2.5 in, 3 in, 3.5 in	1 ¼ in or Larger
4 in or Larger	2 in Only

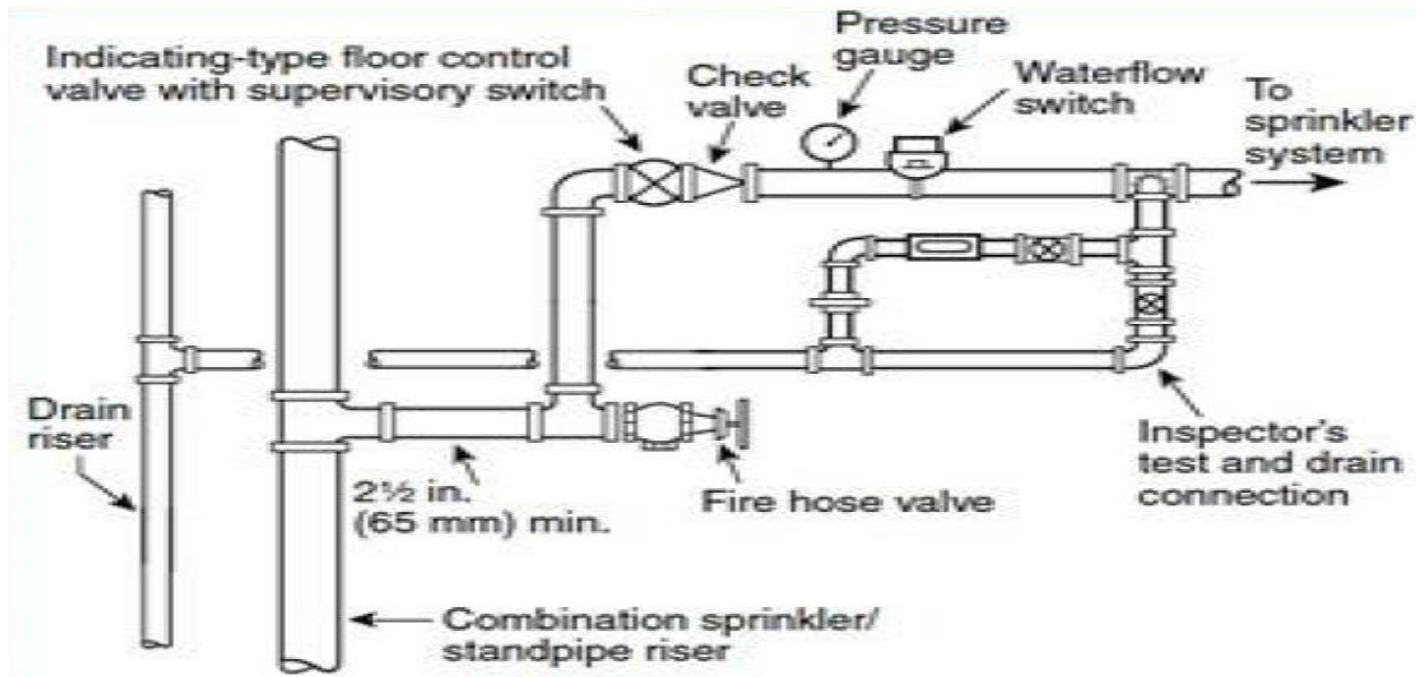

- Pressure Reducing Valve



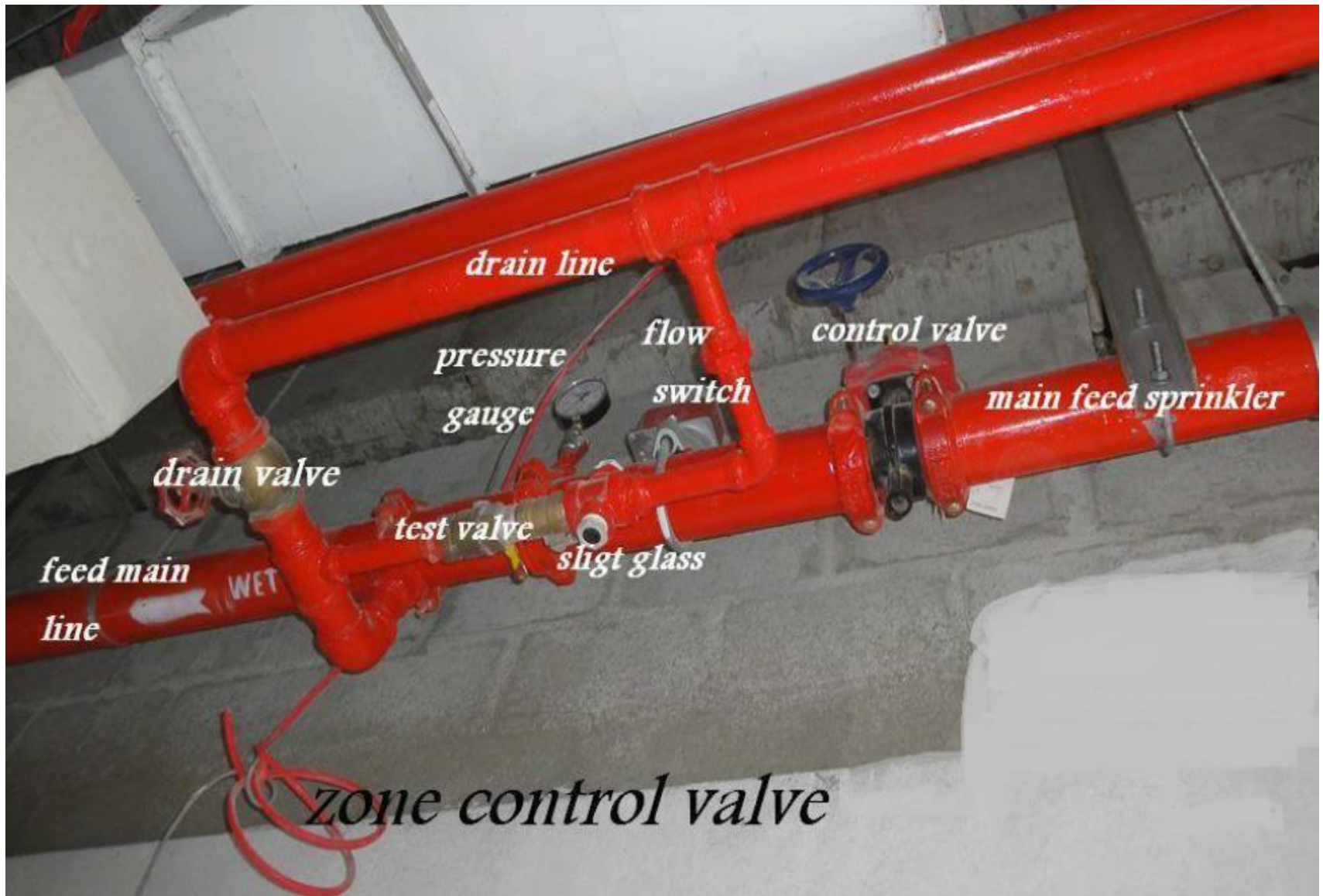

drain line

*pressure
gauge*

*flow
switch*

control valve

main feed sprinkler

drain valve

test valve

sligt glass

*feed main
line*

WET

zone control valve

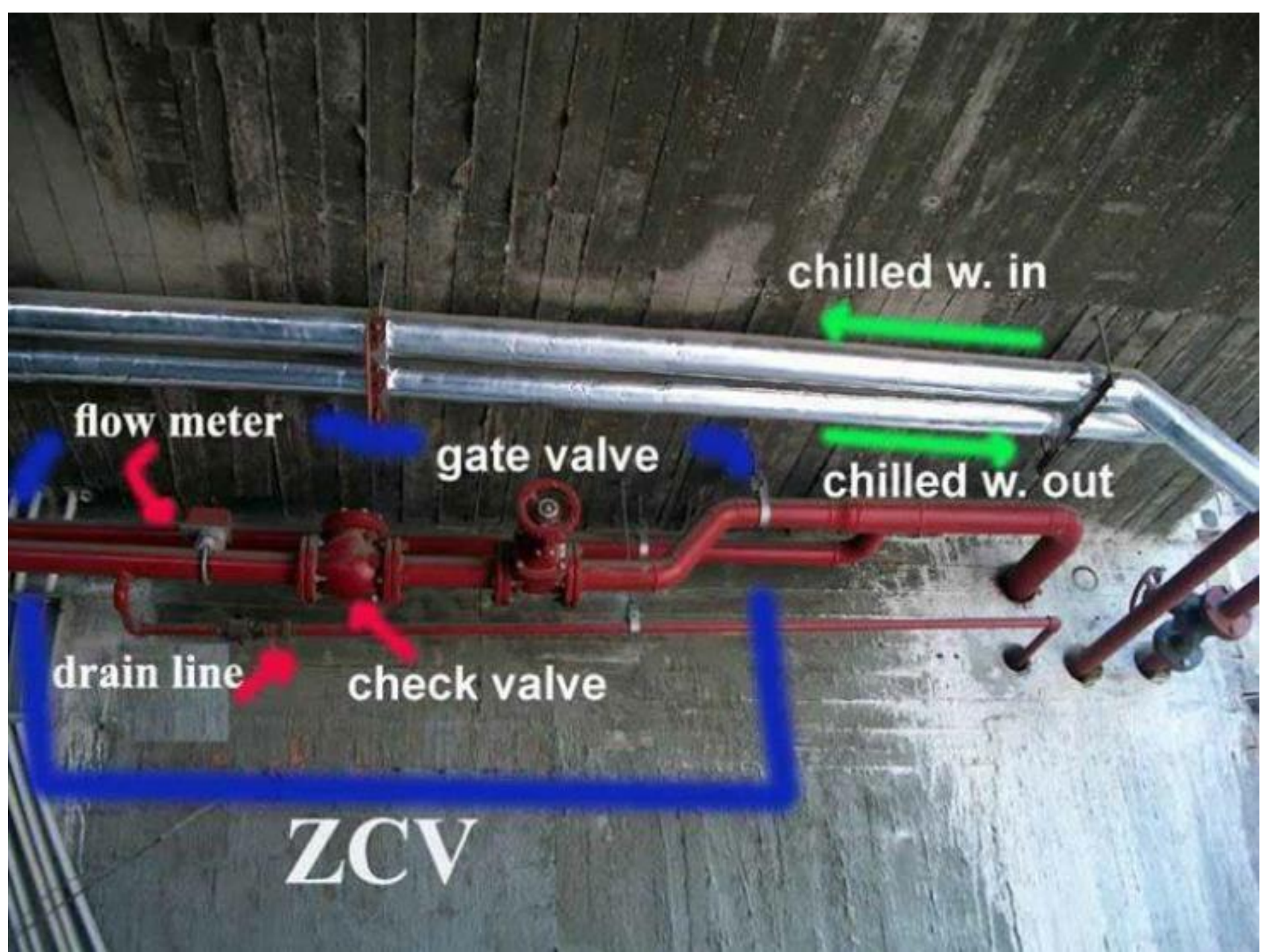

chilled w. in

flow meter

gate valve

chilled w. out

drain line

check valve

ZCV

- Back Flow Prevention



- Fire Pump Test Header

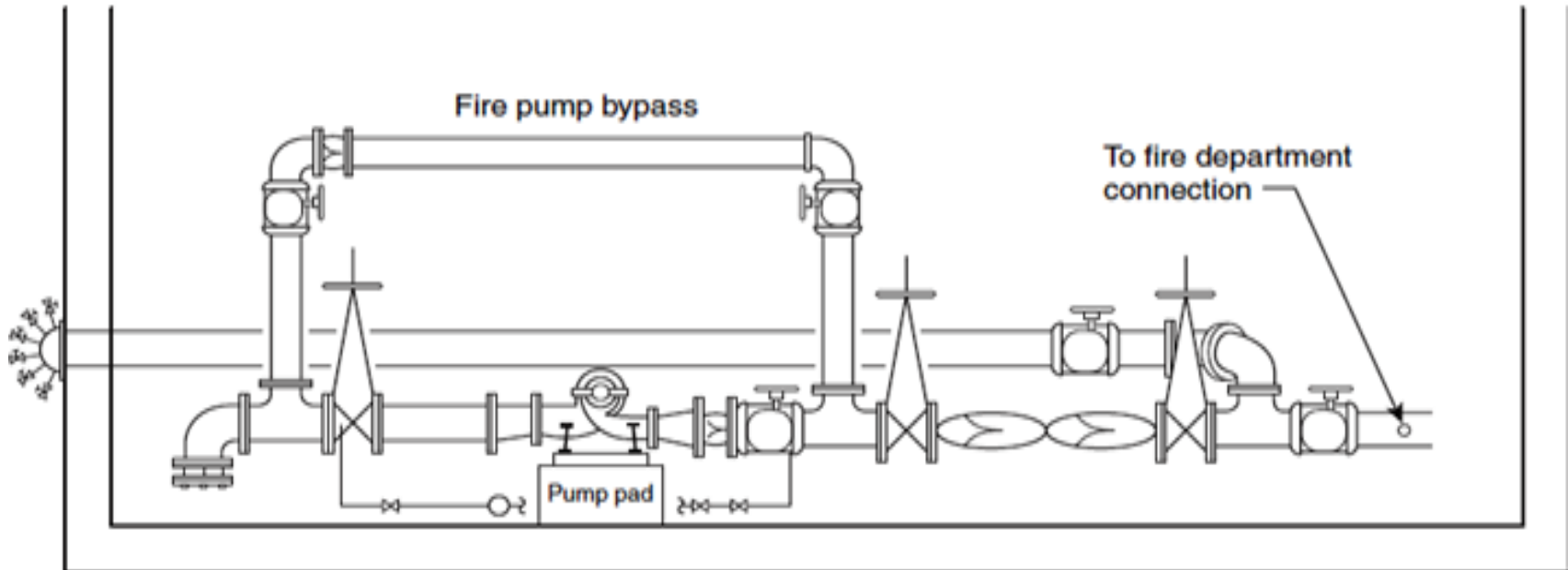

- Pressure Relief Valve

