

Wet Pipe System

- **Components**

1. Fire water tank
2. Fire pumps
3. Control valve (Alarm Check Valve “ ACV^{SPKs} ”)
4. SPKs

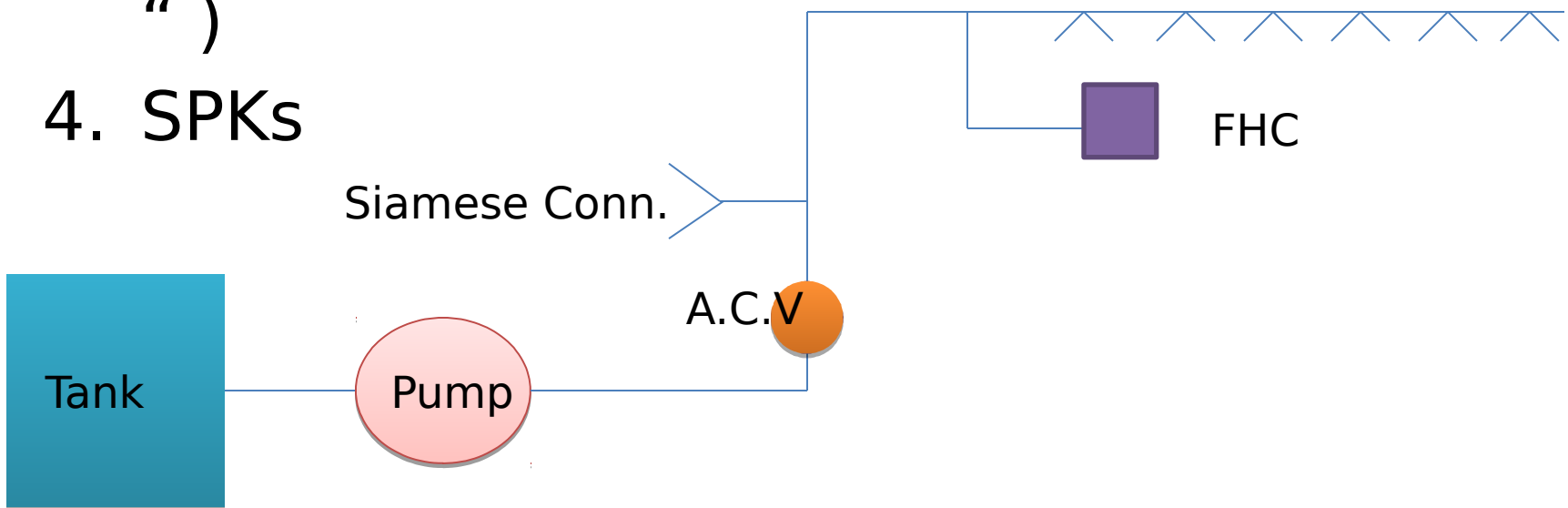

Operation

- A.C.V



الجرس القرصي المائي

Water Motor Gong



Dry Pipe System

- **Components**

1. Water Tank
2. Pumps
3. D.P.V
4. Dry SPKs

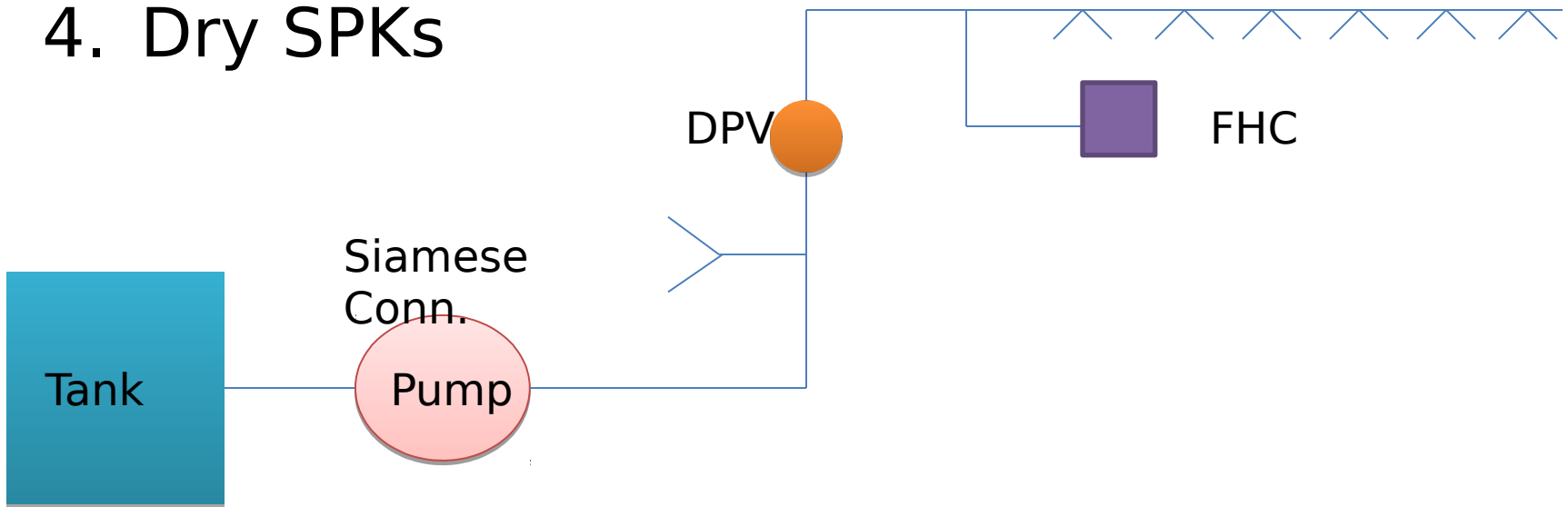

Operation

- **D.P.V**

