



®

Innovative Technology

INTELLIGENCE IN VALIDATION



NV200 Range
[GA02031]



USER MANUAL

NV200 Family User Manual

[<< Back to Contents](#)

Document Name:	NV200 Family User Manual
Document Version:	1.0
Date of Release:	01/09/2017

TABLE OF CONTENTS

1	DOCUMENT INTRODUCTION	5
1.1	RELATED DOCUMENTS	5
1.2	MANUAL AMENDMENTS.....	5
1.3	COPYRIGHT	5
1.4	LIMITED WARRANTY	5
1.5	PRODUCT SAFETY INFORMATION	6
2	PRODUCT INTRODUCTION	8
2.1	GENERAL DESCRIPTION.....	8
2.2	KEY FEATURES	8
2.3	TYPICAL APPLICATIONS	8
2.4	COMPONENT OVERVIEW	9
2.4.1	<i>Interface connectors</i>	10
2.4.2	<i>User Interfaces</i>	11
2.4.2.1	Dip Switches on the NV200.....	11
2.4.2.2	Dip Switches on the Payout module	11
2.4.2.3	Smart Ticket Button	11
2.4.2.4	Smart Ticket Dip Switches.....	12
2.4.3	<i>Bezel Options</i>	14
2.4.4	<i>Cashbox Options</i>	14
2.4.5	<i>Module Options</i>	14
2.4.6	<i>Consumables</i>	14
3	TECHNICAL DATA.....	15
3.1	DIMENSIONS	15
3.2	WEIGHT	15
3.3	ENVIRONMENTAL REQUIREMENTS	15
3.4	POWER REQUIREMENTS	16
3.4.1	<i>Supply Voltages</i>	16
3.4.2	<i>Supply Currents</i>	16
3.4.3	<i>Power Supply Guidance</i>	16
3.5	INTERFACE LOGIC LEVELS	17
3.5.1	<i>Opto-Isolated Inputs</i>	17
3.6	RELIABILITY DATA.....	17
3.7	MEDIA REQUIREMENTS	17
3.8	COMPLIANCES AND APPROVALS	18
3.8.1	<i>EC Declaration of Conformity</i>	18
3.8.2	<i>Central Bank Approval</i>	18
4	MECHANICAL INSTALLATION	19
4.1	COMPATIBILITY	19
4.1.1	<i>Hardware Compatibility</i>	19
4.1.1.1	Machine Mounting	19
4.1.1.2	Machine Interfacing.....	19
4.1.1.3	Power Supply	19
4.1.2	<i>Software Compatibility</i>	19
4.1.2.1	Interface Protocols.....	19
4.1.2.2	Re-programming.....	19
4.2	BEZEL MOUNTING.....	20



NV200 Family User Manual

[<< Back to Contents](#)

4.2.1	Bezel Fitting	20
4.3	CASHBOX REMOVAL.....	21
4.3.1	Standard Cashbox Removal	21
4.3.2	TEBS Cash Bag Removal & Replacement	21
4.4	LOADING PAPER INTO THE SMART TICKET	22
4.4.1	Roll	22
4.4.1.1	Top	22
4.4.1.2	Rear	23
4.4.1.3	Top	23
4.4.1.4	Rear	24
4.5	LOCK MOUNTING.....	25
4.5.1	Lock Fitting – NV200	25
4.5.2	Lock fitting – Standard Cashbox	27
4.5.3	Lock Fitting - TEBS Cashbox	28
4.5.4	Lock Specifications	28
4.5.5	Lock Cam.....	28
4.6	MACHINE MOUNTING.....	28
4.6.1	Machine Mounting - Standard Cashbox	29
4.6.2	Machine Mounting – TEBS.....	29
4.6.3	Things to consider.....	29
4.6.4	Earth Bonding	29
4.6.5	Screw Specifications.....	30
5	PROTOCOLS AND INTERFACING.....	31
5.1	INTRODUCTION	31
5.2	SSP	31
5.2.1	General Description	31
5.2.2	Pin Assignments	31
5.2.3	Setup Examples	32
5.2.3.1	NV200	32
5.2.3.2	NV200 – TEBS Cashbox	32
5.2.3.3	NV200 with Payout Module (SPO)	33
5.2.3.4	NV200 TEBS with Payout Module (TEBS SPO).....	34
5.2.3.5	NV200 with Ticket Module (SMART Ticket)	34
5.2.3.6	NV200 TEBS with Ticket Module (TEBS SMART Ticket).....	35
5.3	ccTALK®	36
5.3.1	General Description	36
5.3.2	Pin Assignments	36
5.3.3	ccTalk® DES Encryption.....	36
5.3.4	ITL Specific Implementations	36
5.3.4.1	CC1.....	36
5.3.4.2	CC2.....	36
5.3.5	Setup Example Drawing/s.....	37
5.3.5.1	NV200	37
5.3.5.2	NV200 with Payout Module (SPO)	37
5.4	SIO AND SI2	38
5.4.1	General Description	38
5.4.2	Pinout.....	39
5.5	MDB.....	40
5.5.1	General Description	40
5.5.2	Pinout.....	40
5.5.3	IF5 Interface	40
5.6	PULSE	41
5.6.1	General Description	41
5.6.2	Pinout.....	41
5.6.3	Inhibit Control	41
5.6.4	Escrow Control	41
5.6.5	Busy Control	42
5.6.6	Low Power Mode	42
5.6.7	Credit Hold Function	42



NV200 Family User Manual

[<< Back to Contents](#)

5.6.8	IF15 Interface	43
6	SOFTWARE INSTALLATION AND CONFIGURATION	44
6.1	INTRODUCTION	44
6.2	SOFTWARE DOWNLOADS	44
6.2.1	Drivers	44
6.3	DATASET/FIRMWARE PROGRAMMING	44
6.3.1	Validator Manager	44
6.3.1.1	General Description	44
6.3.1.2	System Requirements	45
6.3.1.3	Hardware Setup	45
6.3.1.4	Switching to Programming Mode (SSP)	45
6.3.1.5	Programming the device	45
6.3.2	DA3	46
6.3.2.1	General Description	46
6.3.2.2	System Requirements	46
6.3.2.3	Re-programming the DA3	47
6.3.3	SD Card	48
6.3.3.1	General Description	48
6.3.3.2	System Requirements	48
6.3.3.3	Re-programming via SD Card	48
6.3.4	Remote Updates	48
6.3.5	SMART Update	49
7	ROUTINE MAINTENANCE	50
7.1	INTRODUCTION	50
7.2	CLEANING THE NV200	50
7.2.1	Recommended Cleaning Intervals	50
7.2.2	Cleaning the Validator	50
7.2.3	Cleaning the TEBS Cashbox	51
7.2.4	Cleaning the Ticket Module	53
8	FIRST LEVEL SUPPORT	57
8.1	BEZEL LED FLASH CODES	57
8.2	NV200 MODULE FLASH CODES	59
8.2.1	TEBS Lock Flash Codes	59
8.2.2	Payout Module Flash Codes	59
8.2.3	Ticket Module Flash Codes	60
8.3	CHECKING POWER CONNECTIONS TO THE UNIT	60
8.3.1	NV200 Connections	61
8.3.2	TEBS Connections:	61
8.3.3	Smart Payout Connection:	62
8.3.4	Smart Ticket Connection:	62
8.3.5	Checking the Supply Voltage	62
8.4	COMMUNICATION WITH THE HOST	62
9	SECOND LEVEL SUPPORT	64
9.1	CLEARING A JAM WITHIN THE NV200	64
9.1.1	Note is in the note path	64
9.1.2	Note is visible once the NV200 has been removed	64
9.1.3	Note isn't visible once the NV200 has been removed	65
9.1.3.1	Clearing a Jam from the Standard Cashbox	65
9.1.3.2	Clearing a Jam from the TEBS Cashbox	66
9.2	CLEARING A JAM FROM THE PAYOUT MODULE	67
9.3	DIVERTER AND TAPE POSITIONS IN THE PAYOUT MODULE	70
9.4	CLEARING A JAM FROM THE TICKET MODULE	70
9.5	DIAGNOSTIC TOOLS	70
9.5.1	Running unit diagnostics	71
9.5.2	Testing the mechanical operation	71
9.5.3	Re-initialisation of the sensors	72



NV200 Family User Manual

[<< Back to Contents](#)

9.6	TESTING AFTER AN ERROR HAS BEEN CLEARED	73
10	APPENDIX	74
10.1	2D DRAWINGS.....	74
10.1.1	NV200.....	74
10.1.2	NV200 with Payout module	75
10.1.3	NV200 with Ticket module	76
10.1.3.1	Fan-fold Rear.....	76
10.1.3.2	Fan-fold Top.....	77
10.1.3.3	Roll Rear.....	78
10.1.3.4	Roll Top.....	79
10.1.4	NV200 with TEBS Cashbox	80
10.2	ENERGY PROFILES.....	82
10.2.1	NV200 Standard Cashbox.....	82
10.2.1.1	12 Volts	82
10.2.2	NV200 with Payout Module	83
10.2.2.1	12 Volts	83
10.2.2.2	24 Volts	88
10.2.3	NV200 with Ticket module	92
10.2.4	NV200 with TEBS Cashbox	96
10.3	LOCK SPECIFICATIONS.....	104
10.3.1	NV200 Locking CAM.....	104
10.3.2	TEBS Locking CAM.....	105
10.4	CABLE DRAWINGS	106
10.4.1	CN214.....	106
10.4.2	CN292.....	107
10.4.3	CN345.....	108
10.4.4	CN389.....	109
10.4.5	CN398.....	110
10.4.6	CN414.....	111
10.4.7	CN487.....	112
10.4.8	WR147.....	113
10.5	SWITCHING TO PROGRAMMING MODE (SSP)	114
10.6	CHANGING THE CASHBOX FLAG IN THE NV200.....	114
10.7	FREE FALL CASHBOX ADVICE.....	114
10.8	CCTALK DES ENCRYPTION – TRUSTED MODE.....	114
10.9	ESCROW	114
10.9.1	Multi-Escrow	114
10.10	ST PROCESSOR PCN	115
10.10.1	NV200.....	115
10.10.2	Smart Payout.....	117
10.11	FILE NAMING CONVENTION.....	119



1 DOCUMENT INTRODUCTION

1.1 Related Documents

This document should be read together with the following documents:

For SSP/eSSP:

[Protocol Manual – SSP \(GA138\): SSP Interface Protocol Specification for integration](#)

[eSSP Implementation Guide \(GA973\): Information for programmers and integrators](#)

[CC2 Manual \(GA00863\): CC2 Interface Protocol Specification for integration](#)

For Software:

[Software Manual – GA02037 Software Guide](#)

1.2 Manual Amendments

Rev.	Date	Amendment Details	Issued by
1.0	01/09/2017	First Issue	JB

1.3 Copyright

This manual set is Copyright © Innovative Technology Ltd. 2016. No part of this publication may be reproduced in any form or by any means used to make any derivative such as translation, transformation or adaptation without permission from Innovative Technology Ltd. The contents of this manual set may be subject to change without prior notice.

1.4 Limited Warranty

Innovative Technology Ltd warrants each of its hardware products to be free from defects in workmanship and materials under normal use and service for a period commencing on the date of purchase from Innovative Technology Ltd or its Authorized Reseller, and extending for the length of time stipulated by Innovative Technology Ltd.

A list of Innovative Technology Ltd offices can be found in every section of this manual set. If the product proves defective within the applicable warranty period, Innovative Technology Ltd will repair or replace the product. Innovative Technology Ltd shall have the sole discretion whether to repair or replace, and any replacement product supplied may be new or reconditioned.

The foregoing warranties and remedies are exclusive and are in lieu of all other warranties, expressed or implied, either in fact or by operation of law, statutory or otherwise, including warranties of merchantability and fitness for a particular purpose.

Innovative Technology Ltd shall not be liable under this warranty if it's testing and examination disclose that the alleged defect in the product does not exist or was caused by the customer's or any third person's misuse, neglect, improper installation or testing, unauthorized attempts to repair, or any other cause beyond the range of the intended use. In no event, will Innovative Technology Ltd be liable for any damages, including loss of profits, cost of cover or other incidental, consequential or



[<< Back to Contents](#)

indirect damages arising out the installation, maintenance, use, performance, failure or interruption of an Innovative Technology Ltd product, however caused.

1.5 Product Safety Information

Throughout this user manual, key safety points to be aware of when using or maintaining the product will be highlighted in a box, like this:

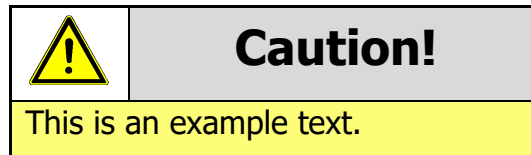

This user manual and the information it contains is only applicable to the model stated on the front cover, and must not be used with any other make or model.

1.6 Disclaimer

Innovative Technology Ltd is not responsible for any loss, harm, or damage caused by the installation and use of this product. This does not affect your local statutory rights. If in doubt please contact Innovative Technology for details of any changes.

Innovative Technology Ltd has a policy of continual product improvement. As a result the products supplied may vary from the specification described here.

Innovative Technology Ltd does not accept liability for any errors or omissions contained within this document. Innovative Technology Ltd shall not incur any penalties arising out of the adherence to, interpretation of, or reliance on, this standard.





Safety Notice! Read before using this product!

Safety Notice - Warning. Ensure power is removed before allowing access to the inside of this product. Ensure any static build up is discharged before allowing access to any part of this product or media contained. Always earth this product/base plate in accordance with the manual.

For use only in or with complete equipment where the acceptability of the combination is determined by UL LLC. When installed in an end-product, consideration must be given to the following:

- The power supply terminals and/or connectors are: Not investigated for field wiring
- The investigated Pollution Degree is: 2
- The following end-product enclosures are required: Mechanical, Fire

Sicherheitshinweis – Warnung: Es muss sichergestellt werden, dass das Gerät von der Versorgungsspannung getrennt wird, bevor ein Eingriff in das Innere des Gerätes erfolgt. Es muss sichergestellt werden, dass jegliche statische Aufladung des Gerätes entladen wird, bevor auf das Gerät oder auf innerhalb des Gerätes befindliche Objekte zugegriffen wird. Die Erdung des Gerätes muss immer gemäß Handbuch erfolgen.

Nur für die Verwendung in oder mit kompletter Ausstattung, dessen Eignung und Kombination von der UL LLC ermittelt wurde. Bei der Installation in einem Endprodukt, muss folgendes berücksichtigt werden:

- Die Spannungsversorgungsklemmen und/oder Verbinder sind: Feldverkabelung wurde nicht untersucht
- Der untersuchte Verschmutzungsgrad ist: 2
- Folgende Anforderungen an die Gehäuse des Endproduktes sind gefordert: Mechanisch, Feuer

Aviso de seguridad: Asegúrese de que la alimentación está desconectada y de que toda la energía estática es descargada antes de manipular este producto. Conecte a tierra la chapa base de la manera que se indica en el manual.

Solo para uso con dispositivos con los cuales la compatibilidad ha sido certificada por UL LLC. Tras su instalación en producto acabado, tener en cuenta lo siguiente:

- Los conectores y terminales de alimentación son: No se ha investigado/especificado cableado externo.
- El grado de contaminación determinado es: 2
- Los siguientes manuales/certificados de producto final son requeridos: Mecánico, Fuego

Avis de sécurité : Assurez-vous que l'alimentation est coupée et que toute l'énergie statique est déchargé avant de manipuler ce produit. Connecter à la terre, la plaque de base à la manière indiquée dans le manuel.

A utiliser Seulement avec les dispositifs dont la compatibilité a été certifiée par UL LLC. Après son installation dans le produit fini, prendre en considération ce qui suit:-

- Les connecteurs et les bornes d'alimentation sont : cela n'a pas été étudié/spécifié câblage externe.
- Le degré de contamination déterminé est: 2
- Les manuels suivants / les certificats du produit final sont nécessaires : mécanique, incendie

Bezpečnostní upozornění. Před manipulací uvnitř tohoto produktu se ujistěte, že je produkt odpojen od zdroje elektrického napětí. Ujistěte se, že jakýkoliv elektrostatický náboj byl vybit před manipulací s jakoukoliv částí tohoto produktu nebo obsaženým médiem. Vždy uzemněte tento produkt/základovou desku v souladu s návodem.

Pouze pro použití v nebo s kompletním vybavením, kde je přijatelnost kombinace určena UL LLC. Při instalaci v konečném produktu je třeba zvážit následující:

- Napájecí svorky a/nebo konektory: Nejsou sledované pro externí kabeláž
- Sledovaný stupeň znečištění je: 2
- Následující krytí konečného produktu jsou požadované: Mechanické, Protipožární



2 PRODUCT INTRODUCTION

2.1 General Description

The NV200 is a high volume, high security banknote validator capable of accepting banknotes up to 85mm wide and 170mm long as well as industry standard bar coded tickets.

With a lockable, removable cashbox or a Tamper Evident cashbox (TEBS) that can hold up to 1000 notes the unit is ideal for global high volume applications.

The modular approach enables additional cash handling capabilities to be added with ease. The SMART Payout allows mixed denomination note recycling while the SMART Ticket enables ticket in /ticket out functionality.

2.2 Key Features

- Exceptional note handling
- Suitable for global applications
- Add on recycler available
- Secure tamper evident cashbag (TEBS System)
- Secure closed loop accounting (TEBS System)
- Eliminates cash shrinkage (TEBS System)
- Unrivalled mixed denomination note recycler (Recycler Module)
- Eliminates coin starvation (Recycler Module)
- Maximises cash efficiency (Recycler & Ticket Module)
- Revolutionary note in / ticket out design (SMART Ticket)
- Fan fold or continuous roll tickets (SMART Ticket)

2.3 Typical Applications

- Gaming
- Amusement
- Vending
- Retail & Kiosk



NV200 Family User Manual

[<< Back to Contents](#)

2.4 Component Overview

NV200 Validator



Cashbox options



Lockable,
Removable 500
note cashbox



Lockable,
Removable 1000
note cashbox



TEBS – Tamper
Evident Bagging
System

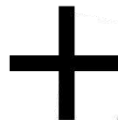

Payout Module –
True Multi-Note
recycling



Ticket Module –
TITO Solution



[<< Back to Contents](#)

2.4.1 Interface connectors

The NV200 validator has two connectors for interfacing and programming; these connectors are easily accessible at the back of the validator.



Information

Power is required regardless of connection type.

Regardless of the connector type being used power is required on pins 15(+V) and 16(0V) of the 16 way connector.

The first connector is a 16-pin Molex 9733272, used to interface the NV200 to the host machine. The pin numbering of the socket is shown below:



When a Payout or Ticket Module is connected a 16-pin Molex 0039012165 connector will replace the 16-pin Molex 9733272, the Pinout is below:



There is also a standard Type 'B' USB socket which can be used for programming the NV200 – a USB 2.0 compliant Type 'A' to 'B' lead can be used to do this.

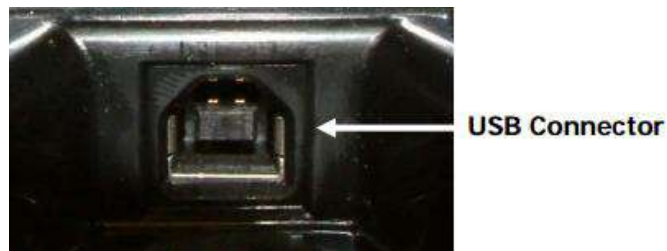

Caution!

The USB connection is not recommended for continuous use only for re-programming or troubleshooting.

The TEBS & Smart Ticket require an additional 4-pin Tyco 794954-4 power connector (CN389).



NV200 Family User Manual

[<< Back to Contents](#)

2.4.2 User Interfaces

2.4.2.1 Dip Switches on the NV200

The NV200 has a Dual Inline Package (DIP) switch bank that is used to set the various options for the unit. A summary of the switch options are shown below:



Switch	Option	Switch OFF (↓)	Switch ON (↑)	Default Setting
1	Disable Barcode	Read enabled	Read disabled	OFF
2	Channel 1 Inhibit	Channel enabled	Channel disabled	OFF
3	Channel 2 Inhibit	Channel enabled	Channel disabled	OFF
4	Channel 3 Inhibit	Channel enabled	Channel disabled	OFF
5	Channel 4 Inhibit	Channel enabled	Channel disabled	OFF
6	Channel 5 Inhibit	Channel enabled	Channel disabled	OFF
7	Channel 6 Inhibit	Channel enabled	Channel disabled	OFF
8	Protocol Select	*Switches between the primary (selected) protocol and SSP (used for Programming). The switch needs to be toggled ON and OFF to alternate between the two. This will cause the unit to reset.		OFF

2.4.2.2 Dip Switches on the Payout module

The SMART Payout unit has a Dual Inline Package (DIP) switch bank that is used to set the various options for the unit. A summary of the switch options are below:

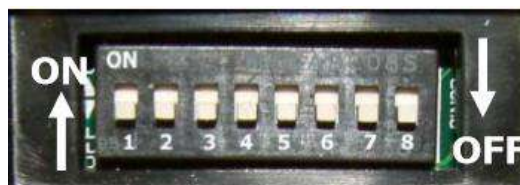

Switch	Option	Default Setting
1-6	Not Used	OFF
7	Prevents the NV200 from updating the payout module	OFF
8	Forces the diverter to close (unit must be powered)	OFF

2.4.2.3 Smart Ticket Button

The SMART Ticket Has a button on the rear of the unit.





Pressing and holding this button will lead to a test ticket being printed, this ticket will show information on Firmware and the current printer settings.

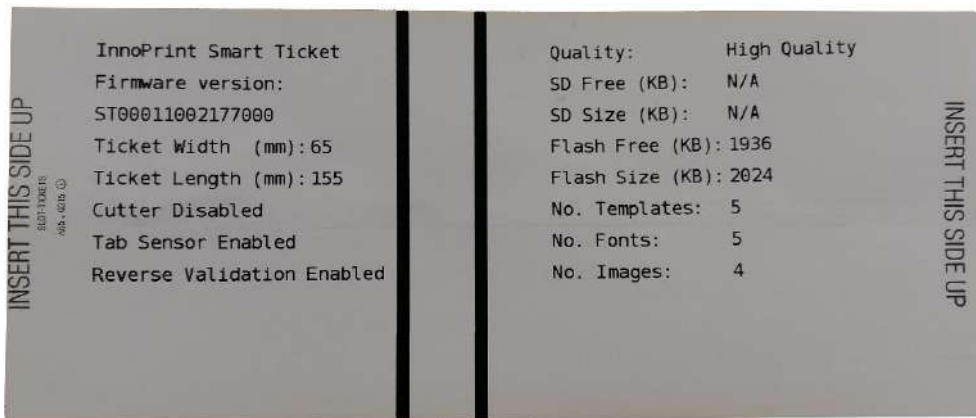

2.4.2.4 Smart Ticket Dip Switches

The SMART Ticket has 4 Dipswitches in the unit, these switches can be found by opening the Ticket path.

To open the ticket path, squeeze the clips on the top of the SMART Ticket and lift the lid.

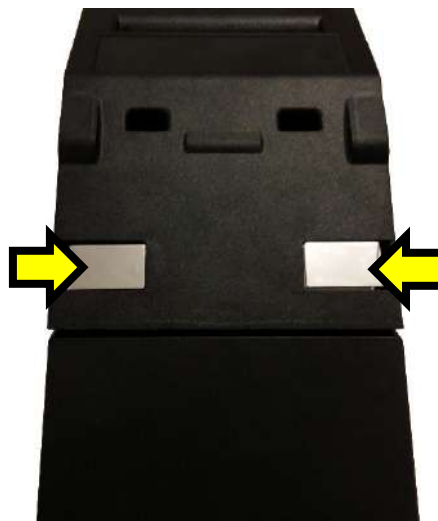

Once there is a dock of 4 dipswitches at the hinge of the SMART Ticket on the Right Side.

NV200 Family User Manual

[<< Back to Contents](#)



Switch	Option	Default Setting
1-3	Not used	OFF
4	"Safe Mode" – stops the Printer from Printing any more tickets if the Paper Low Sensor is Triggered.	OFF



NV200 Family User Manual

[<< Back to Contents](#)

2.4.3 Bezel Options

ITL Part Number	Description	Details
PA00610	Standard Bezel	http://innovative-technology.com/shop/bezels/NV200-standard-bezel-detail
PA00634	82mm Bezel	http://innovative-technology.com/shop/bezels/NV200-82mm-width-bezel-detail
PA00639	Metal Bezel	http://innovative-technology.com/shop/bezels/NV200-metal-bezel-detail
PA01038	Self-Aligning Bezel	http://innovative-technology.com/shop/bezels/NV200-self-aligning-bezel-white-detail

2.4.4 Cashbox Options

ITL Part Number	Description	Details
PA00640	NV200 Outer Cashbox Chassis	http://innovative-technology.com/shop/bezels/NV200-outer-cashbox-chassis-detail
PA00629	500n Inner cashbox	http://innovative-technology.com/shop/bezels/NV200-inner-cashbox-detail
PA00635	1000n Inner cashbox	http://innovative-technology.com/shop/bezels/NV200-1000-note-inner-cashbox-detail
PA02198	Tamper Evident Bag System (TEBS)	http://innovative-technology.com/products/products-main/356-tebs

2.4.5 Module Options

ITL Part Number	Description	Details
PA02783	Payout Module	http://www.innovative-technology.com/it/shop-it/bank-note-validators/payout-module-only-detail
PA1062	Ticket Roll Top	http://innovative-technology.com/shop/bank-note-validators/roll-top-ticket-module-detail
PA02060	Ticket Roll Bottom	http://innovative-technology.com/shop/bank-note-validators/roll-rear-ticket-module-detail
PA02074	Ticket Fan Fold Top	http://innovative-technology.com/shop/bank-note-validators/fan-fold-top-ticket-module-only-detail
PA01063	Ticket Fan Fold Bottom	http://innovative-technology.com/shop/bank-note-validators/fan-fold-rear-ticket-module-only-detail

2.4.6 Consumables

ITL Part Number	Description	Details
PA02196	TEBS Safe Bag Box of 140	http://innovative-technology.com/products/products-main/356-tebs
LB02012	Roll Tickets Box of 12	http://innovative-technology.com/shop/printer-spares/smart-ticket-roll-paper-single-box-detail
LB02013	Fan Fold Tickets Box of 20	http://innovative-technology.com/shop/printer-spares/fan-fold-tickets-single-box-detail



NV200 Family User Manual

[<< Back to Contents](#)

3 TECHNICAL DATA

3.1 Dimensions

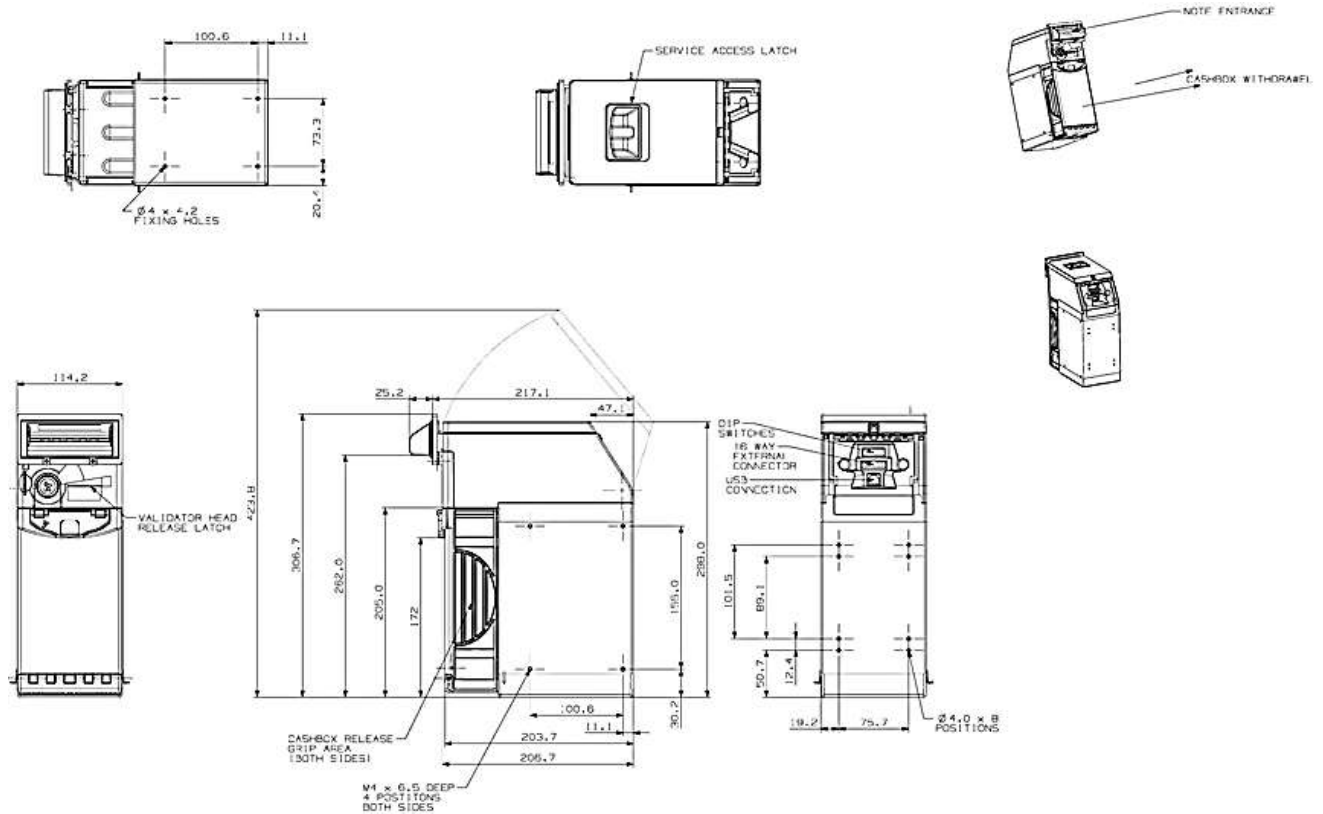

Drawings of all configurations for the NV200 can be found in [Appendix 10.1](#).

3D drawings in .stp form are also available upon request from our support team.

3.2 Weight

NV200 with Standard Bezel 1.1 kg

Cashbox Options

500n with Chassis	Empty: 1.76kg	Full: 2.21kg
1000n with Chassis	Empty: 1.94kg	Full: 2.84kg
TEBS Cashbox	Empty: 6.7kg	Full: 7.5kg

Modules

Payout Module	Empty: 2.54kg	Full: 2.6kg
Ticket Module:	Empty: 1.34kg	Full: 2.64kg

The 'full weight' was taken with a random sample of street grade GBP notes

3.3 Environmental Requirements

Environment	Minimum	Maximum	Maximum Change per Hour
Temperature	+5°C / 37.4°F	+50°C / 122°F	1° per hour
Humidity	5%	95% Non-condensing	2% per hour



NV200 Family User Manual

[<< Back to Contents](#)

3.4 Power Requirements

3.4.1 Supply Voltages

Supply Voltage	Minimum	Nominal	Maximum
Supply Voltage (V DC)	+10.8vDC / +22.6vDC	+ 12vDC / +24vDC*	+14.2 vDC / +26.4vDC
Supply Ripple Voltage	0 V	0 V	0.25 V @ 100 Hz

The TEBS cashbox and Ticket module require the unit is run at 24v ($\pm 10\%$).

3.4.2 Supply Currents

The supply current required to run the NV200 will vary during the phases of operation. Below is a table detailing the required current information.

Phase of operation	Current Draw (A)
Standby	400mA
Running	1.5A
Peak	3A

To use the extra modules such as the payout or ticket module additional power is required. The table below explains the additional current draw required.

Phase of operation	Additional Current Draw TEBS (A)	Additional Current Draw Payout (A)	Additional Current Draw Ticket (A)
Standby	200mA	-	-
Running	-	1.5A	1A
Peak	2.6A	2A	5A*

*Maximum current required to print a solid black ticket

For a NV200 with a TEBS cashbox and payout module, the peak current draw would be:

$$3A + 2.6A + 2A = 7.6A$$

For more detailed power information energy profiles for the various stages of operation can be found in [Appendix 10.2](#).

3.4.3 Power Supply Guidance

Please check the power requirements of your host machine and other peripherals to dimension a suitable power environment for your machine setup.

TDK Lambda manufactures suitable power supplies for the NV200. Please see table below for further details.

Power Supply Unit	Specification	RS Stock Code	Farnell Stock Code	Suitable for use with
TDK Lambda SWS50-12	+12 V DC / 4.3 A	466-5869	1184645	NV200 standalone
TDK Lambda SWS75-12	+12 V DC / 6.3 A	466-5904	1184648	NV200 with Payout module
TDK Lambda SWS150-24	+24 V DC / 6.3 A	466-5982	1184653	NV200 with TEBS or Payout Module
TDK Lambda SWS300-24	+24 V DC / 13.0 A	494-4651	1085928	NV200 with TEBS and Payout/Ticket Module



3.5 Interface Logic Levels

Interface Logic Levels	Logic Low	Logic High
Inputs	0V to +0.5V	+3.7V to +12V
Outputs with 2K2Ω pull-up resistor	+0.6V	Pull-up voltage of host interface
Maximum Current Sink	50mA per Output	

3.5.1 Opto-Isolated Inputs

The NV200 natively supports Opto-isolated communication, the connection requires a reciprocal circuit to be established on the host side. The pin outs for the opto-isolated inputs can be found in [section 5.2.2](#).

3.6 Reliability Data

Below is an explanation outlining the Mean Cycles Between Failure (MCBF) & Mean Cycles Between Interruption (MCBI) for the NV200 family of products. Where a cycle is defined as a note/ticket either stacked, stored or paid-out. An example is if £20 is accepted and a £10 paid out that would be classed as 2 cycles.

The difference between MCBF and MCBI is that a failure is classed as an event which will require a service call – e.g. unit is seeing poor acceptance. Whereas an interruption is an event which store/site staff could rectify without a trained engineer present – e.g. clearing a note path jam.

As explained in [section 2.4](#) the NV200 is a modular solution and these modules increase the complexity of the system. As such each time, one of these additional modules are attached the current MCBF and MCBI is halved.

MCBF data is available upon request from ITL.

3.7 Media Requirements

The NV200 is capable of handling multiple denominations simultaneously, the media that can be accepted includes but is not limited to:

- Polymer notes
- Windowed notes
- Barcoded tickets

The minimum and maximum dimension for media IN is as follows:

	Min	Max
Length:	110mm	170mm
Width:	56mm	85mm

When using the optional smart payout module the media dimensions are as follows:

	Min	Max
Length:	110mm	170mm
Width:	56mm	82mm

When using the optional smart ticket module, the paper requirements are as follows:

	Min	Max
--	-----	-----



Fan Fold		
Length:		160mm
Width:	62mm	65mm
Roll		
Width:		80mm
General		
Thickness:	100µm	120µm
Perforation Strength:	0.7kg	1.3kg

3.8 Compliances and Approvals

3.8.1 EC Declaration of Conformity

The NV200 family is fully compliant with major standards including but not limited to:

- UL
- RoHS
- CE
- Weee
- REACH

3.8.2 Central Bank Approval

As part of continual product improvement central banks are regularly visited to gain product certification. This includes but is not limited to the following ECB, BoE & FED.

Any change in approval status is outlined in our tech bulletins a link to which can be found below:

<http://innovative-technology.com/support/technical-bulletins>



4 MECHANICAL INSTALLATION

4.1 Compatibility

4.1.1 Hardware Compatibility

4.1.1.1 Machine Mounting

The NV200 is not retro-fittable in place of any older Innovative Technology validator however it's footprint is comparable to other high end casino validators, some re-work may still be required to use the NV200 in place of a different validator.

4.1.1.2 Machine Interfacing

By design the NV200 family is pin to pin across the range, should there be any questions regarding the pin-outs see [section 2.4.1](#). If integrating different modules, a change in the harnessing may be required, details of recommended harness configurations can be found in [section 5.2.3](#).

4.1.1.3 Power Supply

As outlined above in [Section 3.4](#) it is vital that the NV200 is connected to a power supply capable of meeting the current requirements as an underpowered PSU can cause events such as note rejects or missing credits. If the NV200 is used as a fitting replacement for an older product its recommended to test the power supply ensuring it meets the requirements of the NV200; please bear in mind the aging of the capacitors in the power supply could affect it's ability to supply peak current loads. Refer to [Section 7.4](#) for full power requirement details.

	Caution!
An insufficient power supply can cause erratic performance!	

4.1.2 Software Compatibility

4.1.2.1 Interface Protocols

When using the NV200 as a fitting replacement for an older model or product some events such like credits may be given at a different time, due to modified firmware routines. This may cause missing events such like credits in certain host machines where timeouts are tightly defined for the older model or product. Please contact the machine manufacturer for full compatibility.

	Caution!
Timing issues may cause missing events!	

4.1.2.2 Re-programming

For re-programming the NV200 always use the latest version of Validator Manager which is available for download on our website. Older versions may not fully support the NV200. For further details on Re-programming the NV200 refer to [6.3](#).

	Caution!
Older versions of Validator Manager may not completely support the NV200!	

[<< Back to Contents](#)

4.2 Bezel Mounting

4.2.1 Bezel Fitting



WARNING!

Ensure bezel is secured to validator

The bezel should be secured to the validator head using screws if the NV200 is being installed and transported inside a host machine.



Information

Check bezel fixing screw length before installation.

The length of the bezel fixing M4 screws must be no more than 12 mm in length.

The bezel is designed to be removed and refitted easily. To remove or refit the bezel, access to the note path is required – the top cover must be open fully to allow access to the bezel mounting area.

1

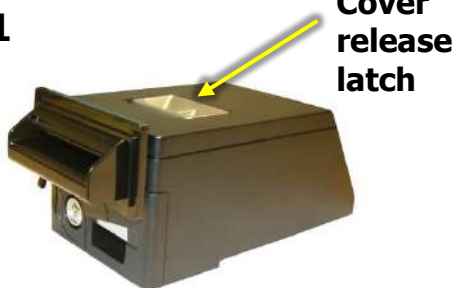

Validator note path cover

2

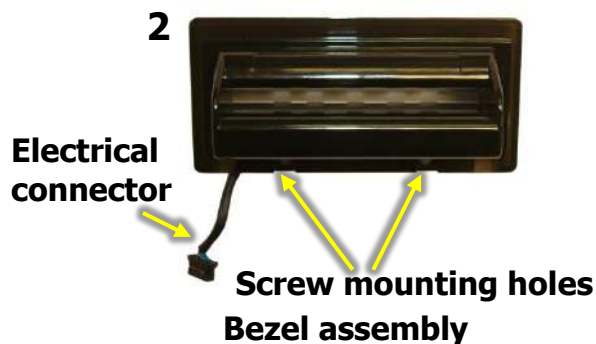

3



Bezel connector socket

4

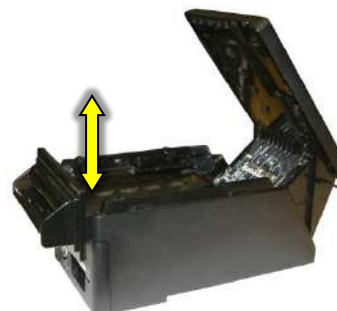

Bezel removal and fitting

Fitting the bezel: Lift the upper cover by pulling the latch forward as shown in picture 1. Connect the cable from the bezel assembly (as shown in picture 2) to the socket located on the front of the validator head (as shown in picture 3) and slide the assembly down into place and close the note path upper cover (as shown in picture 4). If required, the bezel can be secured in place with two M3 screws - these are fitted in the two holes at the bottom of the bezel.

When fitting the bezel please ensure the NV200 is removed from the cashbox to prevent any issues with fitting.



[<< Back to Contents](#)

4.3 Cashbox Removal

4.3.1 Standard Cashbox Removal

To remove the cashbox, pull the handle away from the unit, this will unlatch the cashbox before allowing them to slide out.

The NV200 may have to be unlocked before removing the cashbox.

500n Cashbox:

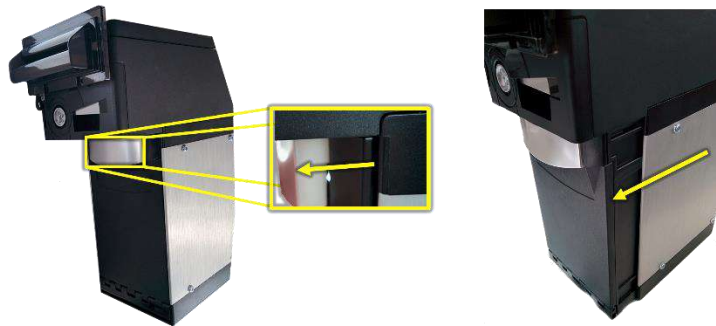

1000n Cashbox:

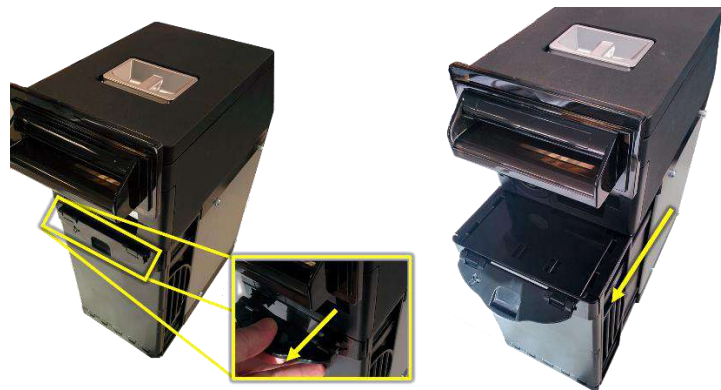

When the cashbox has been removed to access the money, turn it upside down and open the flap as shown in the picture to the right.

There may be a further CAM lock at the bottom of the cashbox.



4.3.2 TEBS Cash Bag Removal & Replacement

Unlike the traditional cashbox, the TEBS has both a software and hardware lock. Before the cashbox can be removed the software, lock must have been enabled (when enabled the lock is green).

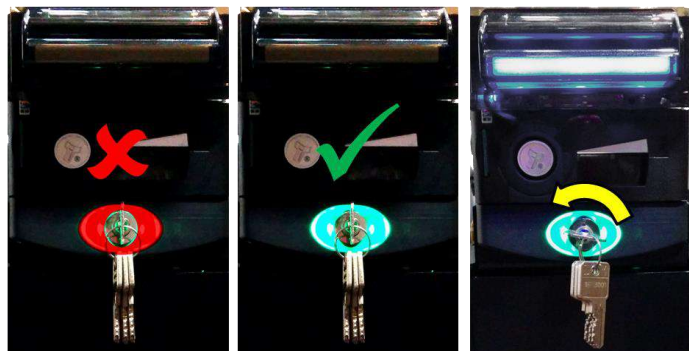

Once the key has been turned the bezel will begin to flash the cashbox can be removed as shown on the right.



To remove the cashbox, slide the catch to the side and lift the cash bag out of the cashbox. As shown to the right.

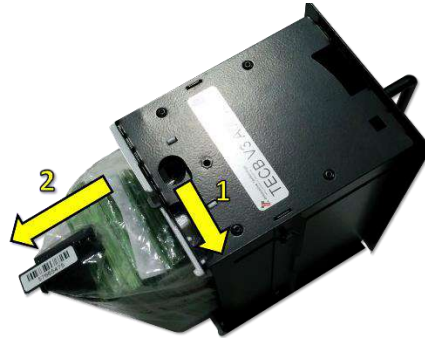

To fit the cash bag insert the bottom lug, slide the latch to the side and push the bag into place. Ensuring the barcode is sat in place.



Slide the cash bag back into the TEBS and turn the lock – the lock will go red. The stacker will audibly cycle and the bezel flash code will disable showing the barcode has been read.

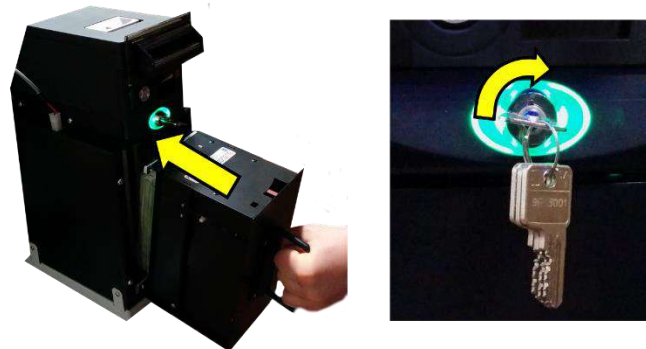

4.4 Loading paper into the Smart Ticket

The methods for loading paper into the various SMART Ticket configurations are shown below.

The sections are separated into Ticket Type; roll or fan fold, and loading position; Top or Rear.

4.4.1 Roll

4.4.1.1 Top

The Roll paper is mounted orientated such that the paper edge goes straight from the roll into the Printer, as shown in the picture below.



[<< Back to Contents](#)

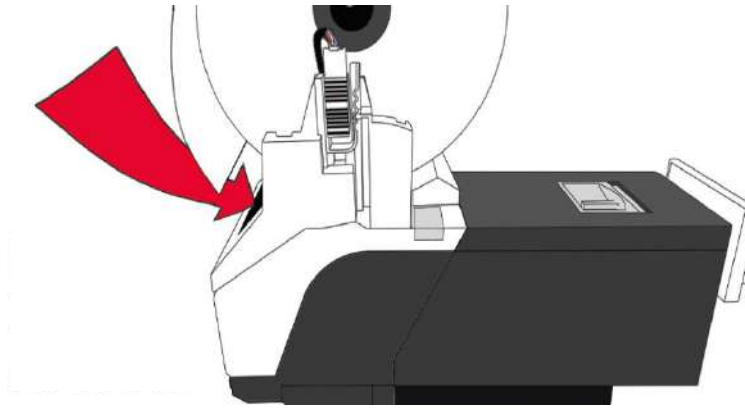

4.4.1.2 Rear

The Roll is inserted into the Rear holder with the paper wrapping round the underside of the printer, before passing underneath the metal positioning arm and into the printer, as shown in the pictures below.

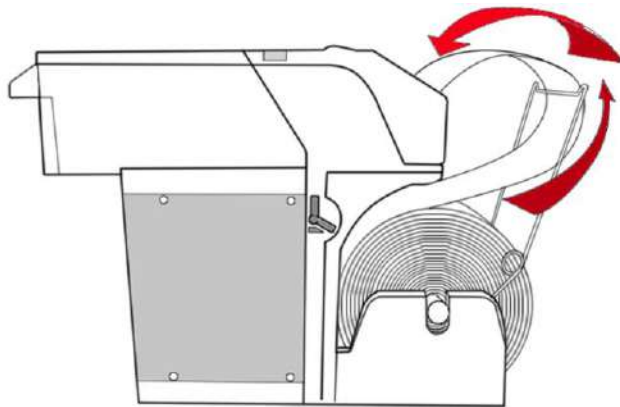

4.4.2 Fan Fold

The Fan Fold Tickets Has TABS printed onto the Ticket that must be used to determine the correct orientation of the Ticket, the image below shows the TABS.

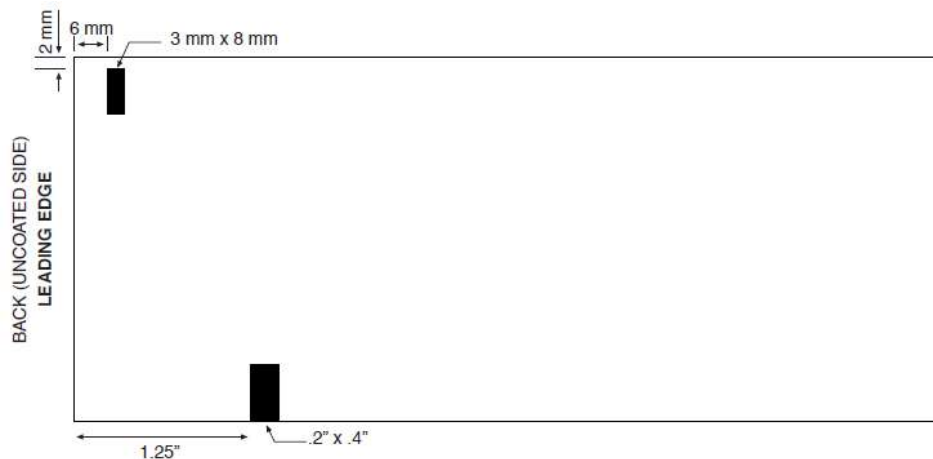

4.4.2.1 Top

The Fan Fold Tickets are inserted into the printer with the TABS on the leading edge.





When the paper is inserted into the printer, the TABS need to face towards the NV200.

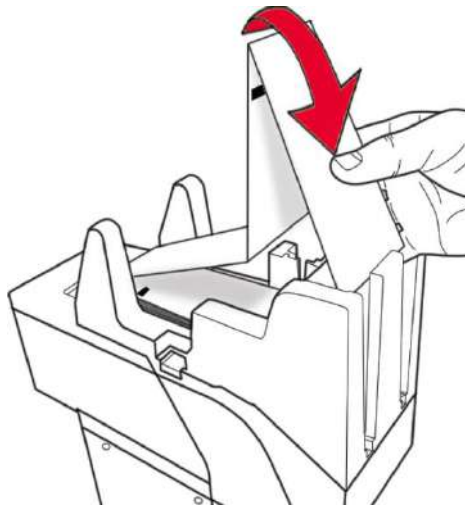

4.4.2.2 Rear

Tickets are loaded with the paper edge and TABS going towards the Printer.

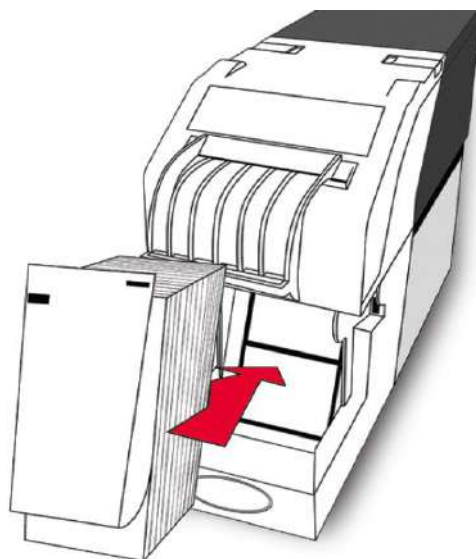

The ticket is then fed into the ticket guide.

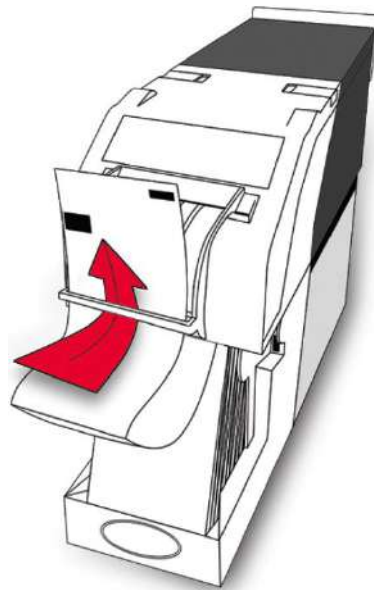

Before being inserted into the printer with the TABS facing towards the NV200.

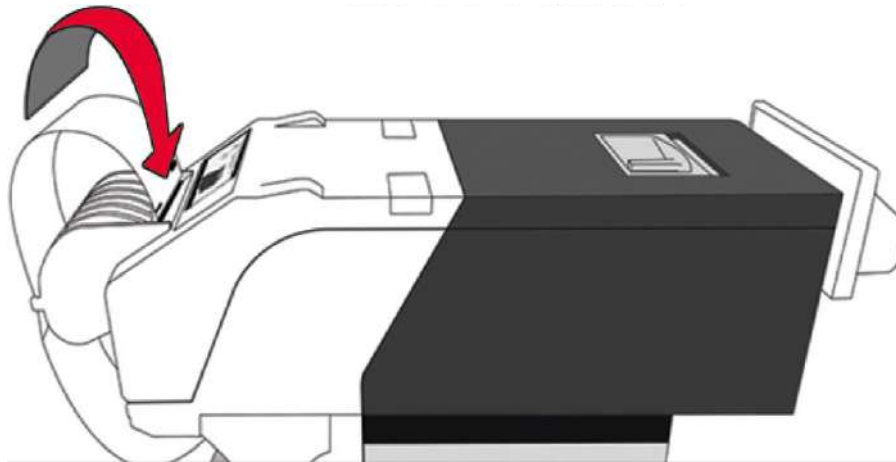

4.5 Lock Mounting

4.5.1 Lock Fitting – NV200

The Lock can be fitted to the front of the NV200 replacing the silver front plate (shown to the right) which ships by default.



Before the lock can be installed, remove the NV200 from the cashbox chassis. Lift the latch, slide the head forward and lift the head away from the chassis.

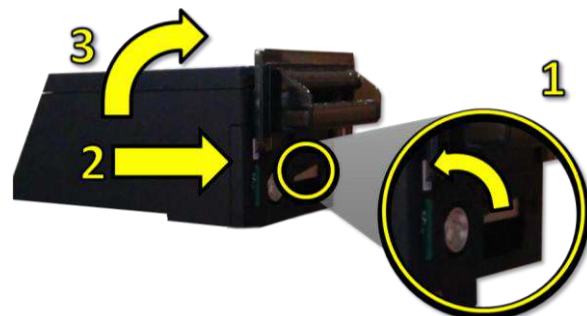

NV200 Family User Manual

[<< Back to Contents](#)

There are 2xT8 screws located on the underside of the NV200, remove those and lift away the plastic insert.

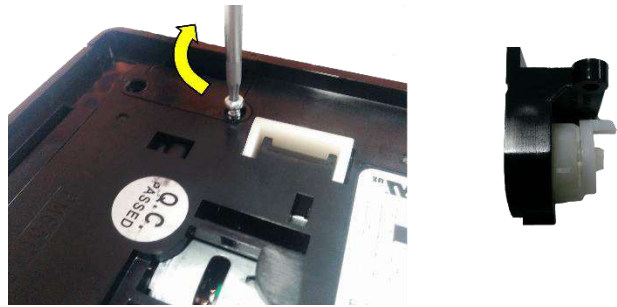

Press the plastic clip together and remove the locking cam.



To remove the plastic insert, from the lock mount, press the two clips on the side together and push through. Insert the cam lock in its place.



Re-attach the locking cam onto the barrel of the lock and tighten.



To fit the assembled lock into the unit place the bottom in first the push the top into position.

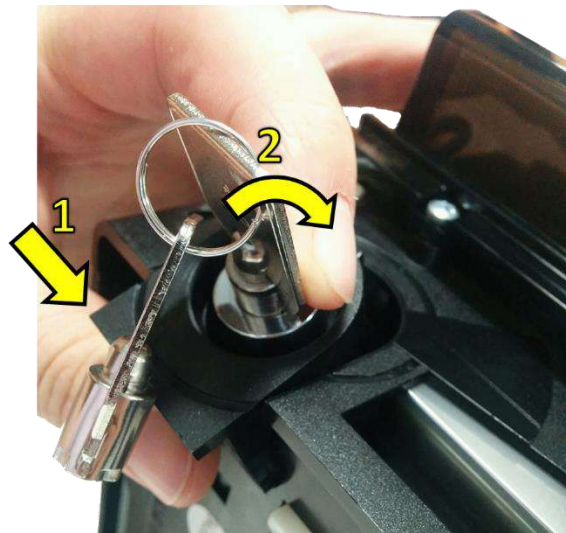

Turn the unit upside down and screw in the 2xT8 screws previously removed.

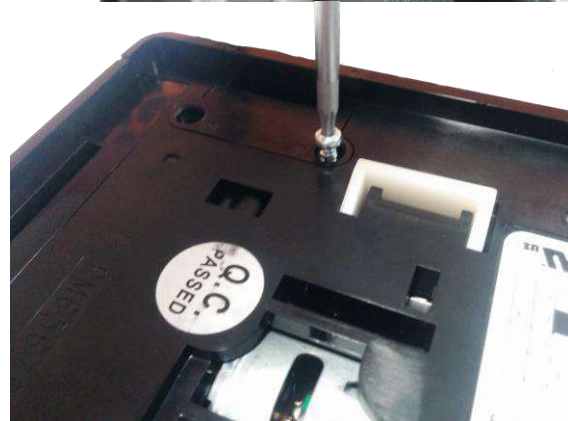

4.5.2 Lock fitting – Standard Cashbox

The standard NV200 cashbox can be fitted with 2 locks for security. These are located on the bottom of the cashbox on the hinged door.



Similarly, to fitting a lock on the front of the NV200 remove the locking cam and blanking plate which is there by default and replace with the desired lock.



[<< Back to Contents](#)

With the lock in place add the washer and the locking cam.

Ensure when the keylock is turned the locking cam is inserted in the same position it was previously removed otherwise it can cause interference.



4.5.3 Lock Fitting - TEBS Cashbox

The TEBS comes installed with a lock from the factory. The standard lock fitting for the TEBS cashbox is PA02540.

4.5.4 Lock Specifications

Locks for the NV200 are available from Innovative Technology Ltd.

ITL Part Number: PA00650

Webshop Link: <http://innovative-technology.com/shop/NV200-spares/lock-detail>

There are various lock manufacturers and distributors. Refer to [Appendix 10.3](#) for lock specification.

4.5.5 Lock Cam

The following Lock Cam needs to be ordered from Innovative Technology Ltd. additionally to the lock for full locking capability.

NV200 Lock Cam Part Number: PM00614

Webshop Link: <http://innovative-technology.com/shop/NV200-spares/NV200-latch-and-base-assembly-detail>

Cashbox Lock Cam Part Number:

Webshop Link: <http://innovative-technology.com/shop/NV200-spares/NV200-cashbox-lock-cam-detail>

4.6 Machine Mounting

The NV200 family can be mounted in a range of different methods as described in [Appendix 10.1](#); when changing between the standard cashboxes and TEBS cashbox the change in dimensions will need to be accounted for. The mounting points for both cashboxes can be seen below:



NV200 Family User Manual

[<< Back to Contents](#)

4.6.1 Machine Mounting - Standard Cashbox

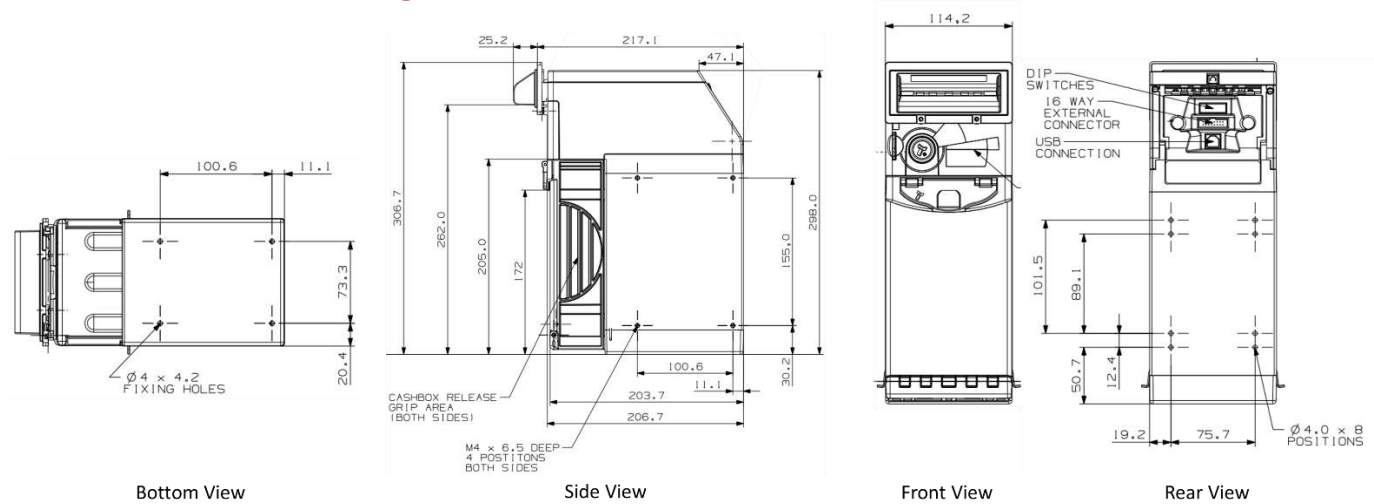

A larger version of this drawing can be found in [Appendix 10.1](#).

4.6.2 Machine Mounting – TEBS

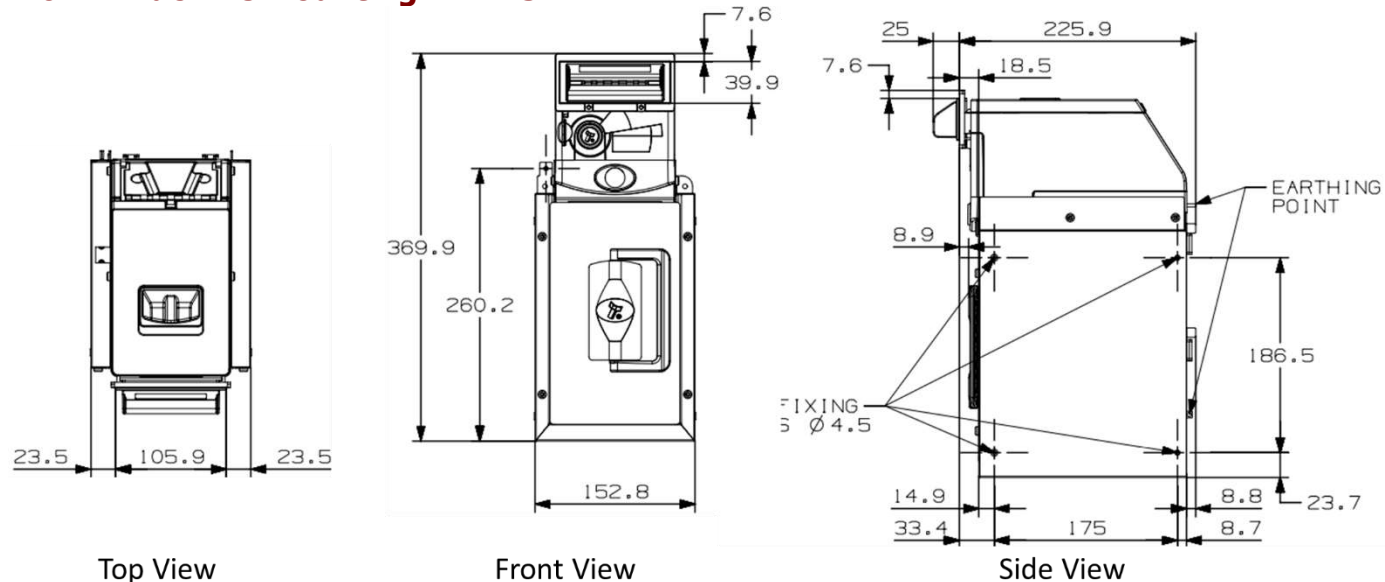

A larger version of this drawing can be found in [Appendix 10.1](#).

4.6.3 Things to consider

When mounting an NV200 there are several things to consider including:

- Smart ticket – minimum distance surrounding machine, details of which can be found in [Appendix Error! Reference source not found.](#) along with larger versions of the NV200 and TEBS drawings.
- Weight of a fully loaded unit as defined in [Section 3.4](#).
- Accessibility – ensure it is possible to reach all connectors and switches if required.
- Cable management – to ensure no connectors are damaged/removed from everyday use.

4.6.4 Earth Bonding

It is very important that the product is properly bonded to earth, using one of the earth tabs. Earthing on the standard chassis can be affixed to any of the screw mounting points at the side of the unit. Whereas with the TEBS cashbox there are earthing points at the back of the chassis as shown below:





Lack of proper bonding can cause communication issues and other failures. The resistance between the chassis and Earth should be less than 0.7Ω.

	Caution!
Lack of proper earth bonding causes failures!	

4.6.5 Screw Specifications

The scope of delivery does not include screws for machine mounting. See table below for screw specification reference.

Location	Thread Type	Screw Length
TEBS Cashbox	M4	16mm
NV200 Bezel	M3	12mm
NV200 Cashbox	M4	6mm

5 PROTOCOLS AND INTERFACING

5.1 Introduction

The NV200 supports standard industry protocols. Interfaces that are not listed may be available upon request. For any queries regarding interfaces that are not listed please contact support@innovative-technology.com.

	Caution!
The use of an encrypted protocol (preferable eSSP) is strongly recommended to achieve the highest security!	

5.2 SSP

5.2.1 General Description

Smiley® Secure Protocol (SSP) is a field proven secure interface specifically designed by Innovative Technology Ltd. to address the problems by cash handling systems in gaming machines. Problems such as acceptor swapping, re-programming and line tapping are all addressed. This interface is recommended for all new designs. Innovative Technology Ltd. provides full SDK packages upon request including Interface Specification, Implementation Guide as well as source code examples.

5.2.2 Pin Assignments

Whilst the optional modules for the NV200 use a clipping 16-pin connector in place of the standard NV200 connector the pin outs are largely the same, please see below:



NV200 Connector

Payout Connector

Ticket Connector

NV200 Family User Manual

[<< Back to Contents](#)

Pin	Name	Type	Description
1	Tx	Output	Serial Data Out (Tx)
4	Tx to Printer	Output	Serial Data Out (Tx) – PRINTER ONLY
5	Rx	Input	Serial Data In (Rx)
8	Rx to Printer	Input	Serial Data In (Rx) – PRINTER ONLY
15	+ Vin	Power	+12/24VDC Supply
16	0V	Power	0V Supply (GND)

5.2.3 Setup Examples

5.2.3.1 NV200

The drawing below highlights how to connect the NV200 to an SSP host machine using available cables and interfaces from Innovative Technology Ltd. For cable drawings please refer to [Appendix 10.4](#).

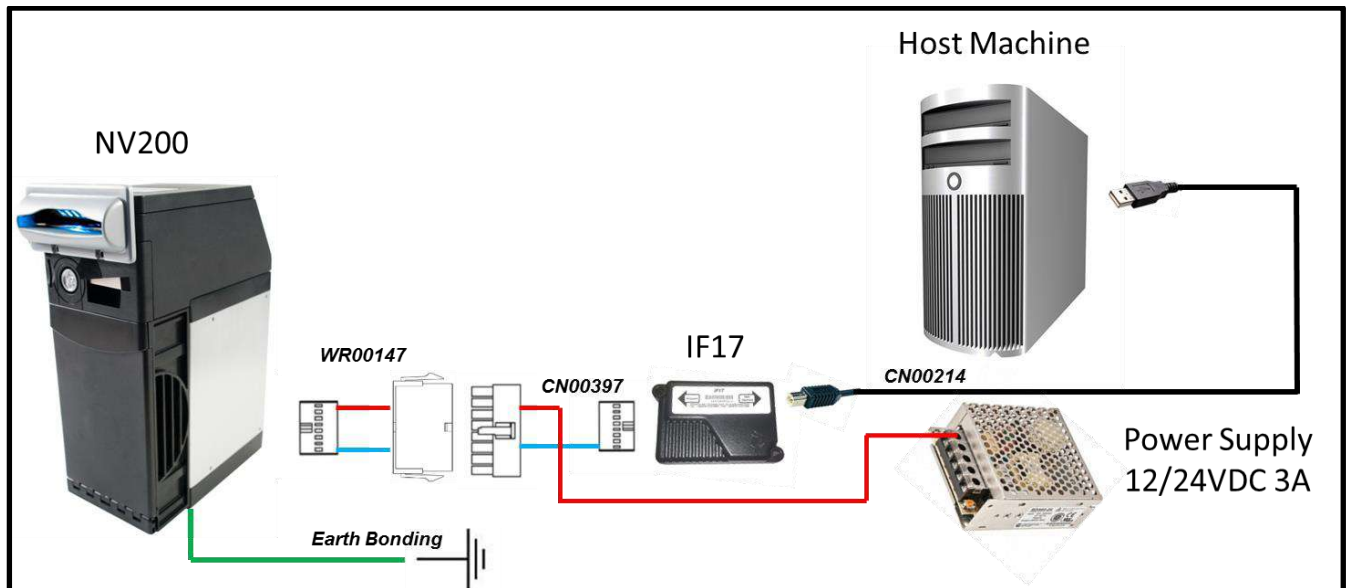

5.2.3.2 NV200 – TEBS Cashbox

The drawing below highlights how to connect the NV200 TEBS to an SSP host machine using available cables and interfaces from Innovative Technology Ltd. For cable drawings please refer to [Appendix 10.4](#).



NV200 Family User Manual

[<< Back to Contents](#)

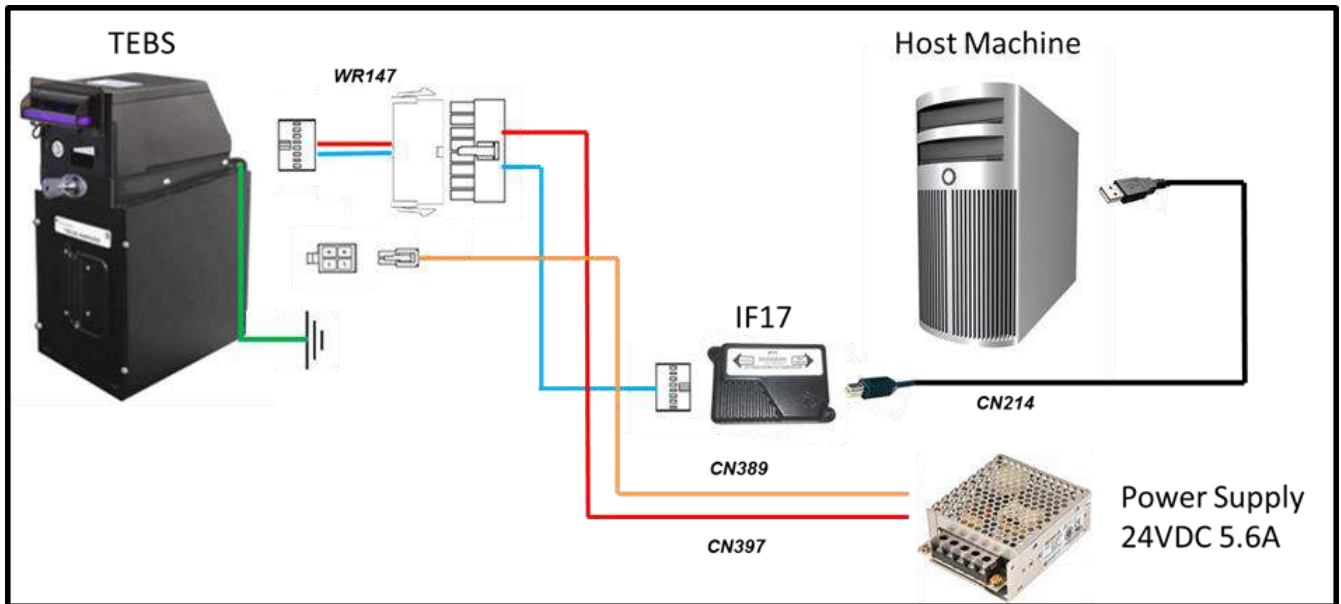

5.2.3.3 NV200 with Payout Module (SPO)

The drawing below highlights how to connect the SPO to an SSP host machine using available cables and interfaces from Innovative Technology Ltd. For cable drawings please refer to [Appendix 10.4](#).

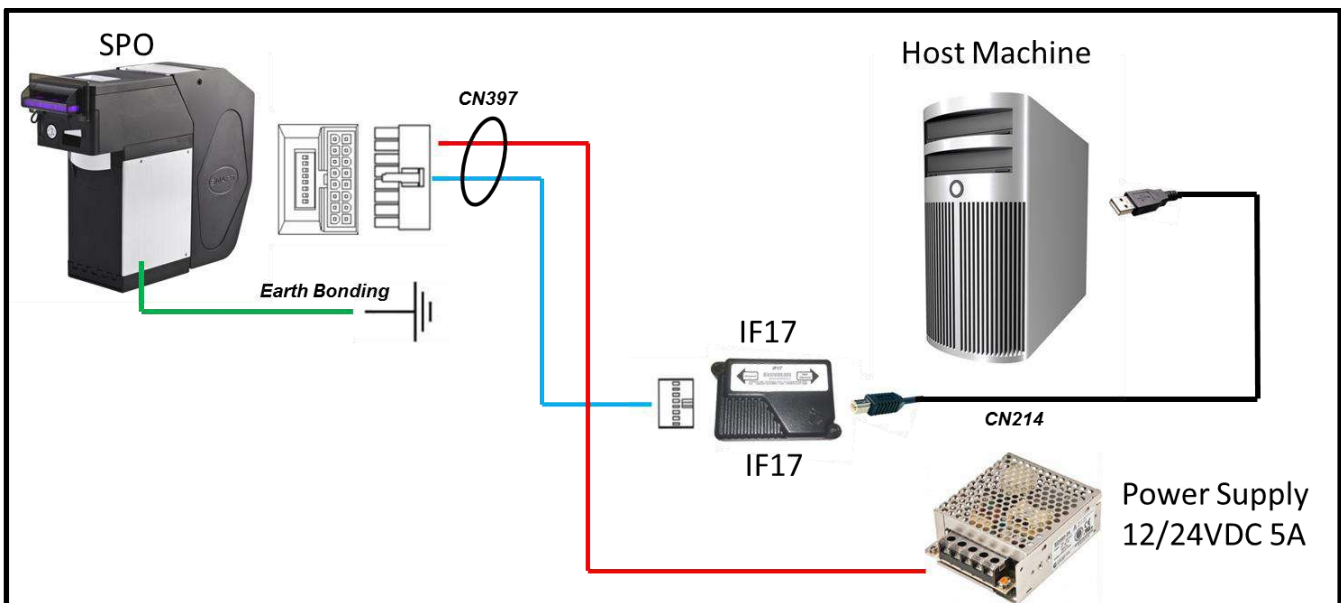

NV200 Family User Manual

[<< Back to Contents](#)

5.2.3.4 NV200 TEBS with Payout Module (TEBS SPO)

The drawing below highlights how to connect the TEBS SPO to an SSP host machine using available cables and interfaces from Innovative Technology Ltd. For cable drawings please refer to [Appendix 10.4](#).

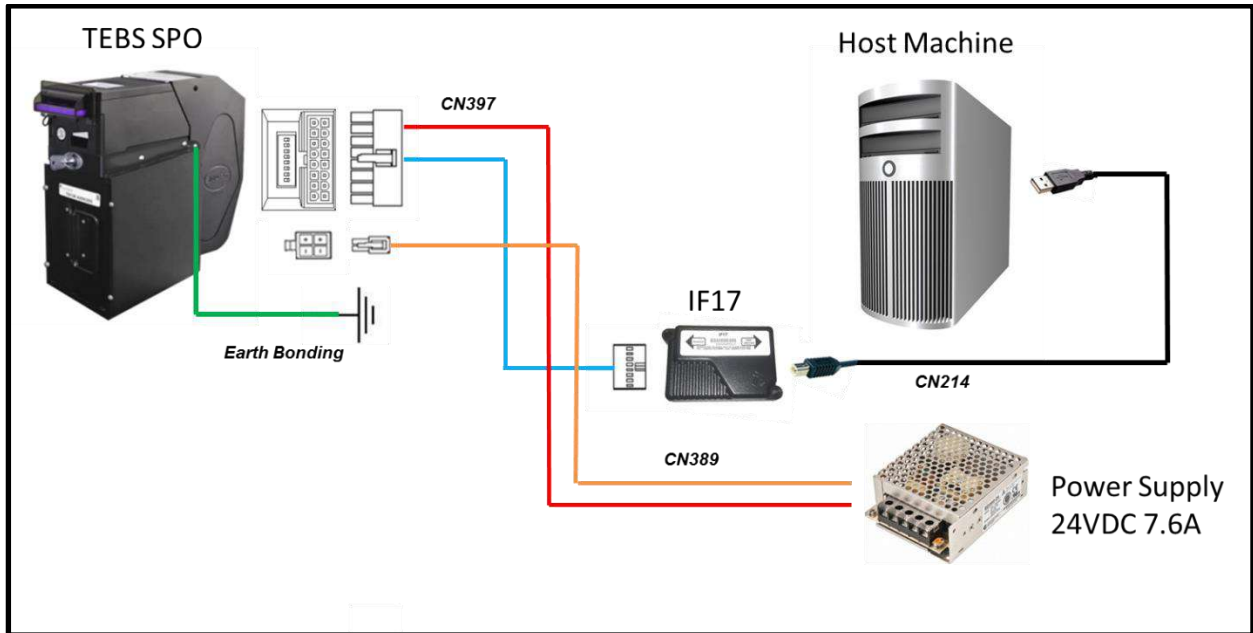

5.2.3.5 NV200 with Ticket Module (SMART Ticket)

The drawing below highlights how to connect the SMART Ticket to an SSP host machine using available cables and interfaces from Innovative Technology Ltd. For cable drawings please refer to [Appendix 10.4](#).

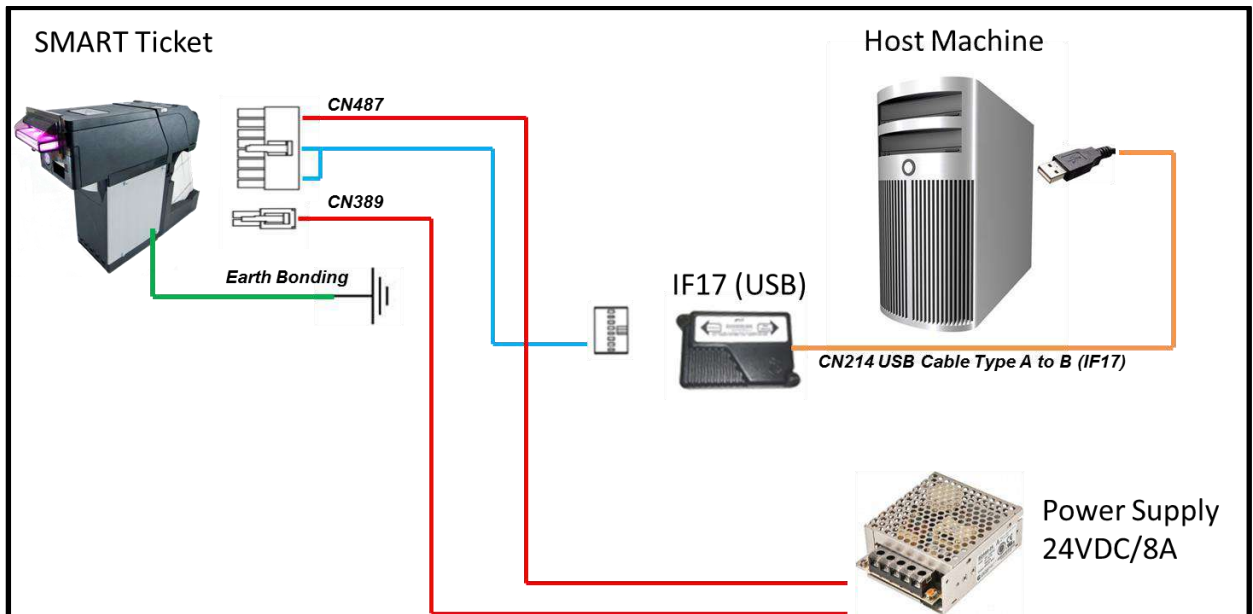

NV200 Family User Manual

[<< Back to Contents](#)

5.2.3.6 NV200 TEBS with Ticket Module (TEBS SMART Ticket)

The drawing below highlights how to connect the TEBS SMART Ticket to an SSP host machine using available cables and interfaces from Innovative Technology Ltd. For cable drawings please refer to [Appendix 10.4](#).

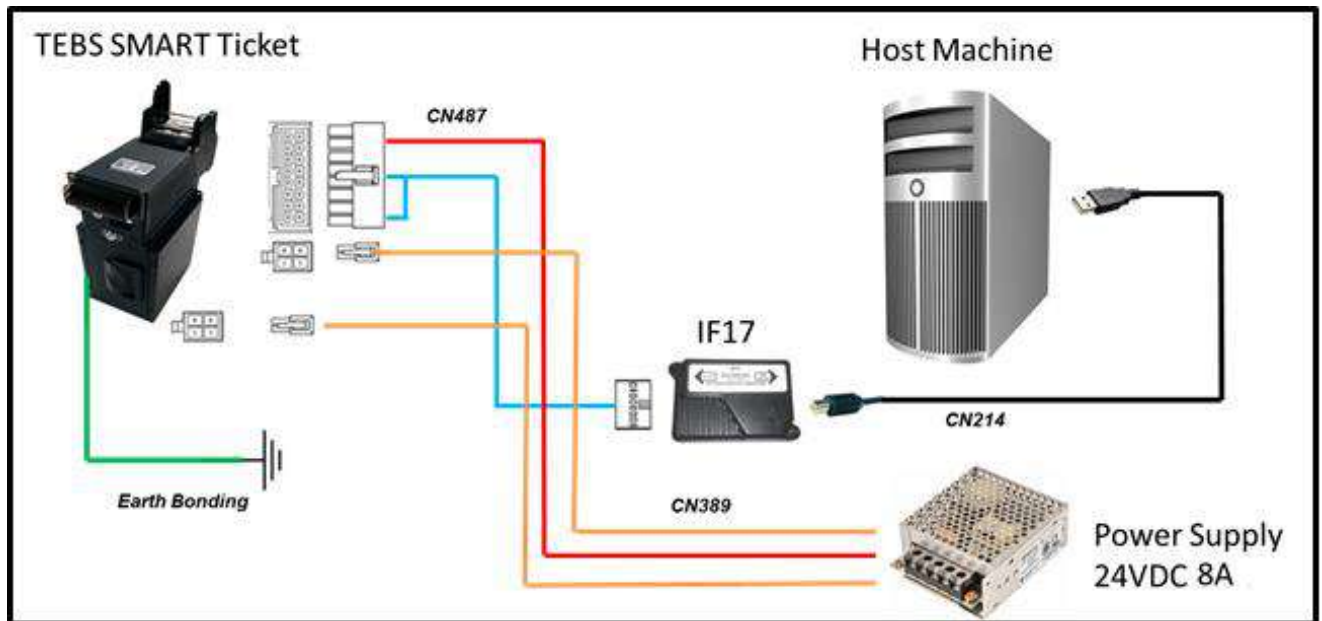

5.3 ccTalk®

5.3.1 General Description

ccTalk® is a serial communications protocol designed to allow 3-wire interfacing between a host and cash handling peripherals.

From the NV200 family only the NV200 with standard cashbox and Payout module are compatible capable of communicating via ccTalk. The TEBS cashbox and Ticket module are currently only implemented in SSP.

5.3.2 Pin Assignments

The connectors for the NV200 can be seen below:

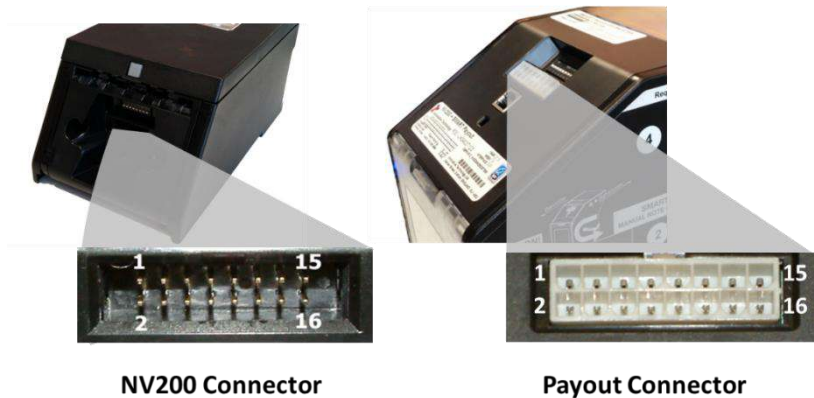

Pin	Name	Type	Description
1	TTL Transmit (Tx)	Output	Serial Data (optionally link to Pin 5*)
5	TTL Receive (Rx)	Input	Serial Data (optionally link to Pin 1*)
15	+ Vin	Power	+12/24VDC Supply
16	0V	Power	0V Supply (GND)

**If true ccTalk communication is required.*

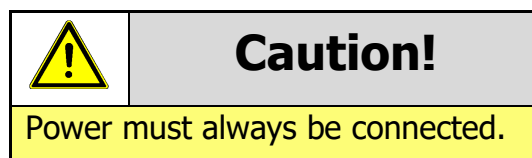

5.3.3 ccTalk® DES Encryption

When using ccTalk® DES encryption, the NV200 and host machine must exchange a secret key which forms the basis of the communication encryption. This exchange is performed in a Trusted Mode maintaining security. The Trusted Mode can only be entered by a physical access to the unit. Please refer to [Appendix 10.8](#) for details.

5.3.4 ITL Specific Implementations

5.3.4.1 CC1

CC1 is a multi-hopper emulation version of ccTalk, this allows the NV200 with Payout Module to appear as a separate unit for each denomination within the dataset. As such it will respond to a range of address as opposed to one. Typically, this is used when retrofitting the NV200 into units with multiple single coin hoppers.

5.3.4.2 CC2

CC2 is developed by Innovative Technology to add multi-note recycling to ccTalk machines, details of the extra commands can be found in GA863, the latest version can be obtained from the link in [Section 1.1](#).

NV200 Family User Manual

[<< Back to Contents](#)

5.3.5 Setup Example Drawing/s

5.3.5.1 NV200

The drawing below highlights how to connect the NV200 to a ccTalk host machine using available cables and interfaces from Innovative Technology Ltd.

This is not true ccTalk as the Tx and Rx pins are not joined, pin 1 and 5 can be connected if required.

For complete cable drawings please refer to [Appendix 10.4](#).

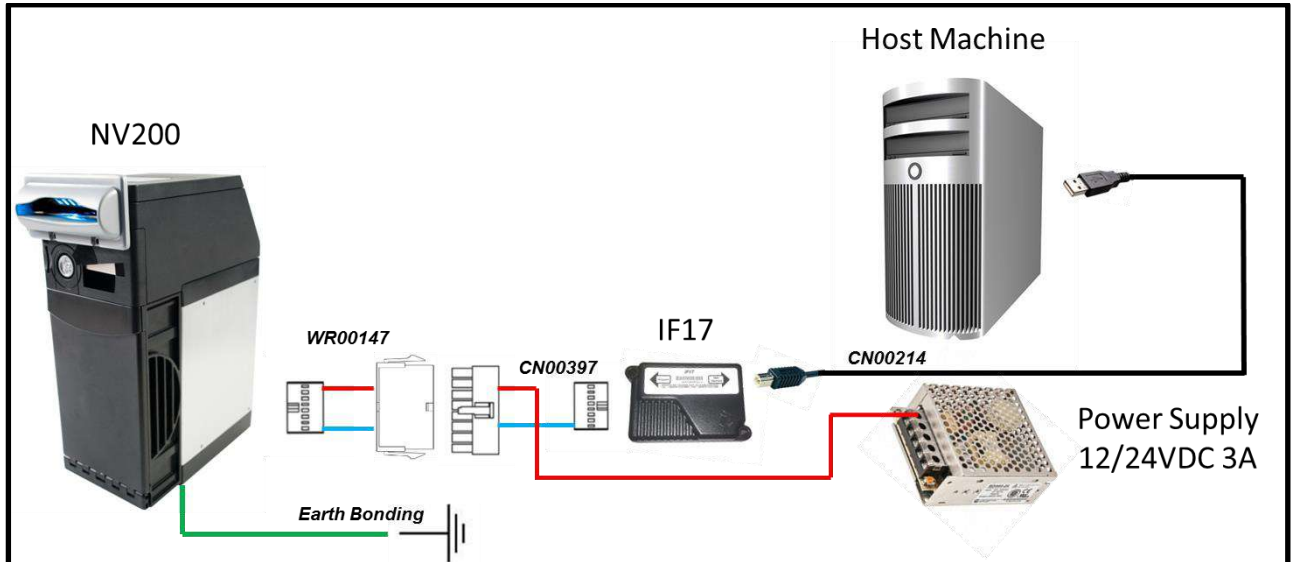

5.3.5.2 NV200 with Payout Module (SPO)

The drawing below highlights how to connect the SPO to a ccTalk host machine using available cables and interfaces from Innovative Technology Ltd.

This is not true ccTalk as the Tx and Rx pins are not joined, pin 1 and 5 can be connected if required.

For complete cable drawings please refer to [Appendix 10.4](#).

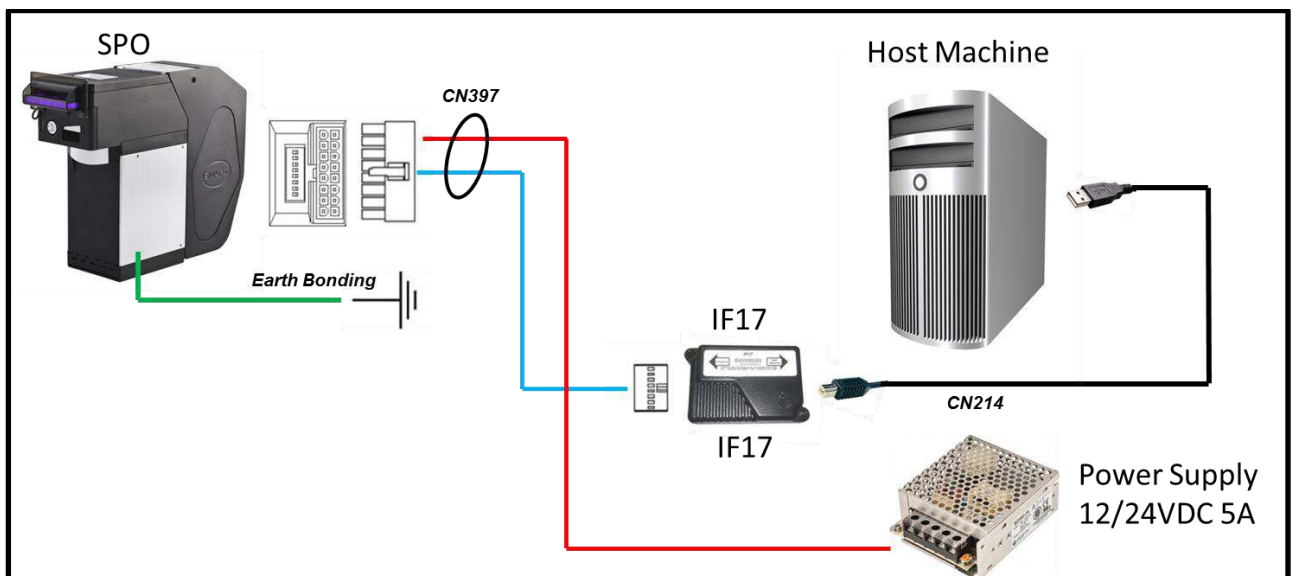

NV200 Family User Manual

[<< Back to Contents](#)

5.4 SIO and SI2

5.4.1 General Description

SIO (Serial Input/Output) is a very basic and low level serial communication interface. Messages are not echoed back. SIO uses 300 baud whereby SI2 uses 9600 baud.

	Caution!
SIO and SI2 are outmoded and not recommended for new developments!	

SIO is supported on the NV200 however as stated above it is not recommended for any new developments.

The data is formatted as follows:

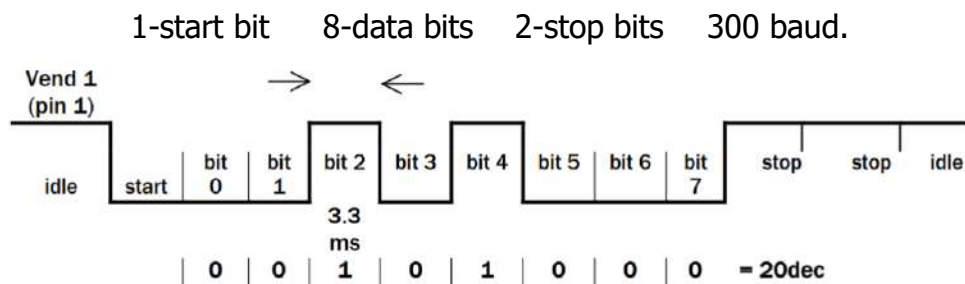

See below a list of recognised Receive and Transmit codes:

MESSAGE	DECIMAL VALUE	MESSAGE	DECIMAL VALUE
Inhibit C1	131	Note Accept on C1	1
Inhibit C2	132	Note Accept on C2	2
Inhibit C3	133	Note Accept on C3	3
Inhibit C4	134	Note Accept on C4	4
Inhibit C5	135	Note Accept on C5	5
Inhibit C6	136	Note Accept on C6	6
Inhibit C7	137	Note Accept on C7	7
Inhibit C8	138	Note Accept on C8	8
Inhibit C9	139	Note Accept on C9	9
Inhibit C10	140	Note Accept on C10	10
Inhibit C11	141	Note Accept on C11	11
Inhibit C12	142	Note Accept on C12	12
Inhibit C13	143	Note Accept on C13	13
Inhibit C14	144	Note Accept on C14	14
Inhibit C15	145	Note Accept on C15	15
Inhibit C16	146	Note Accept on C16	16
Un-inhibit C1	151	Note Not Recognised	20
Un-inhibit C2	152	Mechanism running slow	30
Un-inhibit C3	153	Top of form	40
		Bottom of form	
Un-inhibit C4	154	Channel 5 Note Rejected (fraud channel)	50
Un-inhibit C5	155	STACKER Full or Jammed	60
Un-inhibit C6	156	Abort During Escrow	70
Un-inhibit C7	157	Note may have been taken to clear jam	80
Un-inhibit C8	158	Validator Busy	120
Un-inhibit C9	159	Validator Not Busy	121
Un-inhibit C10	160	Command Error	255
Un-inhibit C11	161		
Un-inhibit C12	162		
Un-inhibit C13	163		
Un-inhibit C14	164		
Un-inhibit C15	165		
Un-inhibit C16	166		
Enable serial escrow mode	170		
Disable serial escrow mode	171		
Accept escrow	172		
Reject escrow	173		
Status	182		
Enable all	184		
Disable all	185		
Disable escrow timeout	190		
Enable escrow timeout	191		

Below is an example transaction:



NV200 Family User Manual

[<< Back to Contents](#)

Event	Validator	Decimal Value	Host
Note entered into validator	Validator Busy	120→	
Note accepted channel 2	Validator Ready	121→	
	Accept on channel 2	2→	
Note entered into validator	Validator Busy	120→	
Note not recognised	Validator Ready	121→	
	Note not recognised	20→	
Validator has returned note	Validator Ready	121→	
Software Inhibit Channel 4	Inhibit C4	←134	Inhibit C4
	Channel 4 inhibited	134→	
Software Enable Channel 4	Uninhibit C4	←154	Uninhibit C4
	Channel 4 inhibited	154→	
Status Report		←182	Status Request
	Status Requested	182→	
3 byte status message	Inhibit status Channels 1-8	Byte 1→	
	Inhibit status Channels 9-16	Byte 2→	
	Escrow On (=1) / Off (=0)	Byte 3→	
Turn on Escrow Mode		← 170	Enable Escrow Mode
	Escrow Mode Enabled	170→	
Note accept in Escrow Mode			
Note entered into validator	Validator Busy	120→	
Note Accepted Channel 2	Validator Ready	121→	
	Accept on Channel 2	2→	
		←172	Accept Note in Escrow
	Accept Escrow	172→	
	Accept on Channel 2	2→	

5.4.2 Pinout

The connector number can be found below:

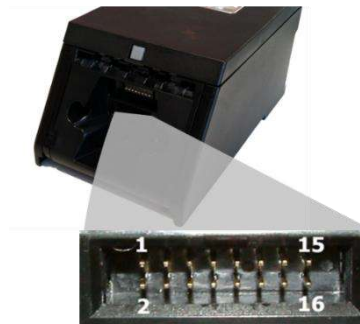

NV200 Connector

Pin	Name	Type	Description
1	Vend 1	Output	Serial Data Out (Tx)
15	+ Vin	Power	+12/24VDC Supply
16	0V	Power	0V Supply (GND)



[<< Back to Contents](#)

5.5 MDB

5.5.1 General Description

MDB (Multi-Drop Bus) is an open standard in the vending industry specified by NAMA (National Automatic Merchandising Association) so that all vending and peripheral equipment communicates identically. MDB uses a master-slave model where the VMC (Vending Mechanism Controller) is the master that can communicate with up to 32 slaves (e.g. banknote validator or coin acceptor). Currently only the NV200 and the NV200 with the Payout module are compatible. MDB documentation can be found in [Section 1.1](#).

5.5.2 Pinout

The connectors for the NV200 can be seen below:

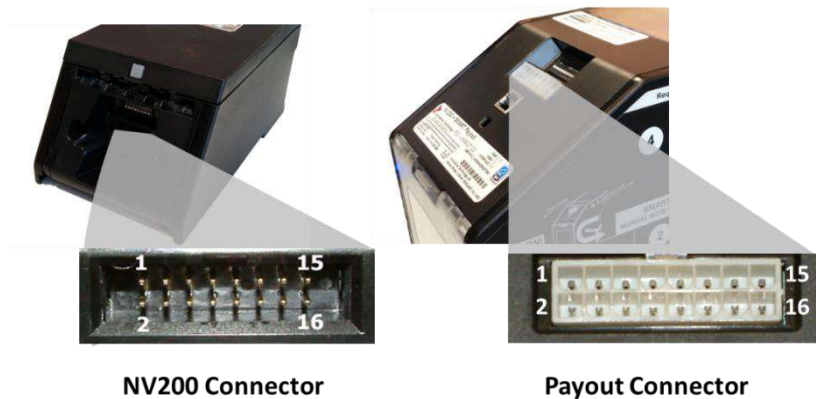

<i>Pin</i>	<i>Name</i>	<i>Type</i>	<i>Description</i>
1	TTL Transmit (Tx)	Output	Serial Data
2	Opto Emitter TXD	Output	Opto-isolated (if connecting directly to host)
5	TTL Receive (Rx)	Input	Serial Data
6	Opto+ Rx D	Input	Opto-isolated (if connecting directly to host)
7	Opto Collector Tx D	Output	Opto-isolated (if connecting directly to host)
10	Opto- Rx D	Input	Opto-isolated (if connecting directly to host)
15	+ Vin	Power	+12/24VDC Supply
16	0V	Power	0V Supply (GND)

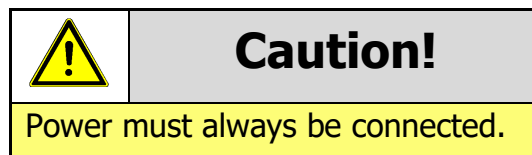

5.5.3 IF5 Interface

The IF5 allows the NV200 to operate with MDB machines no matter the voltage (24/34/48). As the NV200 can operate at 24v this is only required for applications higher than 24v.

A link to the IF5 can be found below.

Webshop Link: <http://innovative-technology.com/shop/accessories/if5-mdb-voltage-converter-detail>



5.6 Pulse

5.6.1 General Description

Pulse can be used for the acceptance of up to 16 channels. When a note is recognised vend 1 (pin 1) will pulse a pre-set number of times. The amount of pulses as well as the high/low pulse ratio is configurable.

	Caution!
Pulse is an unsecure interface and should not be used for new developments!	

The Pulse interface is not in the standard NV200 files and needs to be requested from support at support@innovative-technology.com

5.6.2 Pinout

Pin	Name	Type	Description
1	Vend 1	Output	Credit Output Pulse Stream
5	Inhibit 1	Input	Inhibit Input Channel 1
6	Inhibit 2	Input	Inhibit Input Channel 2
7	Inhibit 3	Input	Inhibit Input Channel 3
8	Inhibit 4	Input	Inhibit Input Channel 4
9	Busy	Output	Output Busy Signal
10	Escrow	Input	Input Escrow Control
15	+ Vin	Power	+12VDC Supply
16	0V	Power	0V Supply (GND)

5.6.3 Inhibit Control

The Inhibits can be used to either enable or disable the acceptance of those banknotes programmed on channels 1, 2, 3 and 4. The Inhibits are internally held high and must be set to low (GND) to enable banknote acceptance. If no Inhibit is set to low (GND) the Master Inhibit is set and the NV200 is disabled.

5.6.4 Escrow Control

The NV200 has a single note escrow facility. This allows the NV200 to hold onto the note once validated, only stacking the note into a cashbox when the host machine confirms the Vend operation has been completed. Please see below:

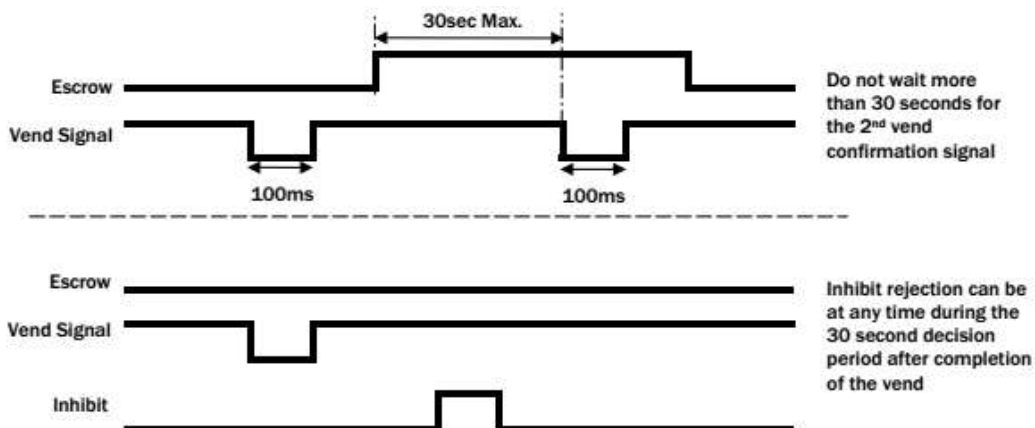

	Caution!
Only book the credit on the second Vend pulse!	

5.6.5 Busy Control

When the busy line is high the unit is in the process of accepting a note, and a vend signal is likely to appear shortly afterwards.

5.6.6 Low Power Mode

The Low Power Mode can be used to reduce the power consumption of the NV200 when idle. When the Low Power Mode option is set, the NV200 goes into the Low Power Mode after about 6 seconds after the NV200 is powered up and remains in this state until a note is entered. Following a note insertion, the NV200 returns to Low Power Mode approximately 1 second after a credit is given or note is rejected. Please see below for timing diagram and further details.

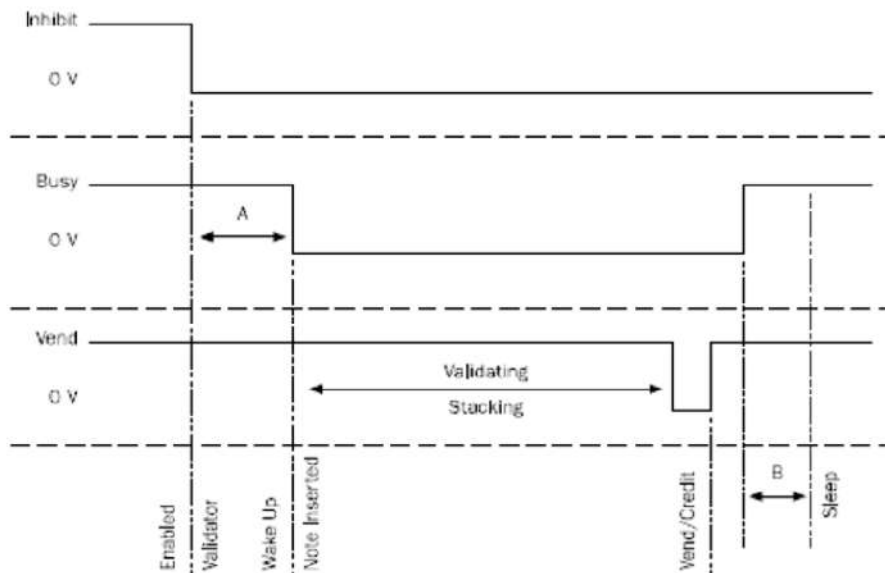

	Caution!
In Low Power Mode the front sensor is checked every second which can lead to a delay in accepting the note when it is presented!	

5.6.7 Credit Hold Function

If this function is enabled the NV200 will take notes as normal but will wait until the escrow line is toggled low/high before it will give out the pulses per denomination as set. After the pulses, have been given, the NV200 will wait for another low/high toggle until the full value of credit pulses are given.

For example, with a setting of 2 pulses per dollar, a five-dollar bill will give 2 pulses 5 times.



[<< Back to Contents](#)

A Typical use of this option would be for a Pool table with a game price of \$1. A \$5 note could be inserted, a button pressed to toggle the escrow line and the pool balls would be released. The Validator holds onto the remaining credits until the game has finished and the button is pressed again allowing the next game to begin, this continues until all the credits have been used.

The busy line remains low throughout the whole process and the NV200 remains inhibited until all pulses are given.

5.6.8 IF15 Interface

The IF15 is an interface that allows serial SSP to be used in machines without the need of updating the machine software. The IF15 is connected between the NV200 and the host machine. The IF15 communicates with the NV200 in serial SSP which gives more security along the length of the cable. The IF15 should be mounted close to the host machine control board where the IF15 converts to the pulse connection.

If the inhibits aren't required connect them all to the GND line, it will leave all the channels constantly enabled.



6 SOFTWARE INSTALLATION AND CONFIGURATION

6.1 Introduction

The NV200 leaves the factory programmed with the latest dataset and firmware files. However, it is important to ensure the device is kept updated throughout its operational life. This section provides a brief overview of the various update procedures with the NV200. For detailed instructions please refer to the relevant manual package supplied with the software.

The extra modules are updated through the NV200, as such once the programming has been completed on the validator it will begin to update the connected modules e.g. payout, ticket.

6.2 Software Downloads

All software from Innovative Technology Ltd is free of charge and can be downloaded from the website www.innovative-technology.com/support/secure-download once registered. To create an account complete the 'create an account' form.

As of June 2016 the ASIIC chip used in the NV200 was made obsolete by the manufacturer. As such a new board revision with a different processor was released. This resulted in a different hardware revision and firmware version, please see below:

1. The revision has been increased to Revision 30 (from 25).
2. The NV200 with ST chipset will have its own 'validator type' referenced in the dataset name (see below):

Previous NV200 - GBP58620

NV200 with ST chipset - GBP58G20



Ensure the correct version of firmware is being used for the product.

6.2.1 Drivers

The ITL drivers suite allow any ITL validator to be connected to a Windows device. If connecting via an IF17 these steps shouldn't be required as the drivers are signed so Microsoft should install them automatically. If this isn't the case or your computer is disconnected from the network, there is a standalone package included within the driver downloads.

6.3 Dataset/Firmware Programming

6.3.1 Validator Manager

6.3.1.1 General Description

Validator Manager is a utility which allows the user to reprogram any of ITL's currently supported devices.



NV200 Family User Manual

[<< Back to Contents](#)

Admin rights are required during installation. The validator must be in SSP for the Validator Manager to detect the device.

6.3.1.2 System Requirements

- Windows XP SP3 or above
- .Net Framework 4
- 2015 C++ Redistributable
- 256mb ram
- 50mb hard disk free
- ITL Drivers
- Connected NV200 with an active com port
- The NV200 must be in SSP, for information on how to do this see [Appendix 10.5](#).

	Caution!
Occasionally one of the dll's (itdata1.dll) used in Validator Manager are flagged as a Trojan, this is a false positive and if this happens add a rule to your antivirus to allow the file to run.	

6.3.1.3 Hardware Setup

As outlined in [Section 5.2.3](#) there are many ways to connect the NV200 to the computer. Below is a typical example:

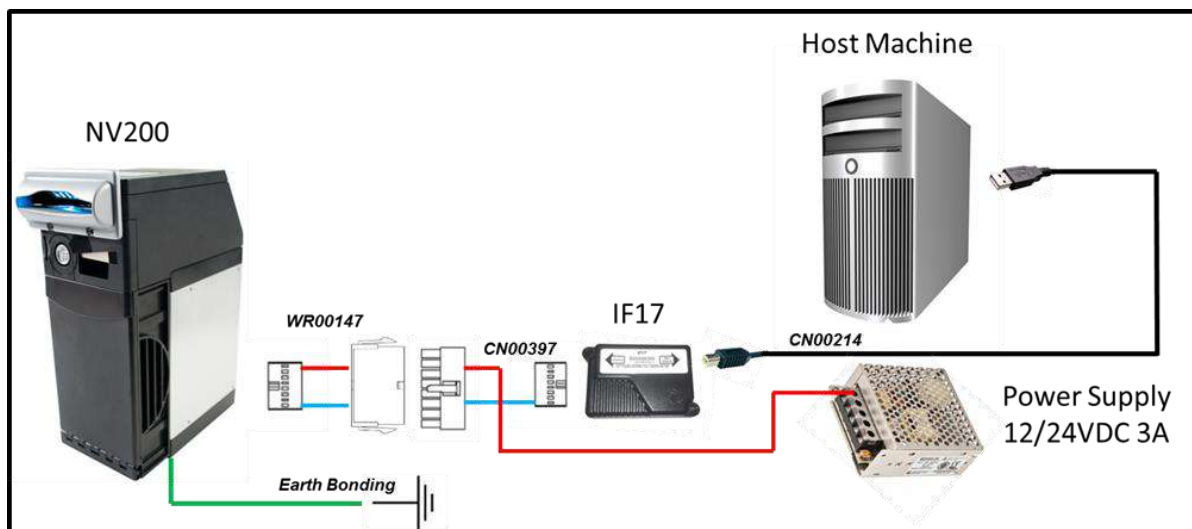

For further configuration options please consult [Section 5.2.3](#).

6.3.1.4 Switching to Programming Mode (SSP)

Before programming via the Validator Manager, the NV200 needs to be switched to its programming mode (SSP interface) as explained in [Appendix 10.5](#).

6.3.1.5 Programming the device

Once the unit is switched to SSP, open Validator Manager and click detect devices. This will scan all active com ports for a unit, if your NV200 fails to connect please ensure the correct drivers are installed and the unit is in SSP.

By selecting the Program tab, the NV200 can be programmed. To begin the upload, click open file, browse to the file location (usually Downloads) and click OK.



NV200 Family User Manual

[<< Back to Contents](#)

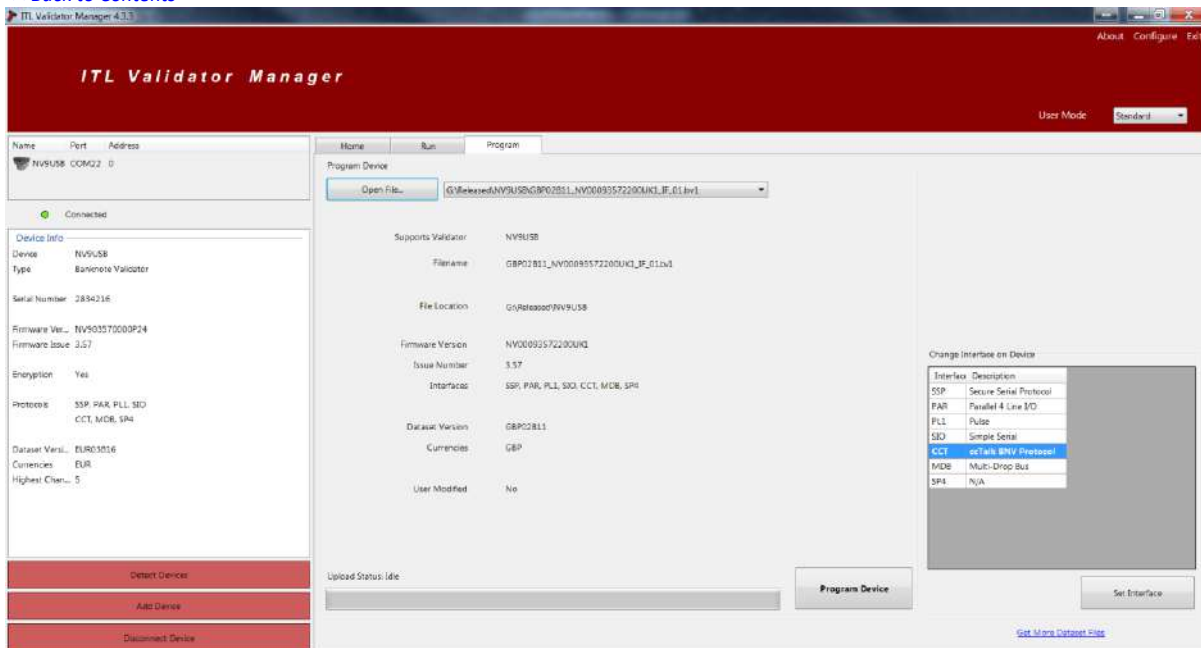

Recently the processor has been changed leading to 2 different versions of firmware being available. If the wrong file for this validator is selected the 'Program Device' button will be greyed out. Details of the change can be found in [Appendix 10.10](#).

Once the file has been selected its information will be populated and the Program device tab will become active. Select 'Program Device', the unit's bezel will begin to flash signalling the update has begun.



Caution!

Interrupting the download process can result in the unit entering a non-functional state, once the process has started it cannot be halted.

When completed the unit will restart and a pop up box will appear saying Device Programming Complete.

6.3.2 DA3

6.3.2.1 General Description

The DA3 is a hand-held validator programming system that enables the user to re-program ITL banknote validators in the field, without the use of a PC. Dataset and firmware files for different validator models can be stored on the DA3. Once programmed the user can update or override existing software as well as test the functionality of the validator, away from the host machine.



6.3.2.2 System Requirements

- Windows XP SP3 or above
- .Net Framework 4
- 2015 C++ Redistributable
- 256mb ram
- 50mb hard disk free



[<< Back to Contents](#)

- ITL Drivers
- Connected DA3 with active com port

6.3.2.3 Re-programming the DA3

To program the DA3 Device Programming system (DPS) needs to be used, this can be downloaded from our website. The DA3 connects to the PC through the USB port. Once the software is installed import the dataset into the DPS before uploading it to the DA3 internal memory.

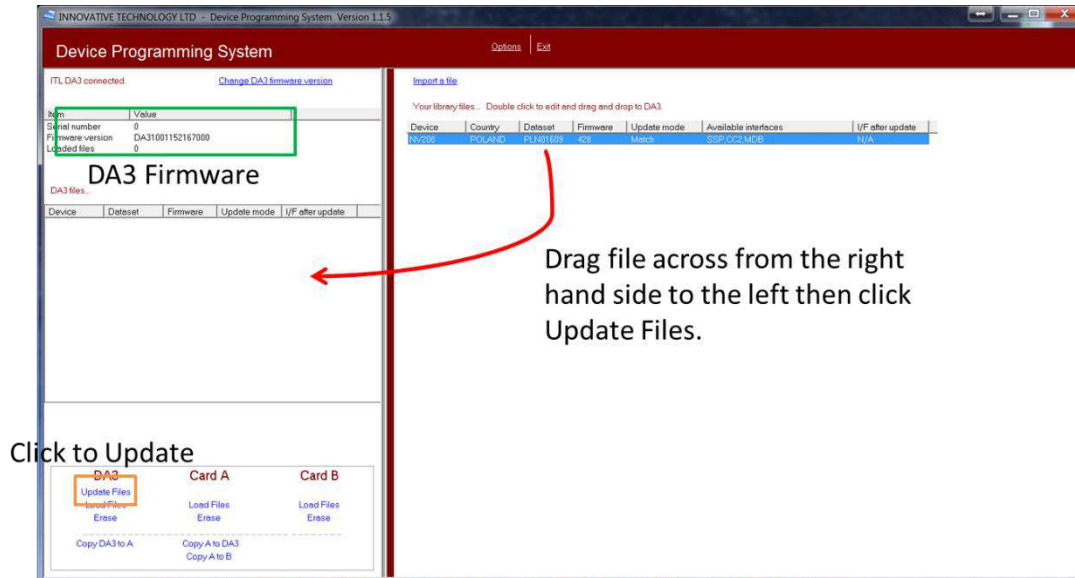

This method is a match download so only a dataset with a matching denomination code will be programed onto the validator. E.g. GBP06615 -> GBP06620.

Should any more information a full guide of how to create an update card can be found in the software manual, a link to which can be found in [Section 1.1](#).

Once the files are loaded onto the DA3 the Validator can be updated. For this a ribbon cable needs to be connected between the validator port on the da3 and the validator. The host machine cable connected to the spare port on the da3 as shown below:



Once the unit is connected, ensure it is in SSP, press the play button in the middle, the da3 will begin to download. If there is an issue the 'BNV Match Download' LED will begin to flash.



NV200 Family User Manual

[<< Back to Contents](#)

Should an error occur whilst updating the unit via the DA3, a flash code will be displayed on the DA3 Mode LED indicator as shown below:

1 Long flash followed by –

Number of SHORT flashes	Indicated Status / Error
2	No validator connection found
3	No valid download files found
4	Download fail
5	Memory card fail

6.3.3 SD Card

6.3.3.1 General Description

The NV200 can also be reprogrammed through the SD slot on the front of the unit; to program a card to update the unit NV Card Utilities must be used. NV Card Utilities allows the user to create update cards for the NV200 family of products.

6.3.3.2 System Requirements

- Windows XP SP3 or above
- .Net Framework 4
- 2015 C++ Redistributable
- 256mb ram
- 50mb hard disk free
- ITL Drivers
- Connected DA3 with active com port
- NV Card Utilities
- Data Flash Card (PA01121) / SD Card (ICO2017)

6.3.3.3 Re-programming via SD Card



A full guide of how to create an update card can be found in the software manual (GA02037), a link to which can be found in [Section 1.1](#). Once the appropriate card has been generated insert it into the card slot on the NV200. The bezel will begin to flash blue and pink, once the download is complete the bezel will go solid green. Remove the SD card, the NV200 will begin to update any attached device (Payout, Ticket and/or TEBS).

If a device is attached its LED Status Indicator will flash indicating the unit is being updated.



Caution!

Interrupting the download process can result in the unit entering a non-functional state, once the process has started it cannot be halted.

6.3.4 Remote Updates

The unit can be updated through an SSP command which sets the validator into an update mode before downloading the firmware file. Details of how this process is implemented can be found in ITL's eSSP Implementation Manual (GA973) and is available on request.





Caution!

This is a complex operation and failure to implement correctly may damage units.

6.3.5 SMART Update

Smart update is a utility which bundles up a regions dataset into one file which can be placed on an SD card, this can then be inserted into the SD card slot at the front of the NV200 and it will update with the latest version of the dataset currently loaded onto the unit. No settings will be altered during the update only the dataset and firmware.



7 ROUTINE MAINTENANCE

7.1 Introduction

Depending upon the environment the NV200 is running in it may require cleaning, belt changing or note path clearing.

7.2 Cleaning the NV200

Disconnect the power **BEFORE** carrying out any cleaning operations to avoid the risk of causing damage to the validator.

7.2.1 Recommended Cleaning Intervals

Clean the optical lenses every 6 months or more if the unit is in a particularly harsh environment. Dirt, dust or other residue leads to bad note acceptance and other performance degradation. Please refer to the section below for comprehensive cleaning instructions.

7.2.2 Cleaning the Validator



Caution!

Do not use solvent based cleaners on any part of the NV200 unit.

Do not use solvent based cleaners such as alcohol, petrol, methylated spirits, white spirit or PCB cleaner. Using these solvents can cause permanent damage to the units; only use a mild detergent solution as directed below.

The NV200 note path can be cleaned with the head still fitted to the chassis, although it may be easier to remove the head from the chassis assembly.

To remove the NV200 head unit, first lift the silver head release catch located on the front of the NV200. Finally, slide the head unit forward and lift it off the chassis.



WARNING!

Disconnect power **BEFORE** any cleaning operation

[<< Back to Contents](#)

To open the note path cover, pull the top cover release latch forward (towards the bezel) and lift the cover as shown below (it is recommended to also remove the bezel to allow correct cleaning of the note path guides):



The note path is visible and can be cleaned. Carefully wipe the surfaces with a soft lint free cloth that has been dampened (NOT wet) with a water and mild detergent solution (e.g. household washing up liquid) - be very careful when cleaning around the sensor lenses and make sure they are clean and dry before closing the cover and powering the unit.



Caution!

Do not use any lubricants.

Do not lubricate any of the note transport mechanism or any part of the note path, as this can affect the operation of the validator.



WARNING!

Do not try to disassemble

Do not attempt to disassemble the validator head – trying to do this could cause personal injury and will damage the unit beyond repair.

7.2.3 Cleaning the TEBS Cashbox

Remove the cashbox as outlined in [Section Error! Reference source not found.](#), this provides access to the moving parts within the TEBS cashbox. Once the cashbox has been removed, detach the NV200 head this provides access to the drive gears.

Manually turn the stacker drive this will move the stacker forward, when at the full extension there is a tactile bump. This will hold the stacker out allowing compressed air (Max pressure = 5 bar) to be blown into the unit.

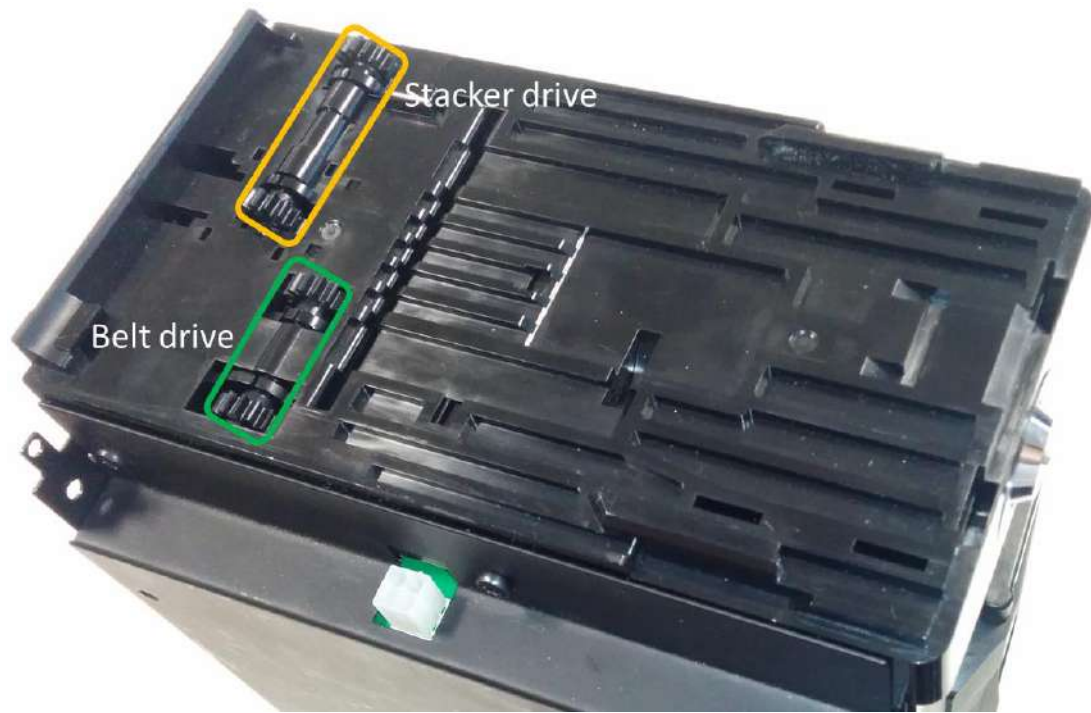

Once the debris has been cleared check foam strips on the stacker to ensure they are not damaged, if not move the stacker back into the rest position. If they are damaged, remove the stacker plate by pushing up and replace the strips with ITL part number LB2034.

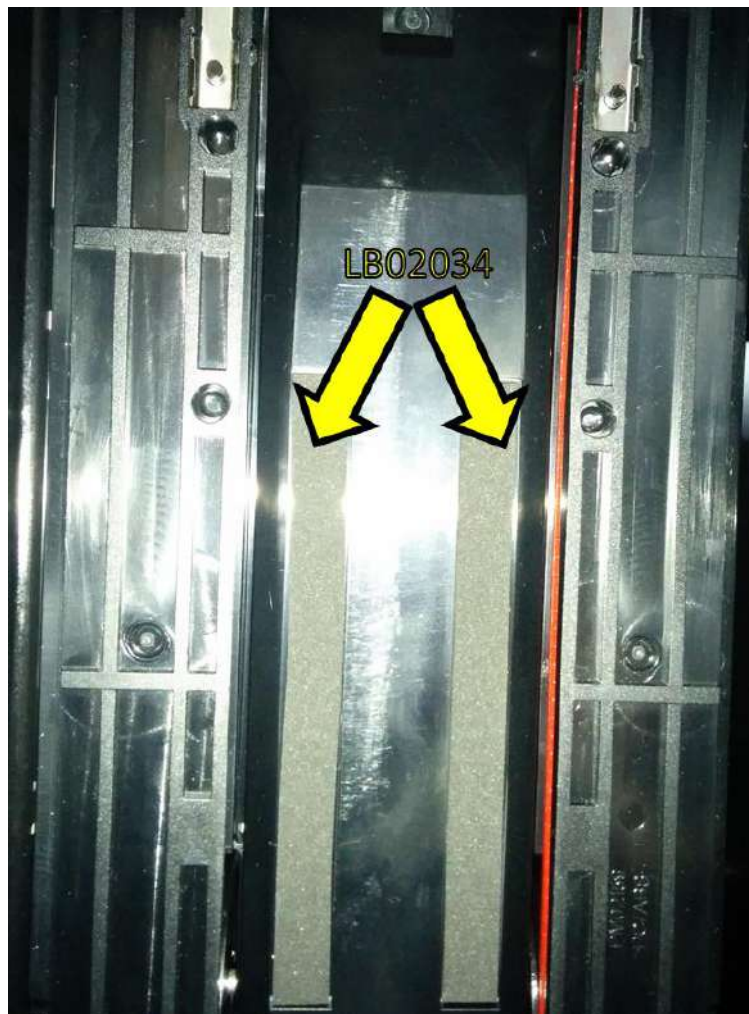

[<< Back to Contents](#)

To clean the belts apply a small amount of Pro-cleanse 7000 (isopropyl alcohol microfibre cloth and wipe the belts as shown below, ensure to rotate the belt drive mechanism so that all the belt is cleaned.

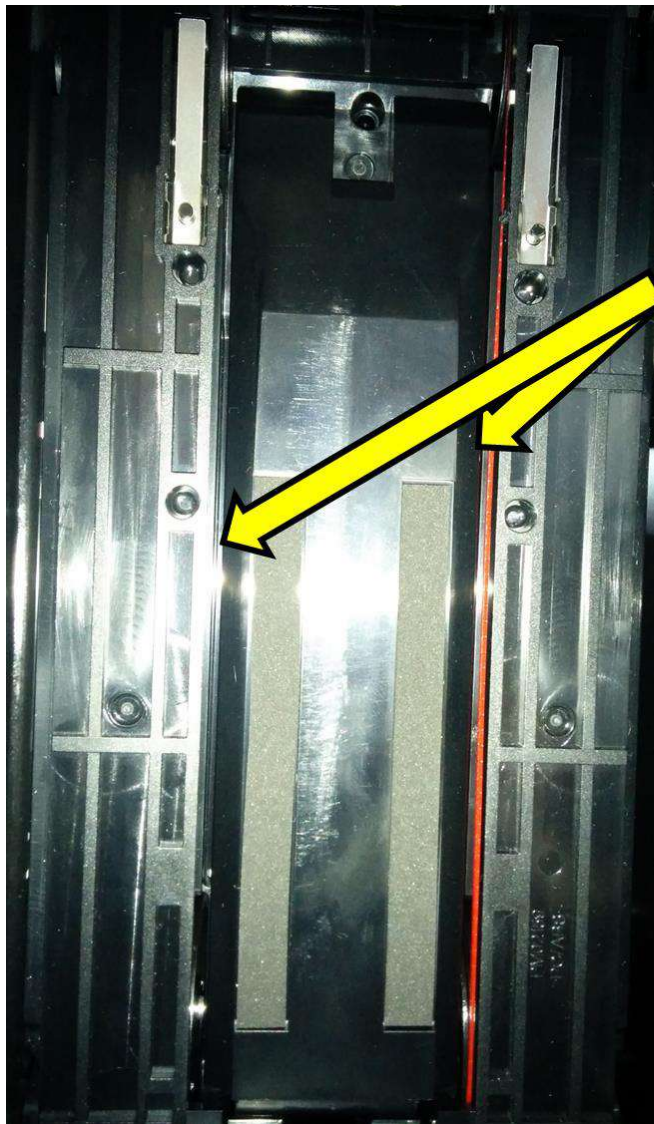

Run cloth down the TEBS belts, ensure you rotate the belt drive so that all of the surface has been cleaned.

7.2.4 Cleaning the Ticket Module

To Clean the Ticket module, open the printer by squeezing the clips on the top of the SMART Ticket and lifting the lid.

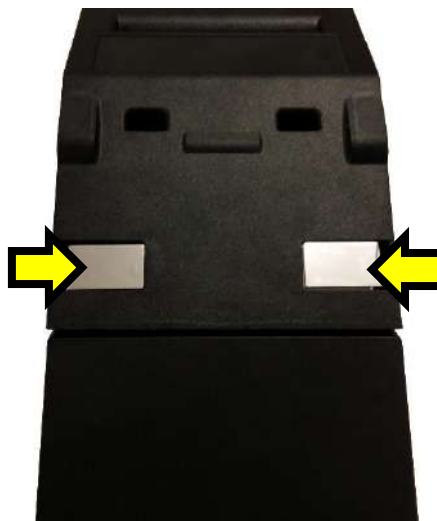

NV200 Family User Manual

[<< Back to Contents](#)

When opened the Ticket Path for the Fan Fold (left) and Roll Printers (right) are accessible, as shown.



Part of the SMART Ticket needs to be removed so the whole path can be cleaned.

On the Fanfold Ticket the PM01018 is used to separate/burst the perforated tickets, whereas on the roll it is only used to guide the paper, the part is shown in situ below.

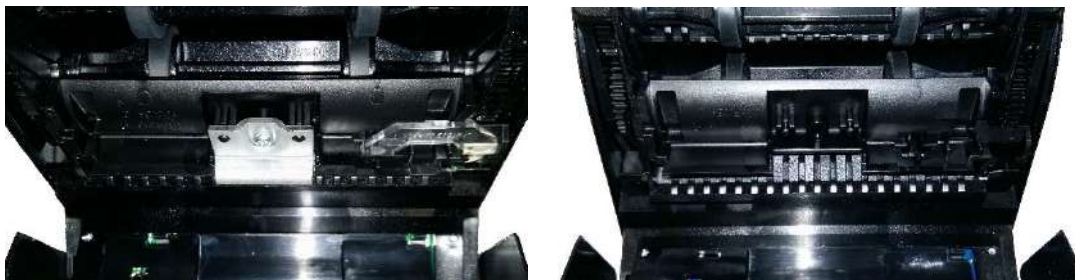

Remove this part by pressing into a lug on the side with a tool (e.g. a screwdriver) and lifting the PM01018 out of position.

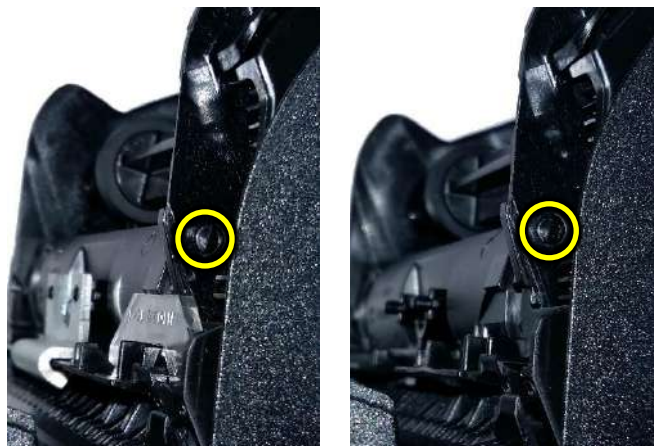

NV200 Family User Manual

[<< Back to Contents](#)

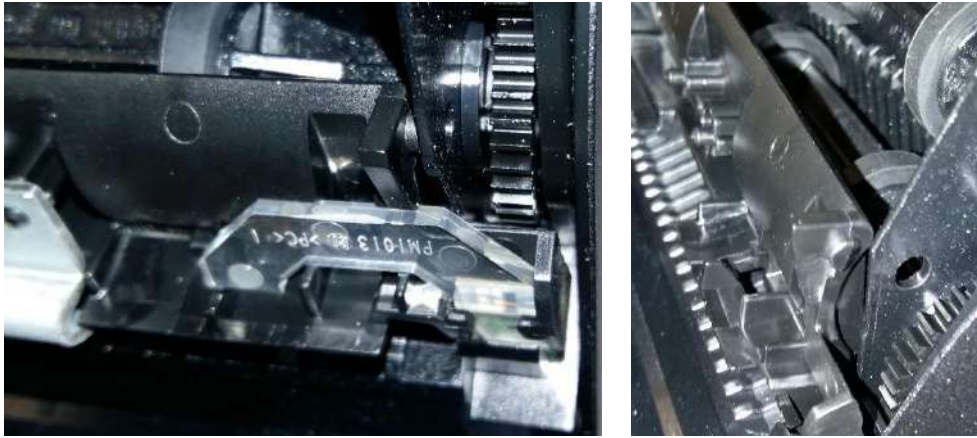

There are Lugs on both sides, when one is unclipped, the other can be removed.

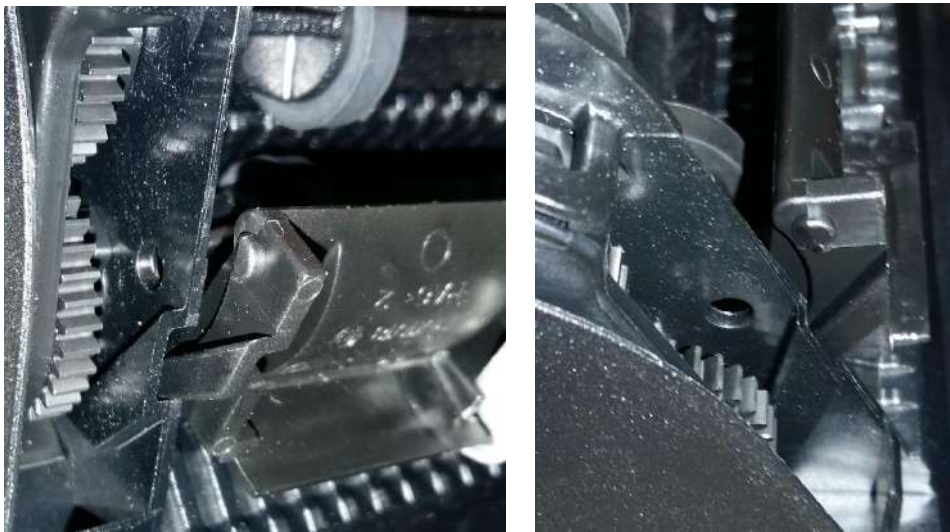

It can then be lifted out of position to reveal the rest of the ticket path.



NV200 Family User Manual

[<< Back to Contents](#)

Compressed air (Max pressure = 5 bar) should be used to clean the rollers and ticket path of debris. The ticket path can then be wiped off with a soft lint free cloth, this can be dampened (NOT wet) as required.

For Roll Tickets, the printer should be opened so the cutter can have debris removed.

Pushing back on the white lever will pop the printer platen out of position.

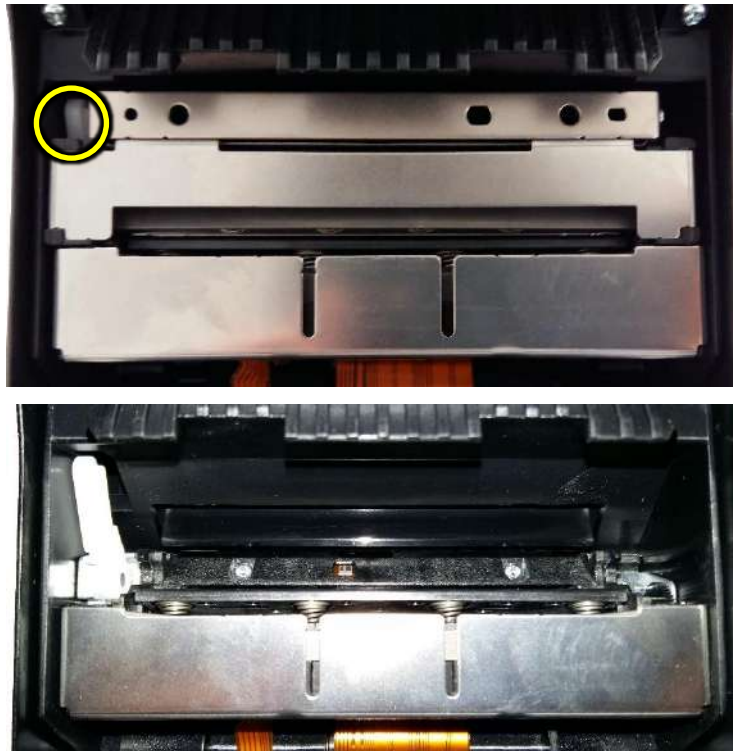

Both the Printer body and the platen (the removed part) can be wiped off with a dampened (NOT wet) soft lint free cloth.

The Platen is reattached by pushing it back into position.

The detached plastic for the note path can be repositioned by aligning the plastic guides and pushing the nodules into position.



The Ticket Path can then be closed and the unit can be powered.



8 FIRST LEVEL SUPPORT

8.1 Bezel LED Flash Codes

If there is a configuration or other error, the NV200 bezel will flash a pattern to indicate what error it is experiencing.

A summary of the Bezel Flash Codes for the NV200 is below:

Flashes		Indicated Status / Error	Recommended Action
Red	Blue		
1	1	Note Path Open	Close the lid of the NV200 validator it will click into place as it shuts.
	2	Note Path Jam	<ol style="list-style-type: none"> 1. Power down the NV200 2. Open the NV200 using the silver catch on top and inspect the note path for any note debris 3. If there isn't any evidence of a note carefully remove the NV200 from the base using the silver catch on the front. 4. A note could be just sticking out from the cashbox, remove power and the NV200 head. 5. If a note is visible remove the note. 6. Re-attach the head and power. 7. If the jam isn't cleared remove the cash bag as described in Section 9.1.3.2.
	3	Unit Not Initialised	Initialise the unit as shown in Section 9.5 .
2	1	Cashbox Removed	<p>Insert the cashbox.</p> <p>If its a TEBS cashbox and the error is displayed with the cashbox inserted, remove the outer housing and check the barn door flag is operating as explained in Section Error! Reference source not found.</p>
	2	Cashbox Jam	Follow the steps as advised in Section 9.1 .
	3	No TEBS Detected	<p>Remove the NV200 head by lifting the silver latch on the front of the unit. Replace the unit ensuring the NV200 is flush with the front of the TEBS unit.</p> <p>If the unit is displaying this error but is connected to a standard cashbox the NV200 cashbox flag should be changed in Validator Manager. A guide to which can be found in Appendix 10.6. If this doesn't solve the issue attempt a power cycle of both the NV200 and TEBS.</p>
	4	Barcode Fail	<p>If a new bag had been inserted and the unit fails to read the barcode; attempt a power cycle of the TEBS base by removing and replacing the 4 pin Molex on the left-hand side of the unit.</p> <p>If the unit doesn't recover a new bag will need to be inserted, replace the bag as outlined in Section 4.3.2</p>



NV200 Family User Manual

[<< Back to Contents](#)

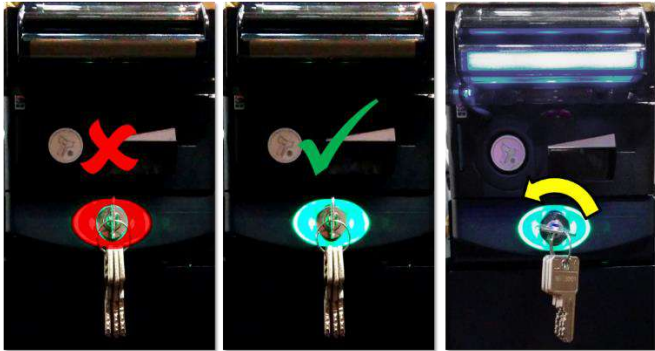
	5	Cashbox Unlocked	Issue an unlock command to the TEBS, physically unlock and relock the unit ensuring the lock has been completely turned.
			
	6	Currency Mismatch	Remove the current TEBS bag and reinsert a new bag.
	7	Firmware Error	Please contact ITL support.
3	1	Firmware Checksum Error	There has been an issue with the attempted download, retry the download with the recovery section on validator manager, if this fails arrange for the unit to be returned to the nearest repair centre; details of which can be found on our website.
	2	Interface Checksum Error	The firmware loaded doesn't contain the primary interface from the previous firmware. Download with the IF file containing the correct protocol.
	3	EEPROM Checksum Error	There has been an issue with the attempted download, retry the download with the recovery section on validator manager, if this fails arrange for the unit to be returned to the nearest repair centre; details of which can be found on our website.
	4	Dataset Checksum Error	
4	1	Power Supply too Low	Check the voltage on your power supply is within the specified voltage range as outlined in Section 3.4 . If the voltage appears to be correct, please check to ensure the power supply voltage doesn't vary by more than 10% under maximum current draw.
	2	Power Supply too High	Check the voltage on your power supply is within the specified voltage range as outlined in Section 3.4 . If the voltage appears to be correct, please check to ensure the power supply voltage doesn't vary by more than 10% under maximum current draw.
	3	Card Format	The data card inserted is incorrect, format the card using the latest NVCardUtilities.
	4	Payout Reset	The Smart Payout is in the process of resetting, wait for it to recover.
5	1	Firmware Mismatch	The Firmware on the device connected doesn't match the firmware on the NV200. Ensure the Firmware supports the connected device. If a payout is connected, ensure Dipswitch 7 is



		off.
2	Payout Jam	The smart payout has encountered an issue and a note has jammed, follow the steps as described in Section 9.2 .
4	Payout Jam recovery in progress	The smart payout encountered a jam and is attempting to recover. 5 notes will be moved to the cashbox, from the payout. Once the unit has completed this it will go back in service.

8.2 NV200 Module Flash Codes

Each additional module for the NV200 has its own flash codes, below the following flash codes are outlined and recommended recovery procedures are explained.





8.2.1 TEBS Lock Flash Codes

The TEBS cashbox can display a flash code on the lock cam.

Flashes		Indicated Status / Error	Recommended Action
Red	Blue		
3	2	Camera not Responding	Arrange for the unit to be returned to the nearest repair centre; details of which can be found on our website.
3	3	EEPROM Error	
3	4	TEBS Log CRC Error	Send the Clear TEBS Log command through validator manager this will reset the logs and the error should clear.

8.2.2 Payout Module Flash Codes

An LED on the rear of the payout module can flash error codes to aid troubleshooting.

Status Indicators		Flashes	Indicated Error	Recommended Action
Red	Green			
		0	No LEDs lit	Ensure the required power is being provided
		1	Motor / barcode error	Arrange for the unit to be returned to the nearest repair centre; details of which can be found on our website.
		2	Note sensor error	
		3	EEPROM error	
		4	Payout jammed	Remove trapped note (see Section 9.2 of this manual set)
		5	Diverter error	Switch Payout module DIP switch 8 on and off with power on (diverter position shown in Section 9.3)
		0	Both LEDs on (no flash)	Turn power on and off
		1	Power reset	Providing information, not an error.
		2	Wakeup from low power	Providing information, not an error.
		3	Software reset	Providing information, not an error.
		4	Software command	Providing information, not an error.
		5	User manual reset	Providing information, not an error.
		6	Power supply issue	Check power supply is within specification as outlined in Section 3.4 .
7	Unknown cause	Ensure the unit is grounded.		
		1 every second	None	Providing information, not an error.



8.2.3 Ticket Module Flash Codes

The Button on the Rear of the SMART Ticket can flash Error codes to aid trouble shooting.

Flashes		Indicated Error	Recommended Action
Red	Yellow		
	Flashing	No Issue	Providing information, not an error.
Solid	Flashing	Paper Low	Refill the Tickets.
1	1	No Connection detected	1. Make sure a NV200 is connected. 2. Check the NV200 is powered. 3. Check the Firmware on the NV200 supports the SMART Ticket.
	2	Initialisation Fail	Contact repairs@innovative-technology.com .
	3	No Print Head	Reattach printer platen see Section 7.2.4 .
	4	Ticket Path Open	Shut the SMART Ticket.
2	1	No Paper	Insert paper into the printer
	2	Tab not found	Ensure the Fan Fold paper is inserted the correct way around.
	3	Load fail	1. Ensure there is nothing blocking the paper entering the printer and reinsert the paper. 2. Remove the printer platen see Section 7.2.4 , move the paper feed roll, reinsert the platen and reinsert the paper.
3	1	Diverter not opened	Ensure the NV200 diverter plunger isn't covered and there is nothing stopping the SMART Ticket Actuator from opening.
	2	Diverter not closed	Ensure there is nothing holding the diverter plunger down and there is nothing stopping the SMART Ticket Actuator from closing.
	3	Burst fail	Open the Ticket Path and remove the ticket that failed to print. Ensure the unit is clean and PA01132 is fitted correctly.
	4	Cut fail	Open the ticket path and remove the ticket that failed to print. Ensure the printer is clear of any debris or blockages.
	5	Unknown jam	See Section 9.4 for information on how to clear jams.
4	1	Unknown error	Reset the unit.
	3	Card Format	The inserted card must be in a Fat 32 format remove and format the card.

8.3 Checking power connections to the unit

Check to ensure the power cables are correctly connected to the unit as shown below:



[<< Back to Contents](#)

8.3.1 NV200 Connections

Ensure the NV200 has power applied, the pin-outs for the relevant connection can be found in [Section 5.2.2](#).

The NV200 connector and the IF17 connector are similar, the only difference is the power cables in pins 15 & 16 on the NV200 connector.



8.3.2 TEBS Connections:

Ensure both the NV200 and TEBS cashbox have power applied, the pin-outs for the relevant connection can be found in [Section 5.2.2](#).

The NV200 connector and the IF17 connector are similar, the only difference is the power cables in pins 15 & 16 on the NV200 connector.

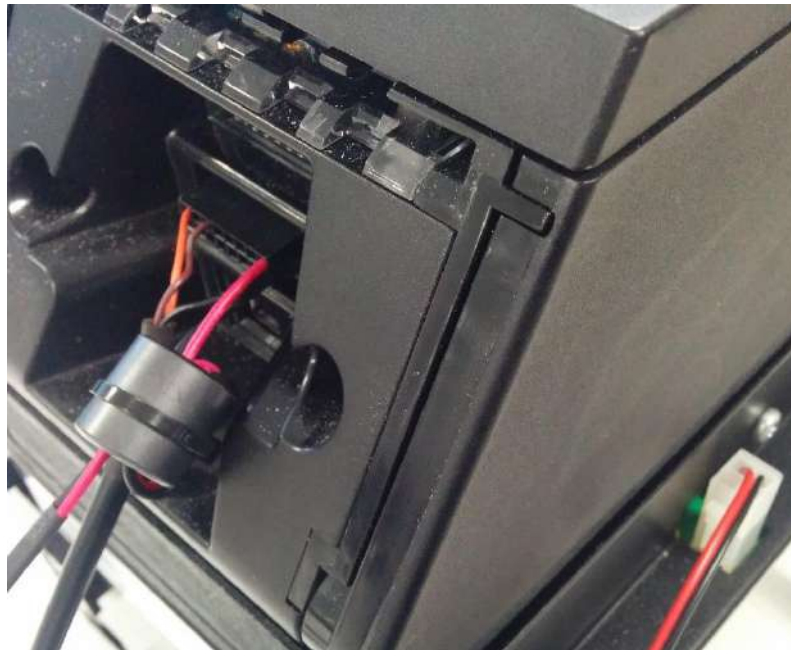

[<< Back to Contents](#)

8.3.3 Smart Payout Connection:

The Payout module connector is a 16-pin molex as outlined in [Section 2.4.1](#), ensure the cable is correctly seated.

If the TEBS cashbox is fitted it also needs to be connected to power as explained in the section above.



8.3.4 Smart Ticket Connection:

The SMART Ticket uses the same 16 pin molex connector as the SMART Payout, additional pins need to be populated to carry communications to both the NV200 and printer. More details of this can be found in [Section 5.2.2](#).

An additional 4-pin molex connector is required for power, both must be connected before the unit will identify as a Smart Ticket. When power is supplied to the ticket the LED on the rear will be illuminated.

If the TEBS cashbox is fitted there needs to be an additional 4-pin molex connected to power as explained in [Section 5.2.2](#).



8.3.5 Checking the Supply Voltage

If the power supply seems to be powered and connections to the unit are in place, yet the unit isn't powered, check the voltage output from the power supply is sufficient and the polarity is correct. If this isn't the issue replace the cable as it may have been damaged. Should this not resolve the issue, contact your local repair centre, details of which can be found on our website.

8.4 Communication with the Host

If there is no communication with the host check the communication cable, typically this will be the IF17 and the port on the host system.

Ensure the cable is connected to the IF17 correctly, so the connectors are fully seated and the usb cable is connected to the computer.

NV200 Family User Manual

[<< Back to Contents](#)



If the unit is connected, enter device manager and check the active com ports, there should be a device labelled as USB Serial. If no com port is present replace the IF17 and a new device will register.

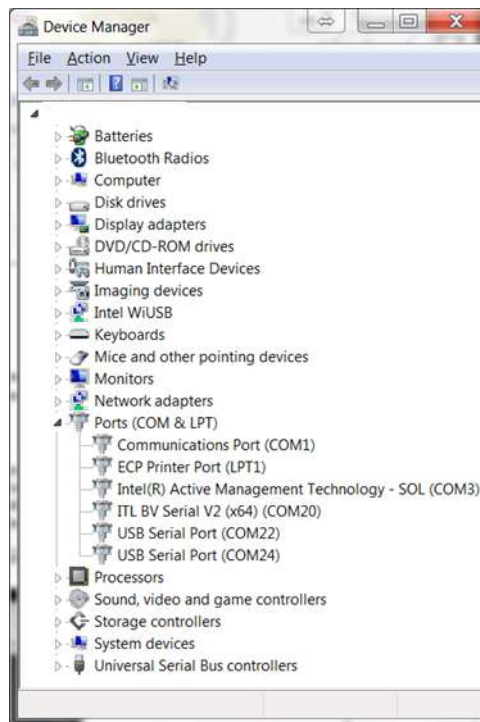

Check the connection to the host software, if there is still an issue replace the IF17 or switch com ports on the PC. If the unit is detected but there is a yellow triangle next to the serial port then the drivers should be reinstalled as explained in [Section 6.2.1](#).

For linux use the dmesg console command as shown below:

```
james@james-VirtualBox ~  
File Edit View Search Terminal Help  
james@james-VirtualBox ~ $ dmesg | grep tty  
[ 0.000000] console [tty0] enabled  
[ 55.387744] usb 1-2: FTDI USB Serial Device converter now attached to ttyUSB0  
james@james-VirtualBox ~ $
```



9 SECOND LEVEL SUPPORT

Essential Tools:

- Relevant TEBS key
- ITL Diagnostic Tools
- Laptop
- USB A to B cable
- Calibration Paper (LB00149)
- IF17, cable and power supply
- 5mm Alan key

9.1 Clearing a Jam within the NV200

9.1.1 Note is in the note path

Open the note path by pulling the top catch forwards as shown below. Carefully pull the note out of the unit. Shut the head, the unit will reinitialise indicating the jam has been removed.

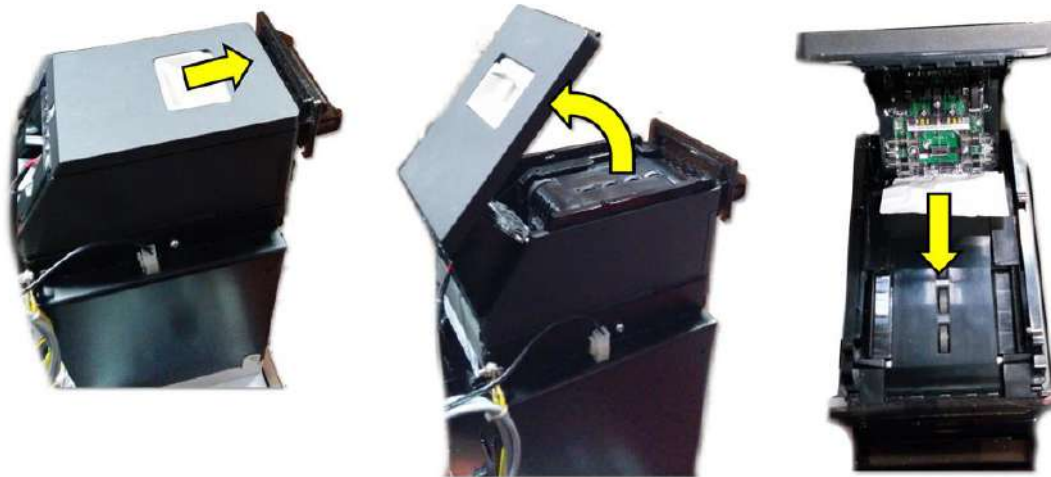

9.1.2 Note is visible once the NV200 has been removed

Disconnect power and remove the NV200 head, by lifting the silver catch below the bezel and pull the validator forwards, when out of position the validator can be lifted off the cashbox. This jam can be cleared by winding the drive gears on the left of the unit and slowly pulling the note out. Replace the NV200 head and reconnect the power.

[<< Back to Contents](#)

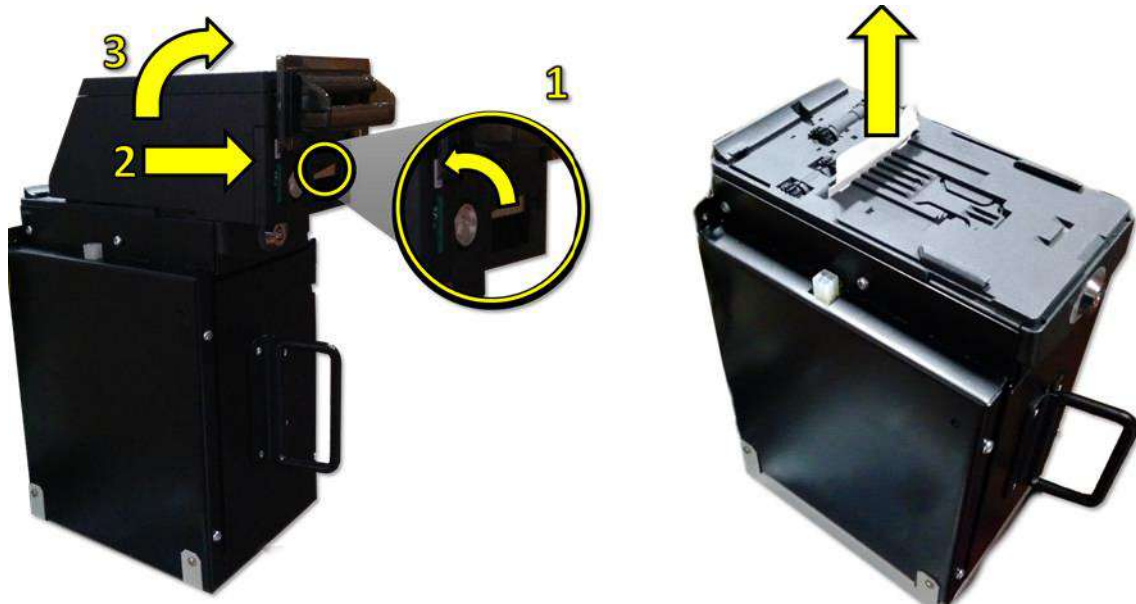

9.1.3 Note isn't visible once the NV200 has been removed

If the note isn't visible when the head is removed the jam is in the cashbox.

To clear a jam in the cashbox follow the relevant cashbox explanation below.

9.1.3.1 Clearing a Jam from the Standard Cashbox

When no note is visible simply remove the cashbox as explained in [Section 4.3.1](#), then open the cashbox. Remove any visible jammed notes or debris, if no debris is visible then move the stacker plate back, this will reveal the note drive mechanism any jammed note should now be visible. Remove the jammed note taking care not to leave any debris inside the unit. Once you believe the jam has been cleared close the cashbox and reinsert the cashbox into the NV200 chassis. The unit should now restart.

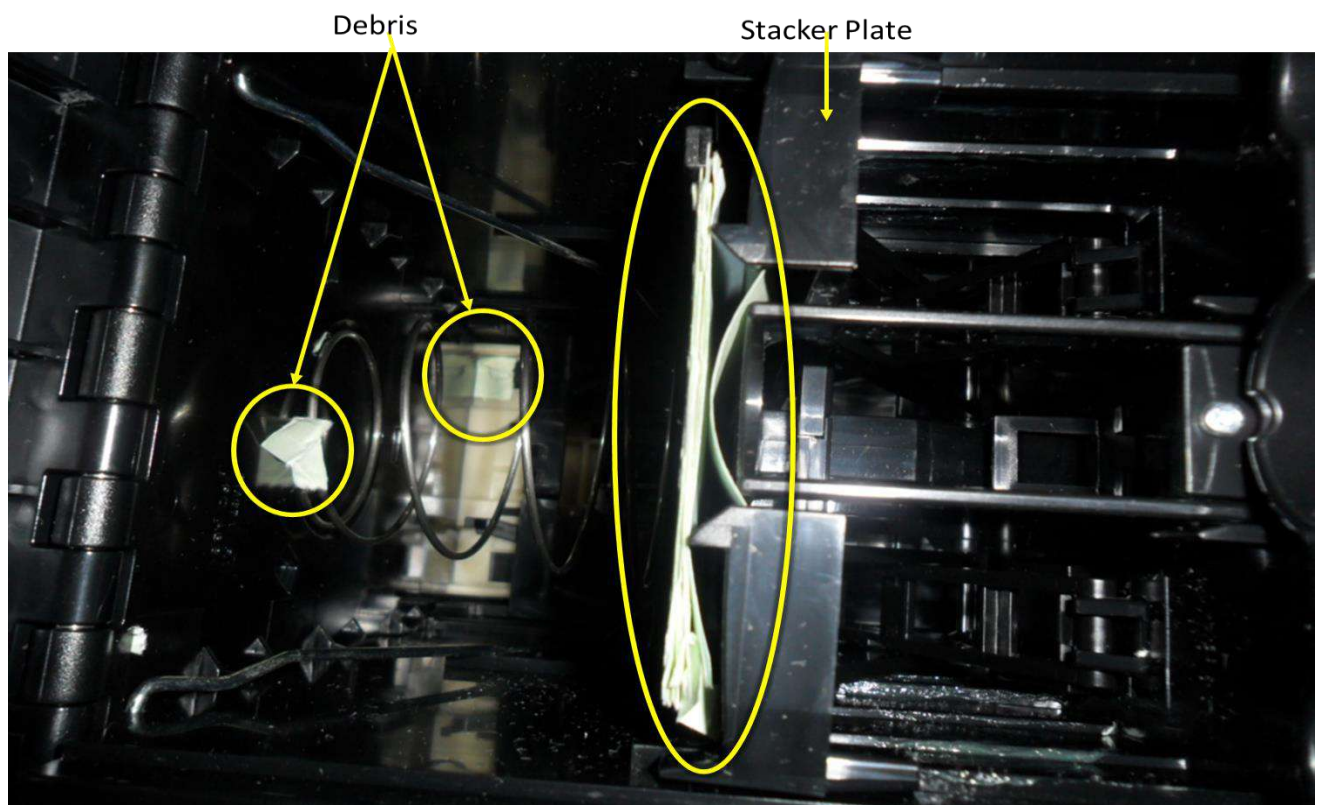

9.1.3.2 Clearing a Jam from the TEBS Cashbox

Ensure the TEBS is connected to power and remove the cashbox.

When the bag is removed, the note causing the jam condition hasn't been credited so will need to be re-inserted when the unit is back in service.

The note causing the jam will be visible; typically the note will be resting on top of the pusher plate and may be folded or torn. It can be behind the push plate.

Once the note has been identified, push the doors back and slowly pull the note out of the TEBS cashbox ensuring there is no debris left behind.

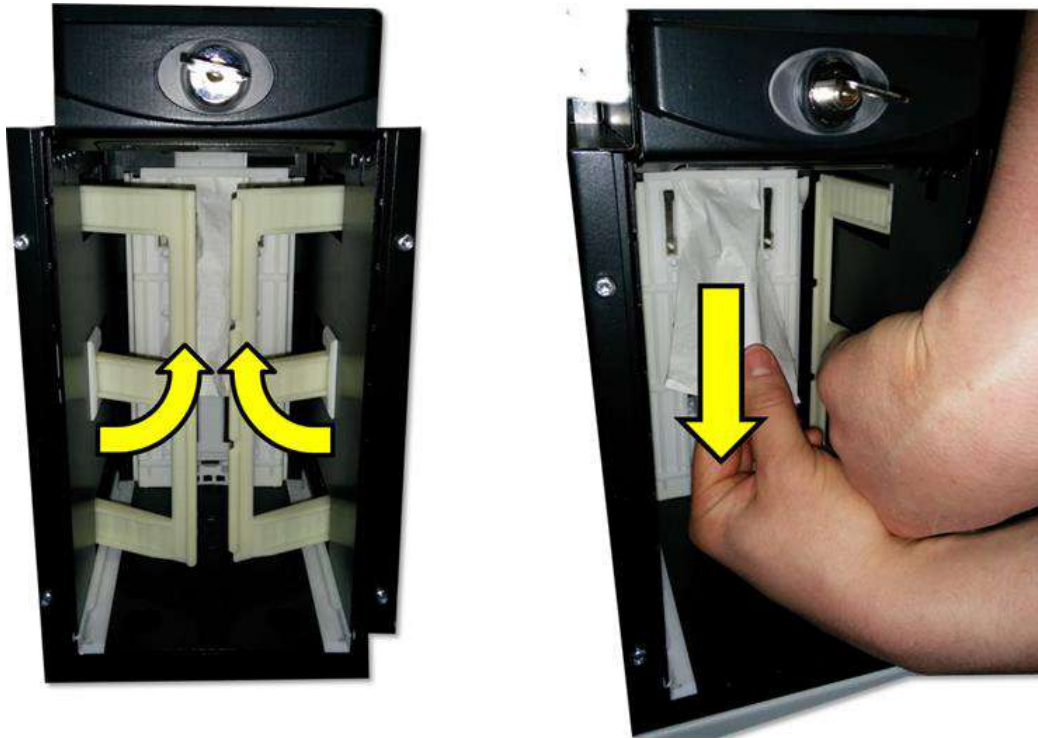

If the note is behind the stacker plate, it is still possible to recover the unit. Wind the stacker plate forward using the gears on top of the TEBS unit as highlighted below. Hold the gear in position while removing the note.

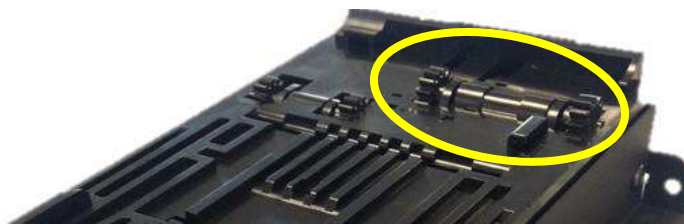

The stacker plate should sit approximately 5cm from the home position. Carefully pull the note out from behind the stacker plate and wind the plate back to its rest position.

Inspect the note when it is removed, should the note have a tear or have a piece missing it could be lodged within the unit and trigger another error. One way of checking for this is to shine a torch into the TEBS cashbox and carefully inspect the surround. Highlighted below is an example of paper located in the top of the TEBS

[<< Back to Contents](#)

unit, this is evident due to the white reflection on the right when compared to the left. Paper may also get stuck behind the belts if the note is forcibly removed.

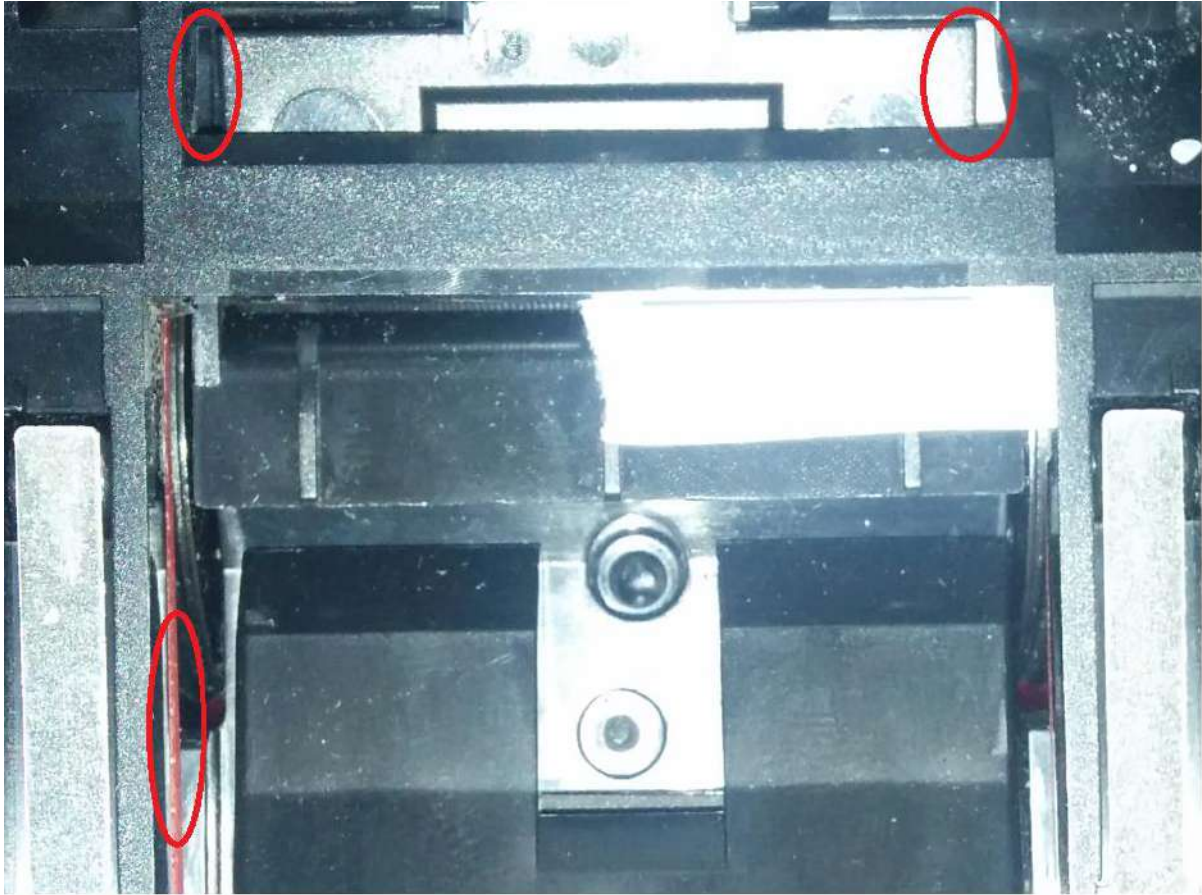

9.2 Clearing a Jam from the Payout Module

In case of a Jam in a payout notes can be manually paid out. The Payout will need to be removed from the NV200 by lifting the silver catch at the front of the NV200 and sliding it away from the cashbox, it is now possible to lift the payout module away. The only tool required to carry out this process is a 5 mm Allen key.



Caution!

Risk of serious damage to payout module internal mechanism

Take great care not to overwind the mechanism or force past the dead stops – if done the payout unit will be damaged beyond repair.



Caution!

Do not use a power tool to unwind the unit this will permanently damage the unit.



NV200 Family User Manual

[<< Back to Contents](#)

1. Locate the Allen key into the hexagonal Diverter slot.

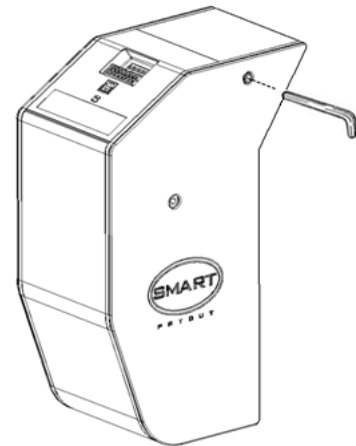

2. Move the Diverter into the transfer position by gently turning the Allen key anti-clockwise until it reaches the dead stop.

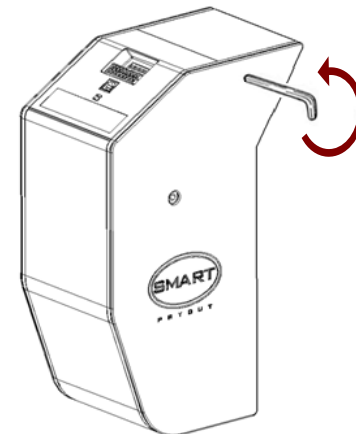

3. Locate the Allen key into the hexagonal Motor Drum slot.

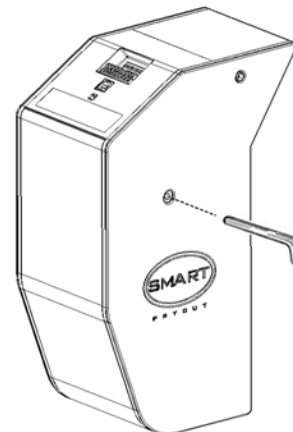

4. Transfer all the stored bank notes onto the Transaction Drum by turning the Allen key clockwise. The barcode will be travelling towards the note exit and the bank notes will be travelling into the module.

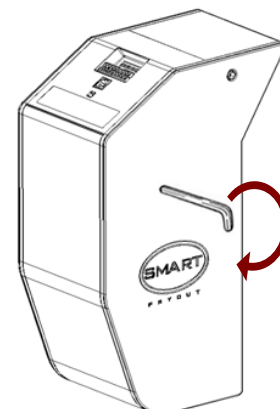

NV200 Family User Manual

[<< Back to Contents](#)

5. Once all the bank notes have been transferred to the Transaction Drum move the Diverter into the payout position by gently turning the Allen key clockwise until it reaches the dead stop.

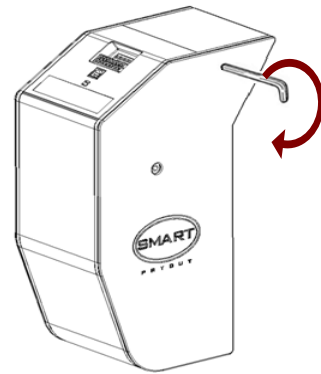

6. Pay out the stored bank notes by turning the Allen key anti-clockwise. The barcode will be travelling into the Payout module and the bank notes will be paid out through the note exit.

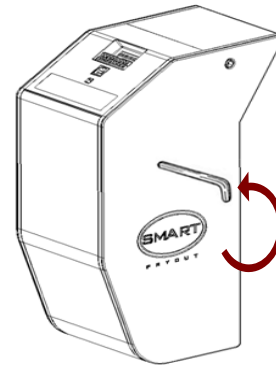

[<< Back to Contents](#)

9.3 Diverter and Tape positions in the Payout Module

The images below show the barcode tape position with the diverter in the open and closed positions.

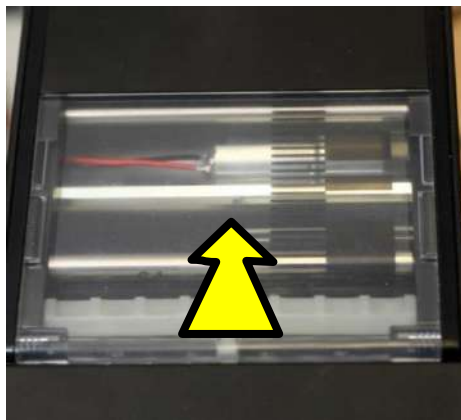

Normal tape position – diverter in CLOSED



Normal tape position – diverter in OPEN position

9.4 Clearing a Jam from the Ticket Module

If a Jam has occurred in the SMART Ticket Power must be Removed, once removed disconnect the NV200 by lifting the silver catch at the front of the NV200 and sliding it away from the cashbox, it is now possible to lift the Ticket module away.

With the NV200 removed the Ticket Path can be opened as explained in [Section 7.2.4](#).

Remove any visible blockage then remove the loaded tickets.

Ensure there is no debris built up in the SMART Ticket as explained in [Section 7.2.4](#).

Attach the NV200 and power. insert the paper once the unit has started up.

9.5 Diagnostic Tools

Diagnostic tools is a piece of software provided to help identify the root cause of the issue being seen with units, the software connects to the unit and enables the user to independently run certain aspects of the unit. A link to diagnostic tools and the



NV200 Family User Manual

[<< Back to Contents](#)

required files can be obtained from our support team. Please note diagnostics can only be carried out with an IF17, direct USB connection is not supported.

An init file is required to re-initialise the sensors, this must be placed in the install directory of Diagnostic Tools and a new file must be obtained from Support periodically.

Open the software, then navigate to the options tab. This will allow you to select the appropriate port.

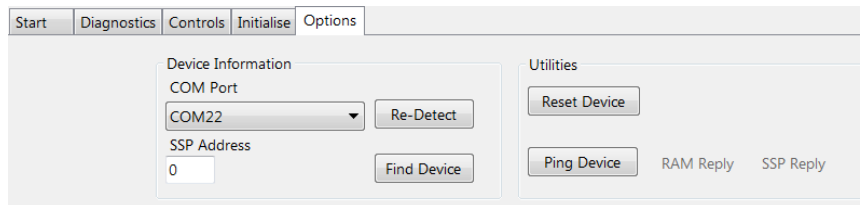

9.5.1 Running unit diagnostics

The diagnostic tab runs a comprehensive set of tests on the unit to detect issues ranging from sensors to mechanical drive issues. To test simply navigate to the tab and click 'Begin Testing' this will obtain information from the unit before running a series of automated tests. Should any fail contact your local repair centre.

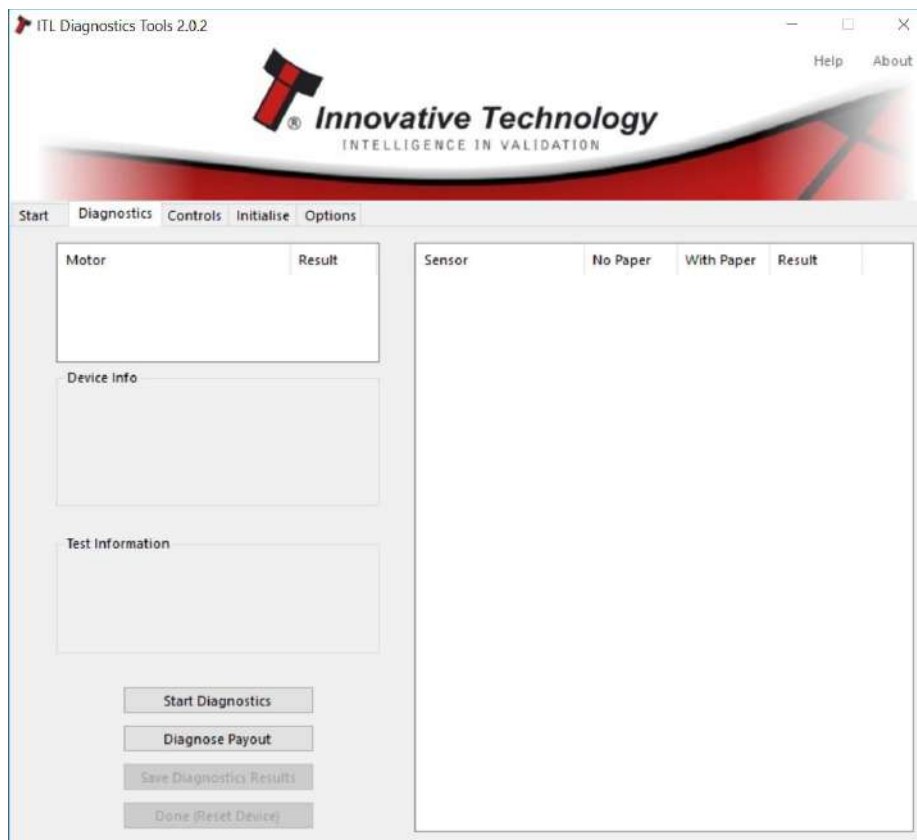

9.5.2 Testing the mechanical operation

The Controls tab allows the user to manually run the drive motors on the NV200 and map the sensor response to the actions, this can help identify the root cause of the issue.



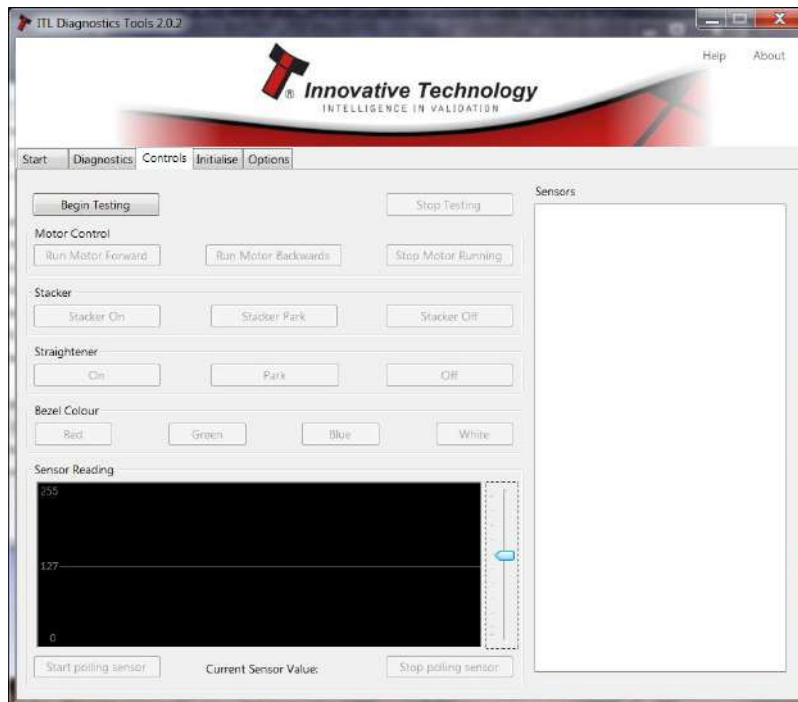

Click 'Begin Testing', this will initiate a scan of the unit to detect the appropriate settings. Once the unit type has been detected the buttons will be populated, click on the appropriate mechanism which needs to be tested.

9.5.3 Re-initialisation of the sensors

Should the NV200 be displaying unit not initialised (as explained in [Section 8.1](#)), or the unit is showing some degradation in acceptance which the cleaning routines outlined in [Section 7.2](#) then it may be necessary to re-initialise the sensors on the NV200, this is possible through diagnostic tools.

Navigate to the Initialise tab, click 'Initialise' the motors will activate, when you hear the drive motor running continuously then insert the green calibration card. You will now see the sensors calibrate. When complete a prompt will tell you the sensors had been calibrated. Should you have any sensors which cannot calibrate contact your local repair centre, a list of which can be found on our website.

[<< Back to Contents](#)



9.6 Testing after an error has been cleared

Once an error has been cleared, ensure the device is tested by inserting bills and paying out notes/tickets where applicable. A recommended test is 10 notes in and 10 notes/tickets out, this will help limit the number of repeat calls for the same issue.



NV200 Family User Manual

[<< Back to Contents](#)

10 APPENDIX

10.1 2D Drawings

10.1.1 NV200

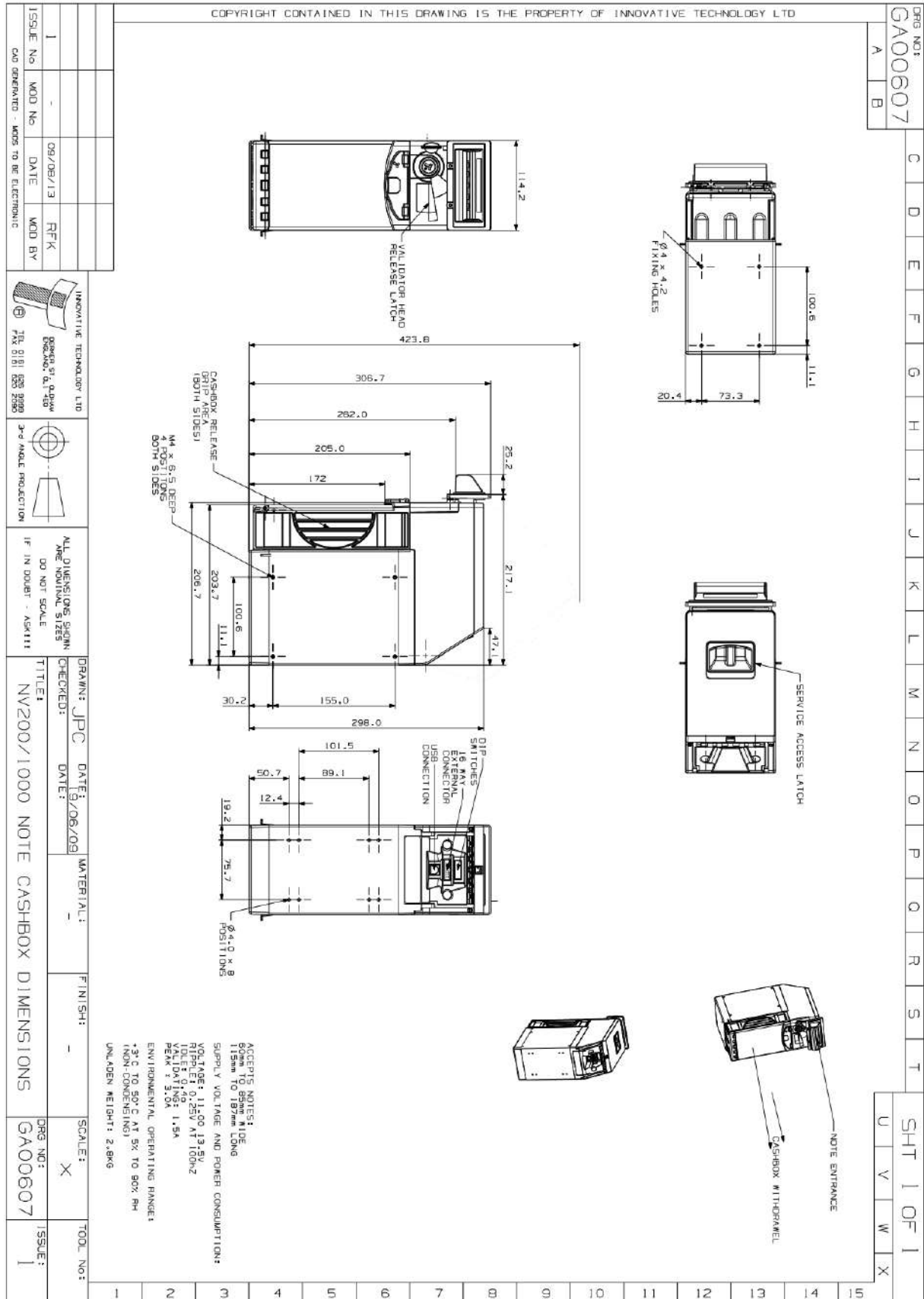

NV200 Family User Manual

[<< Back to Contents](#)

10.1.2 NV200 with Payout module

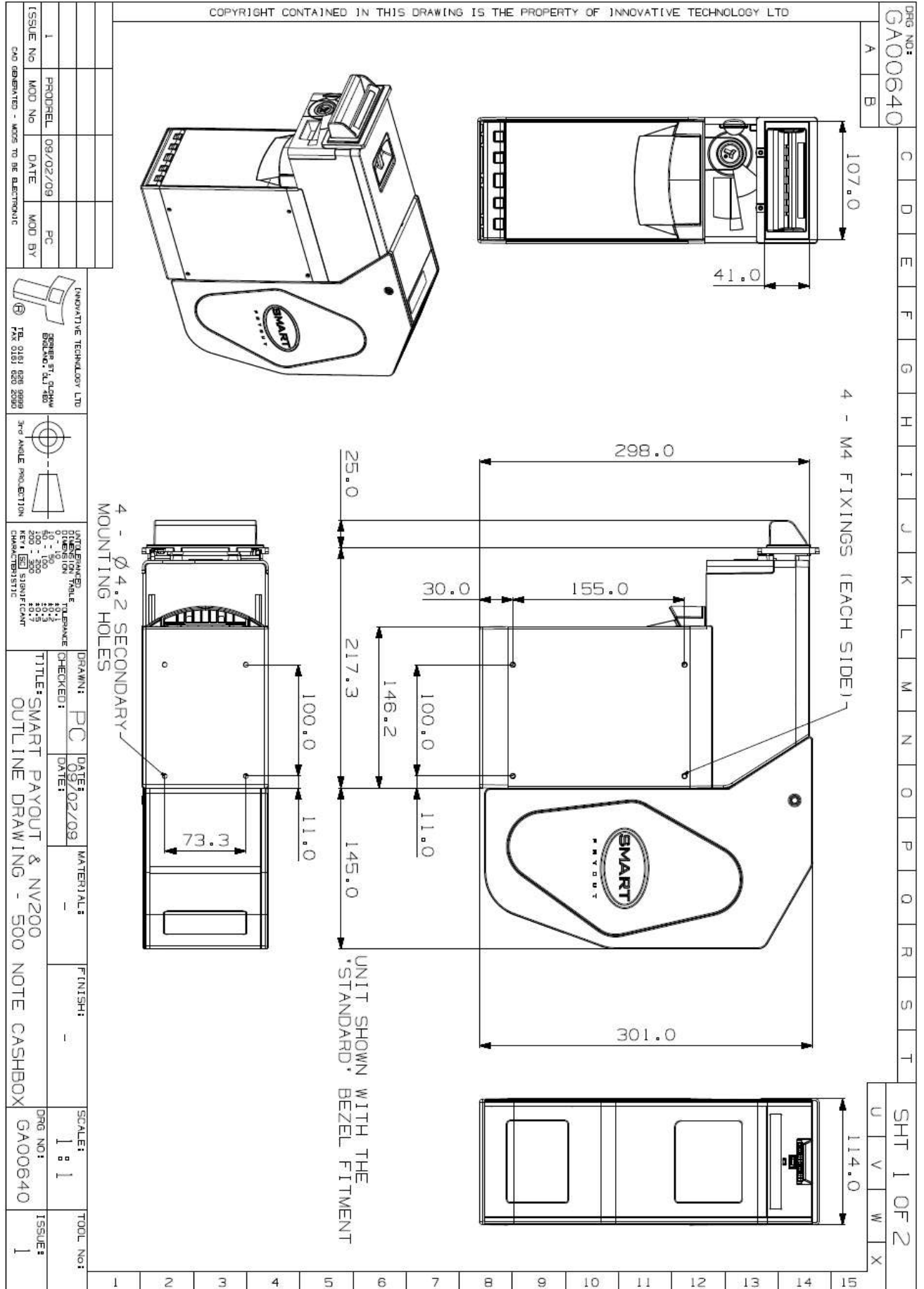

NV200 Family User Manual

[<< Back to Contents](#)

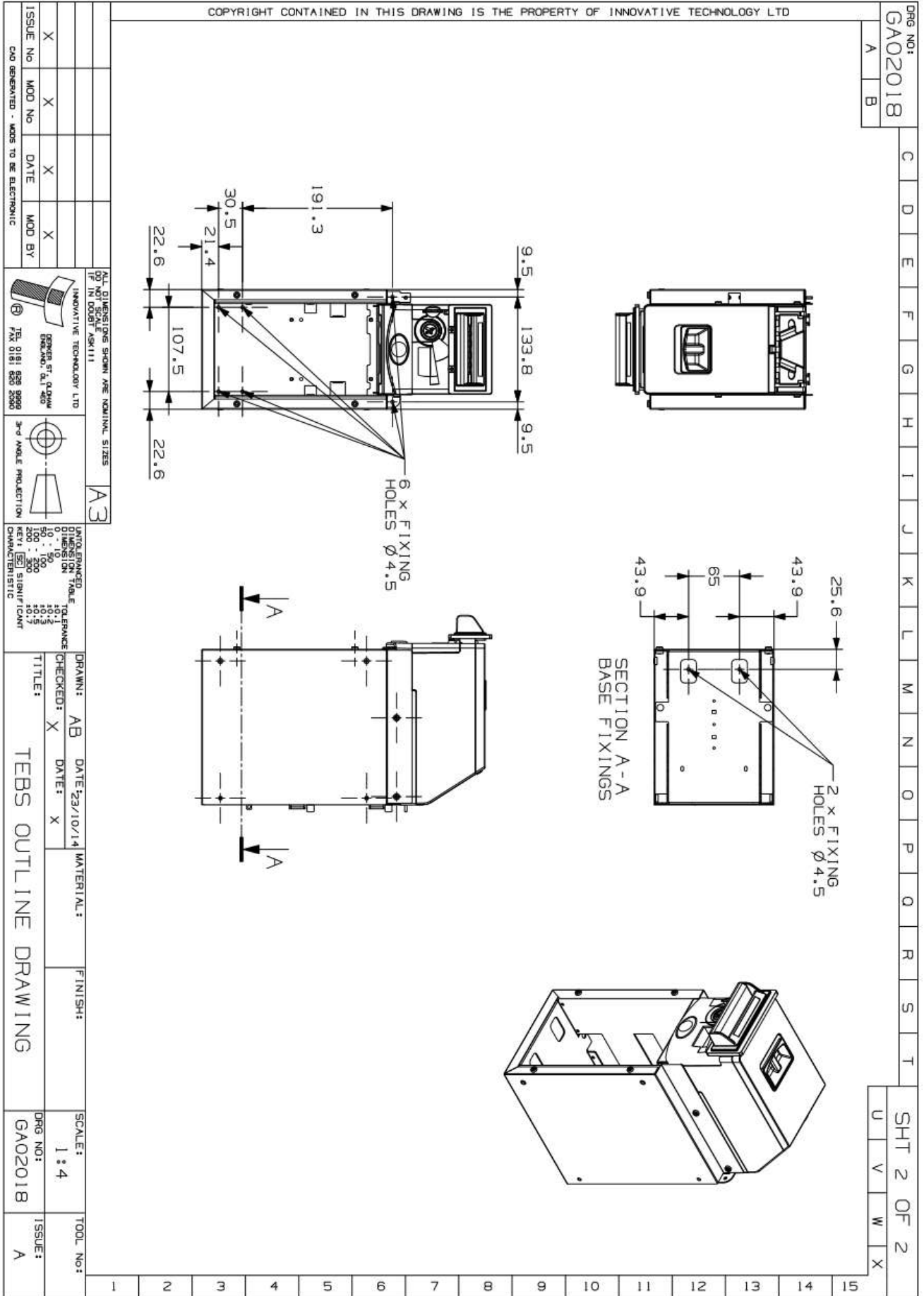

[<< Back to Contents](#)

10.2 Energy Profiles

10.2.1 NV200 Standard Cashbox

10.2.1.1 12 Volts

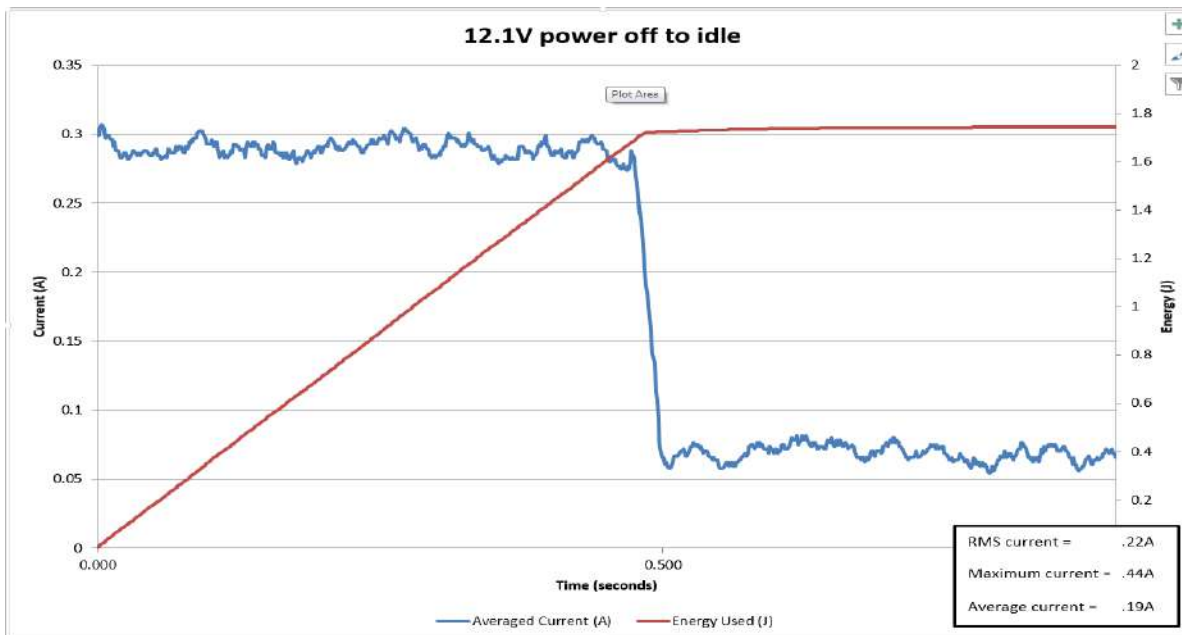
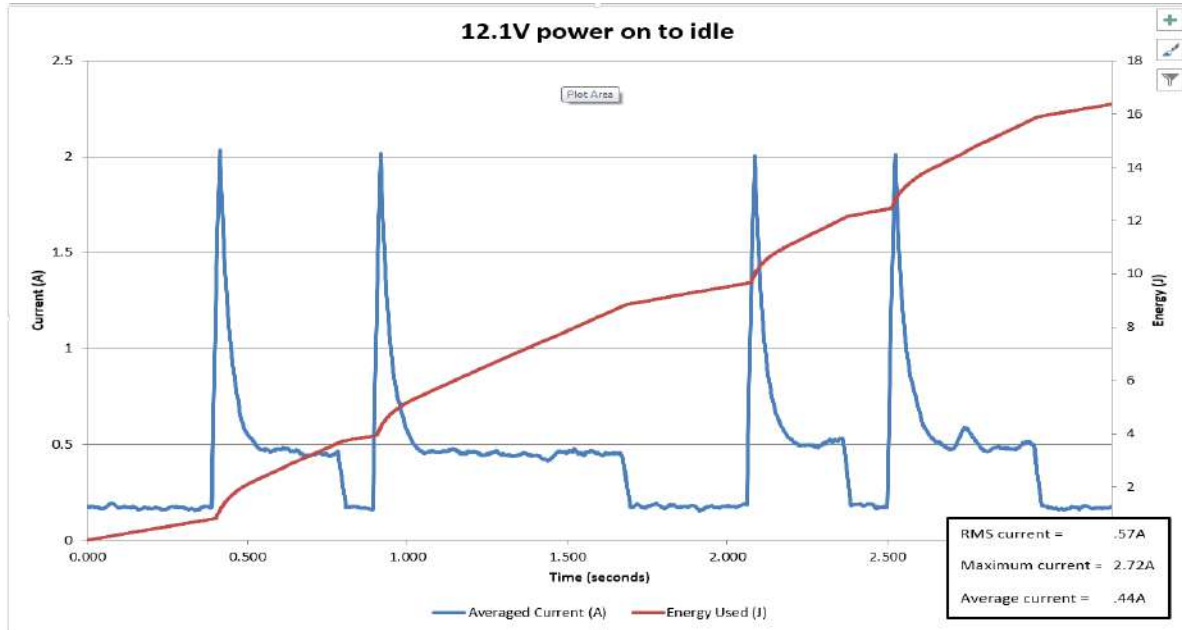

[<< Back to Contents](#)

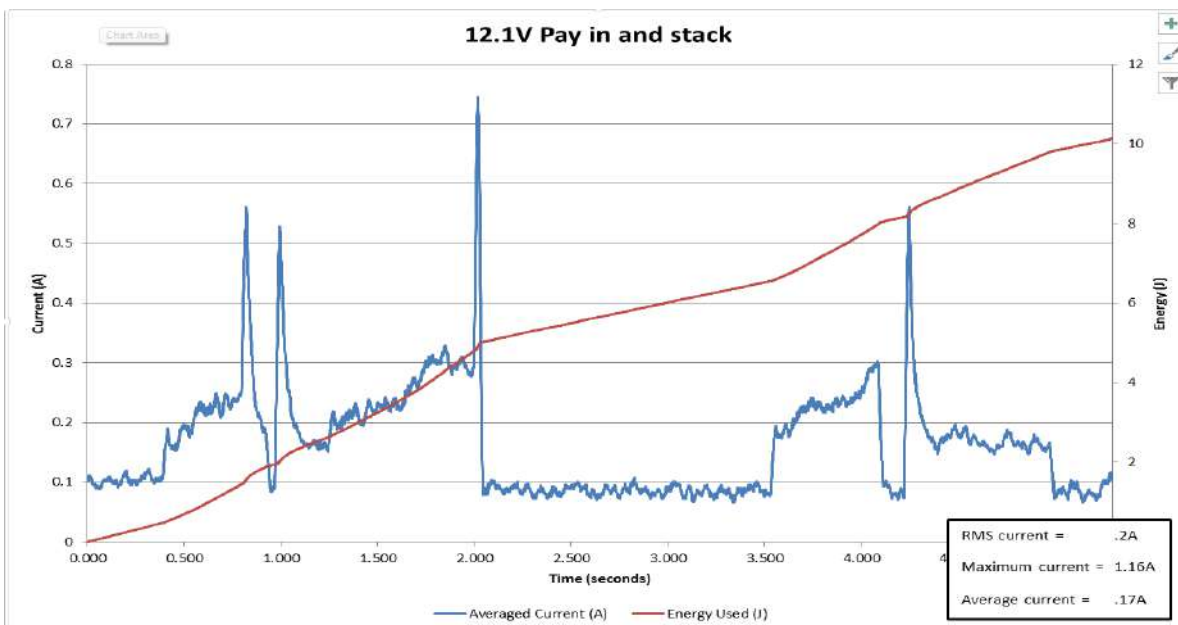
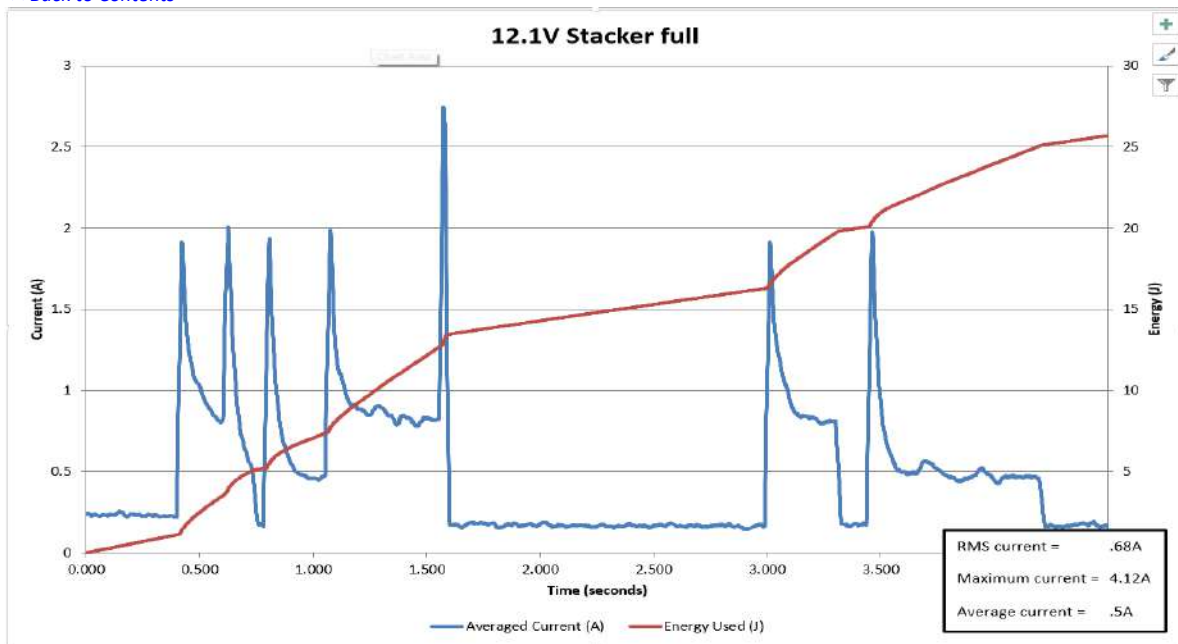

10.2.2 NV200 with Payout Module

10.2.2.1 12 Volts Power off to idle



NV200 Family User Manual

[<< Back to Contents](#)

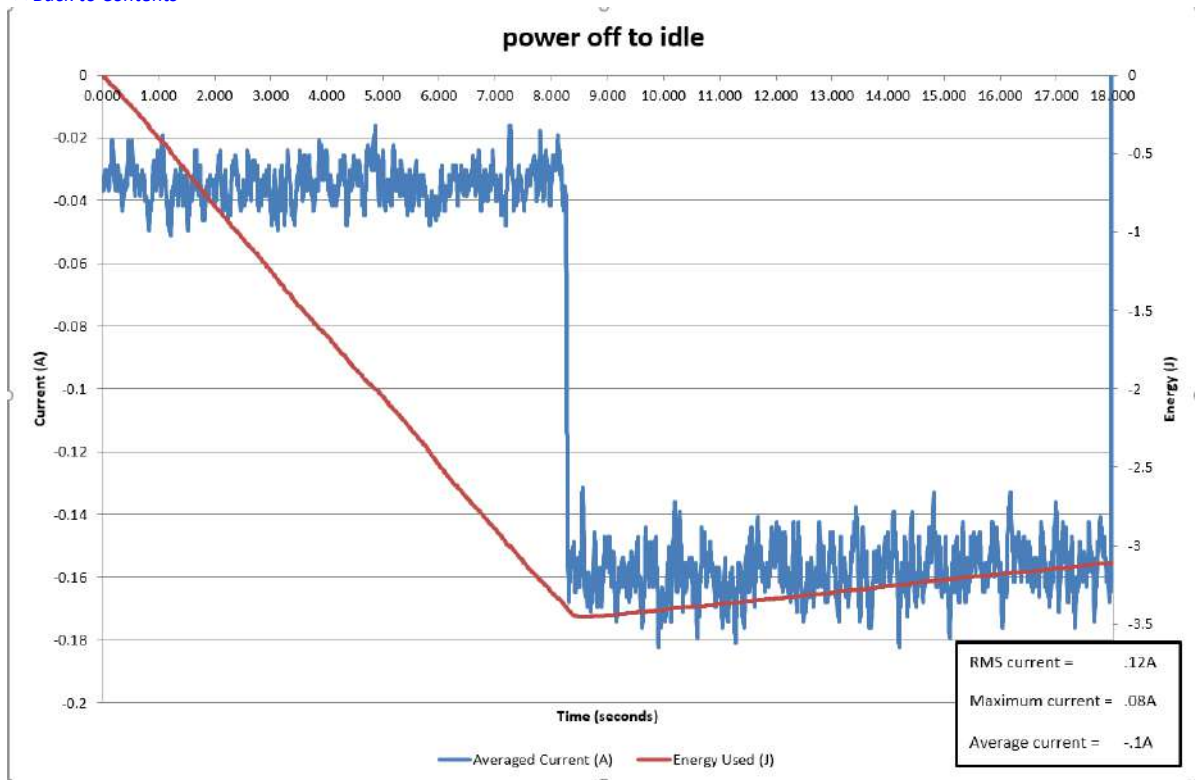

Power on to idle

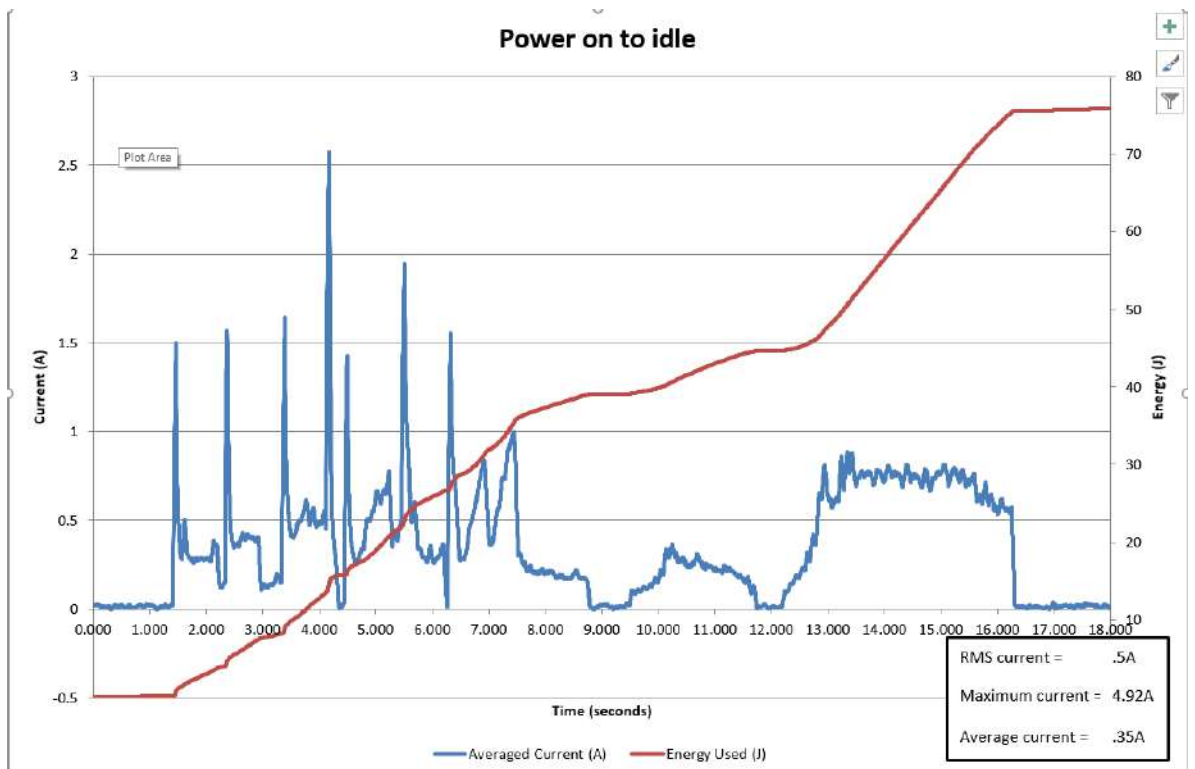

NV200 Family User Manual

[<< Back to Contents](#)

10 second idle

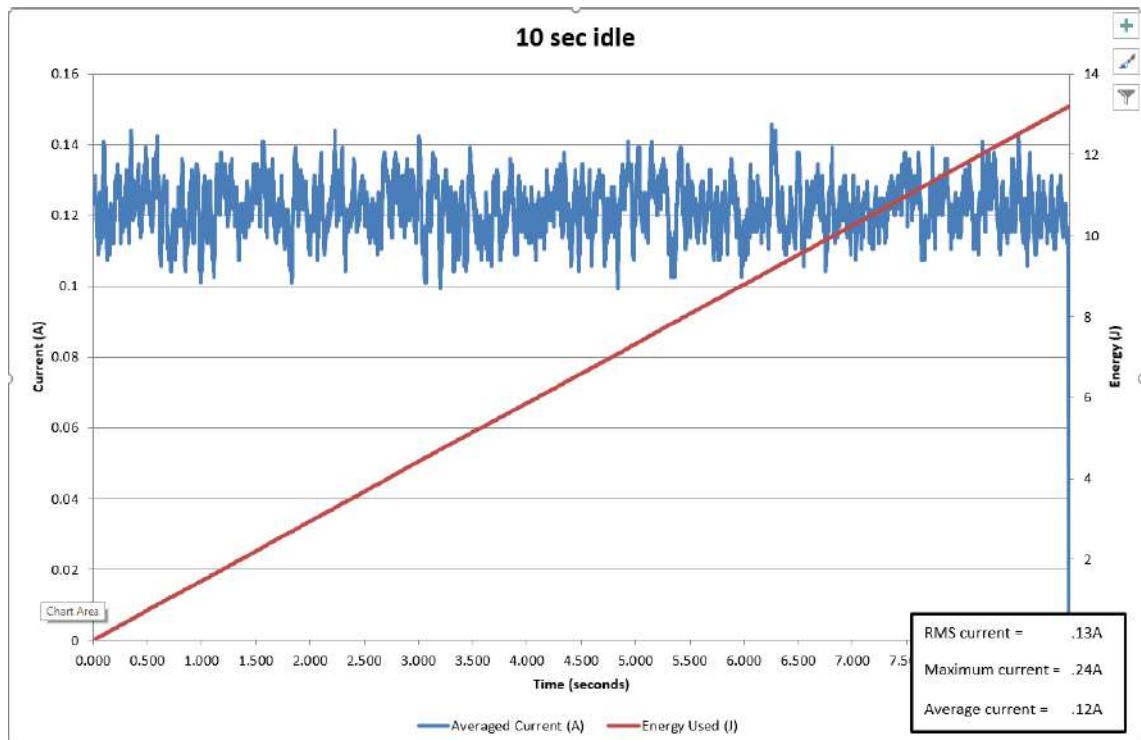

Note insert and stored

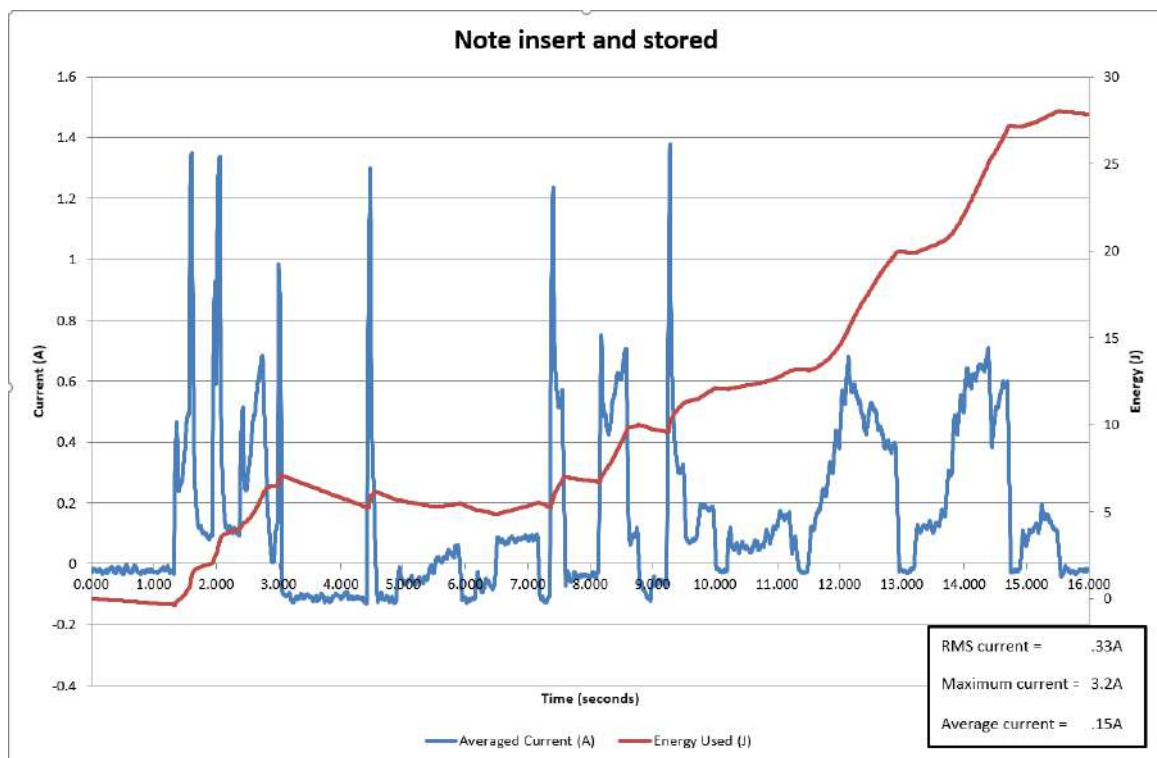

NV200 Family User Manual

[<< Back to Contents](#)

Note insert and reject

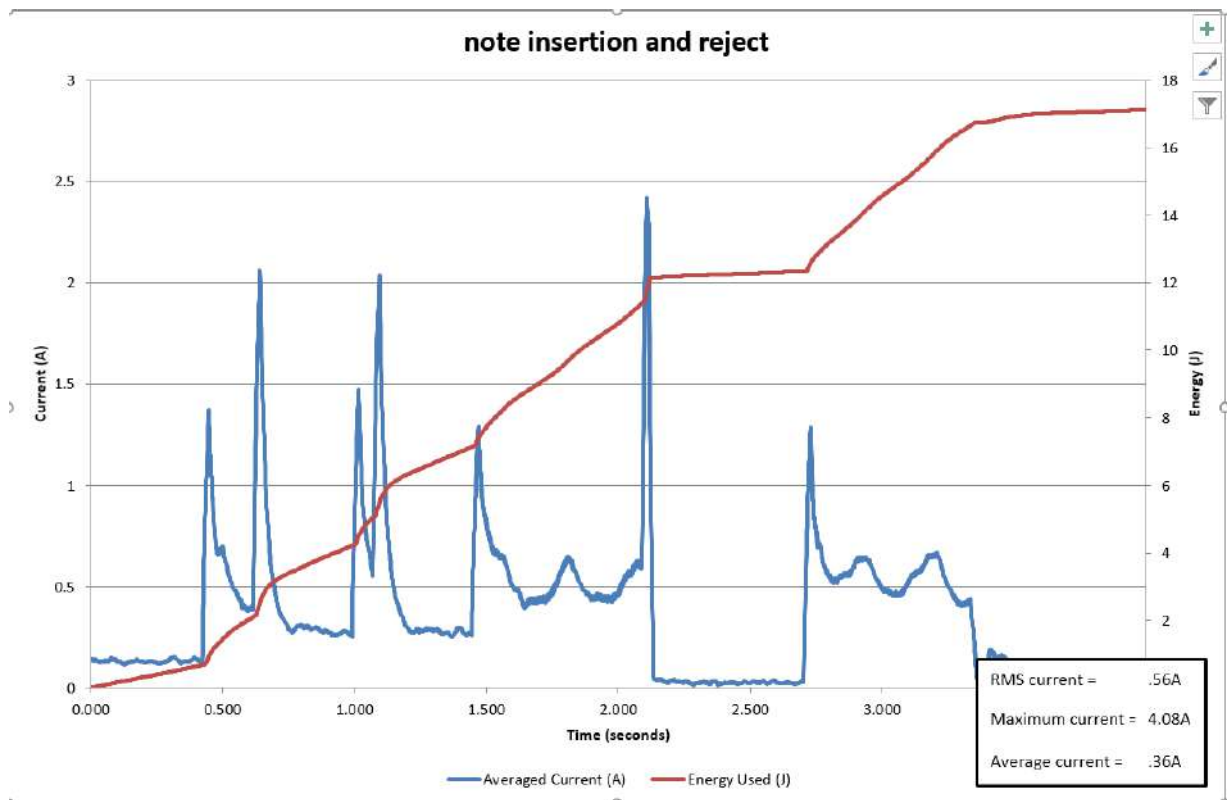

Note paid out

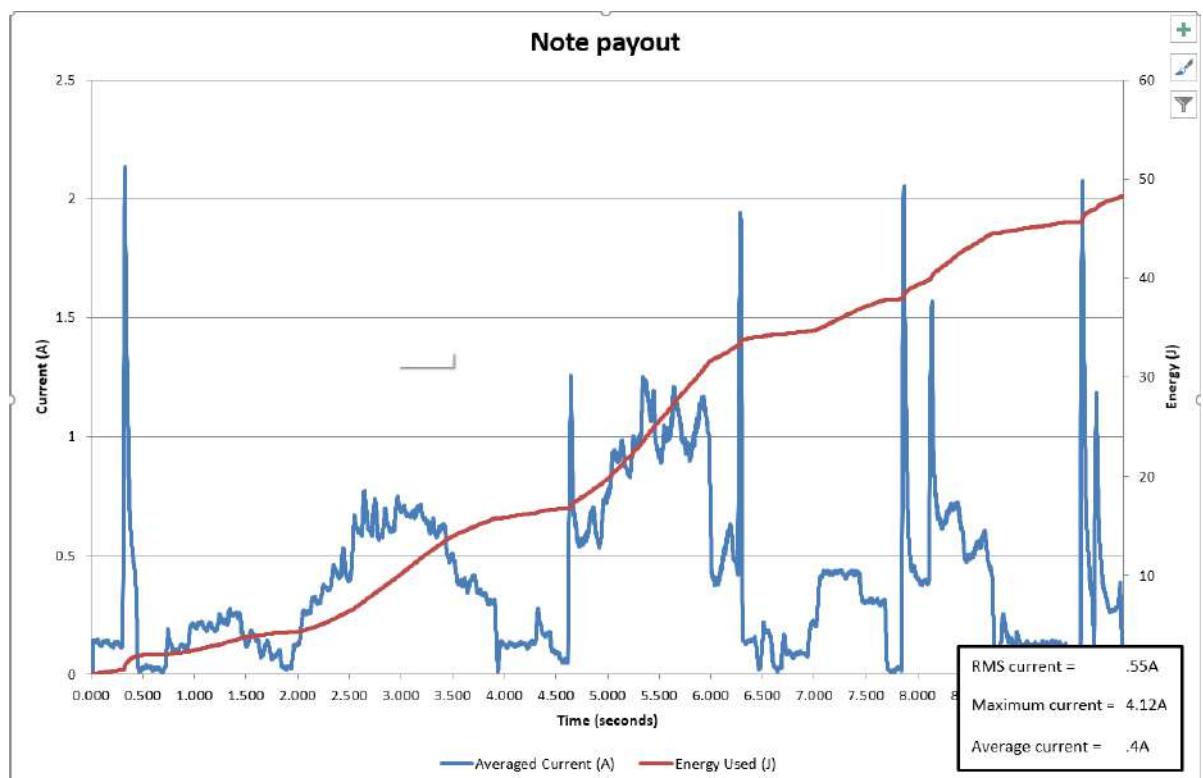

Anti-Jam Routine

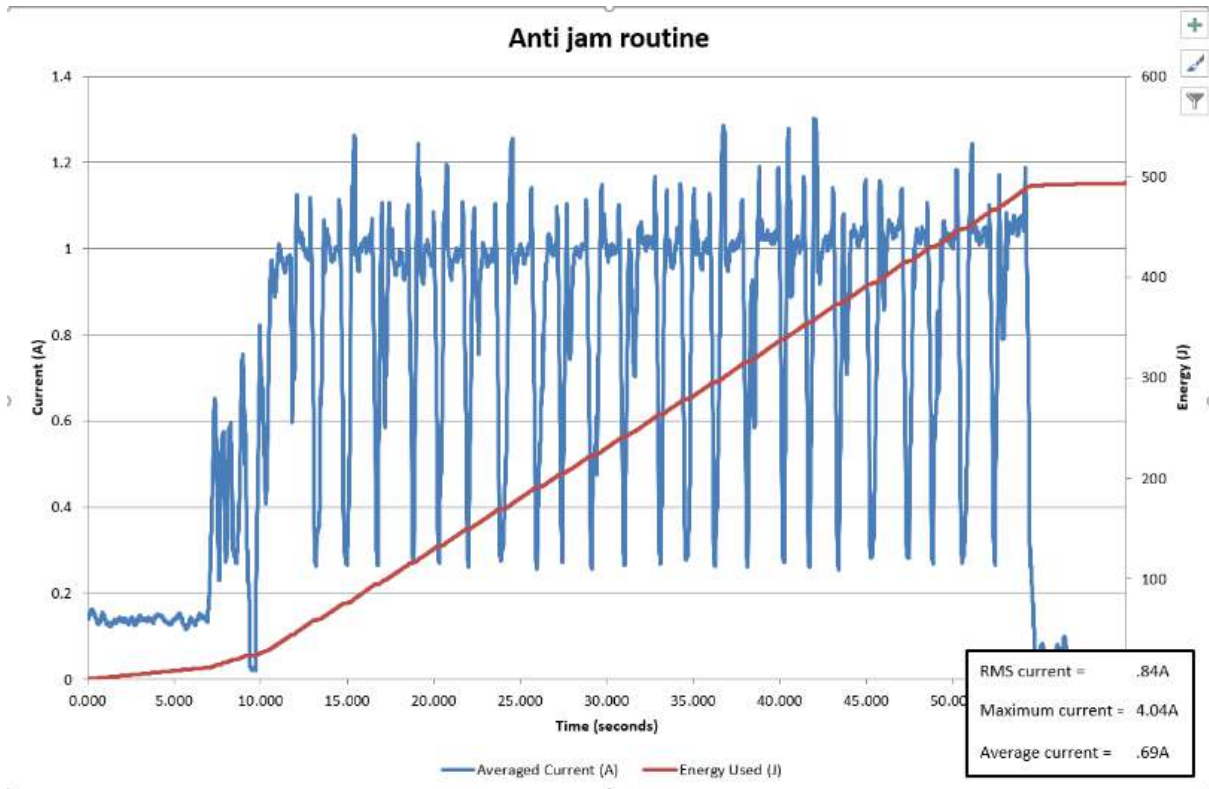

Smart Payout Jam

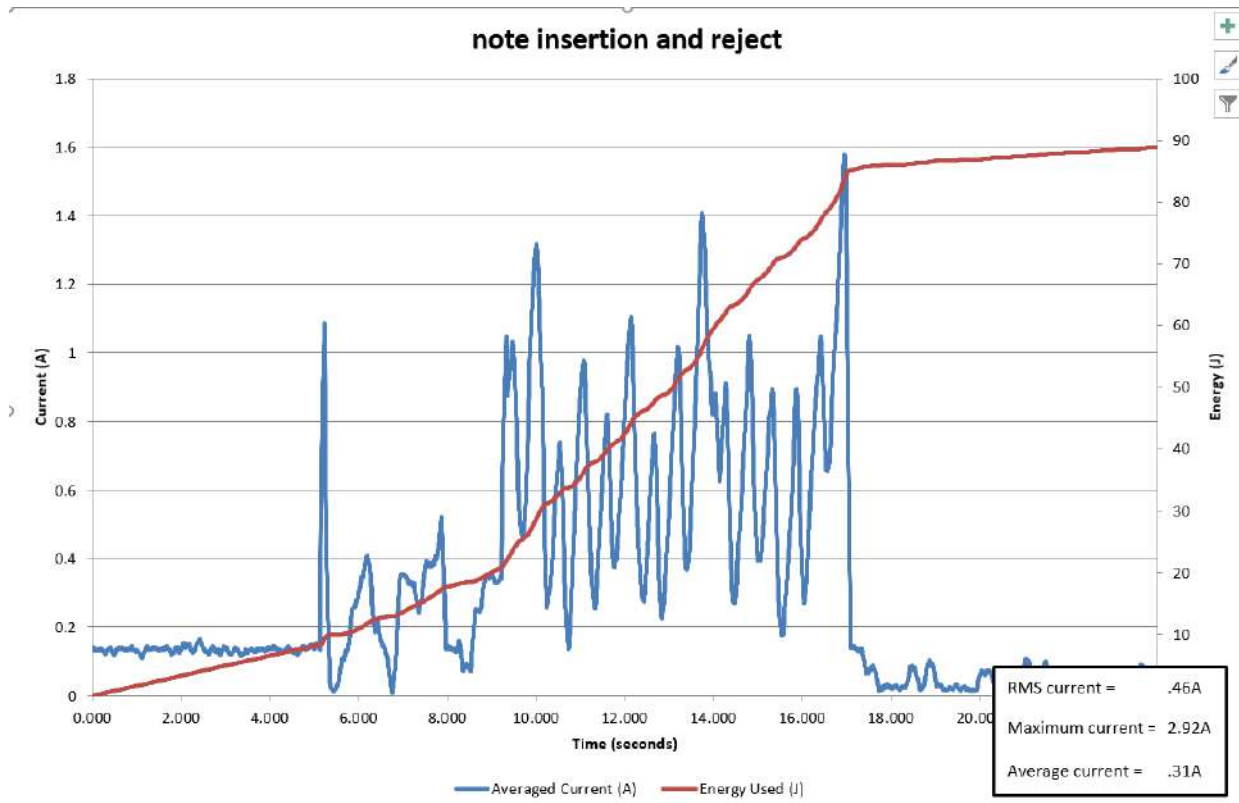

[<< Back to Contents](#)

10.2.2.2 24 Volts

Power off to idle

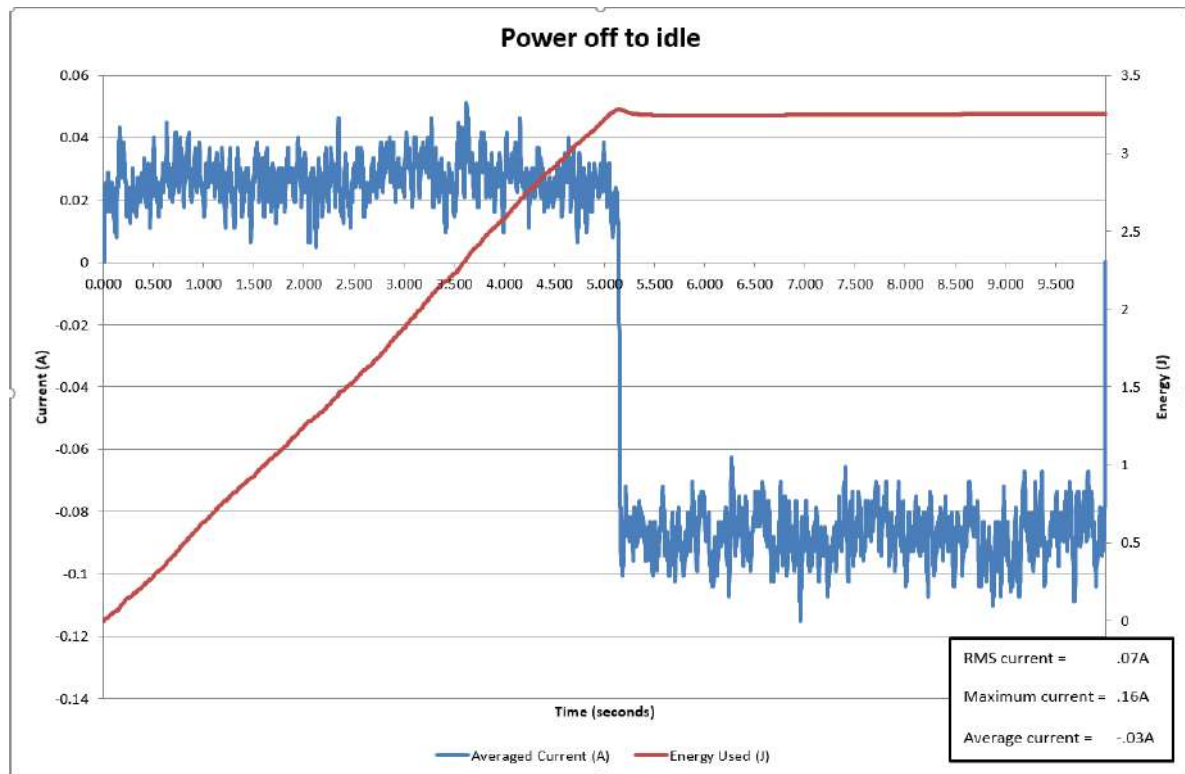

Power on to idle

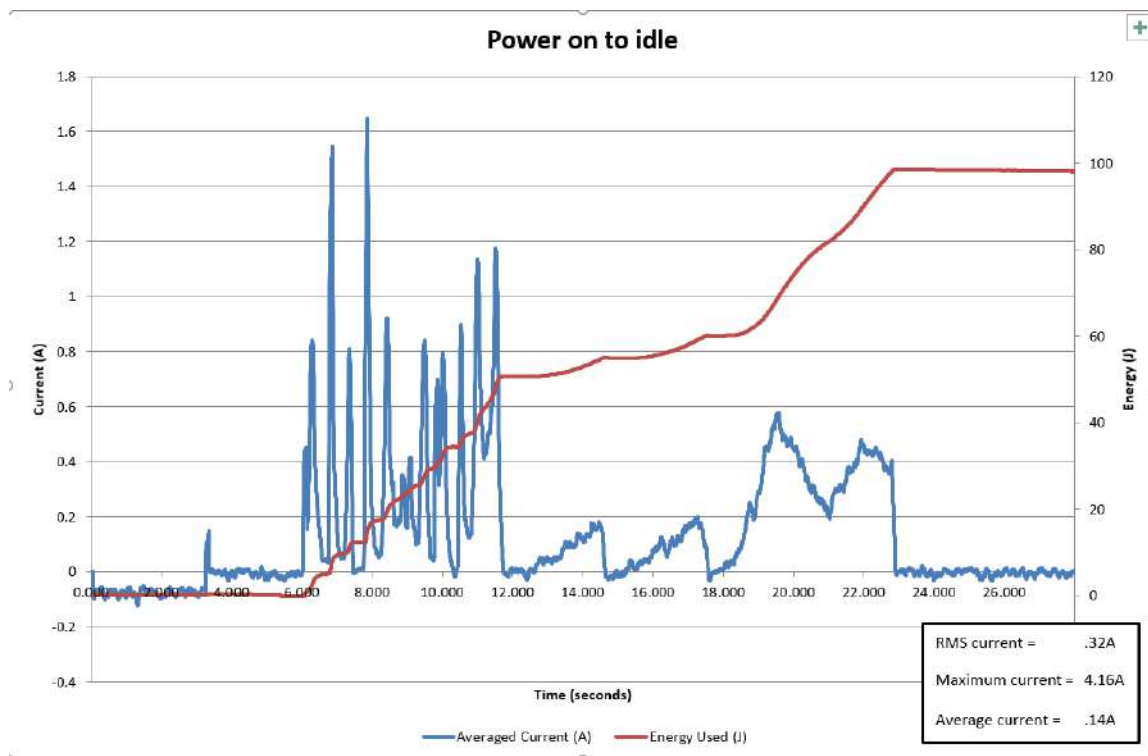

NV200 Family User Manual

[<< Back to Contents](#)

10 sec idle

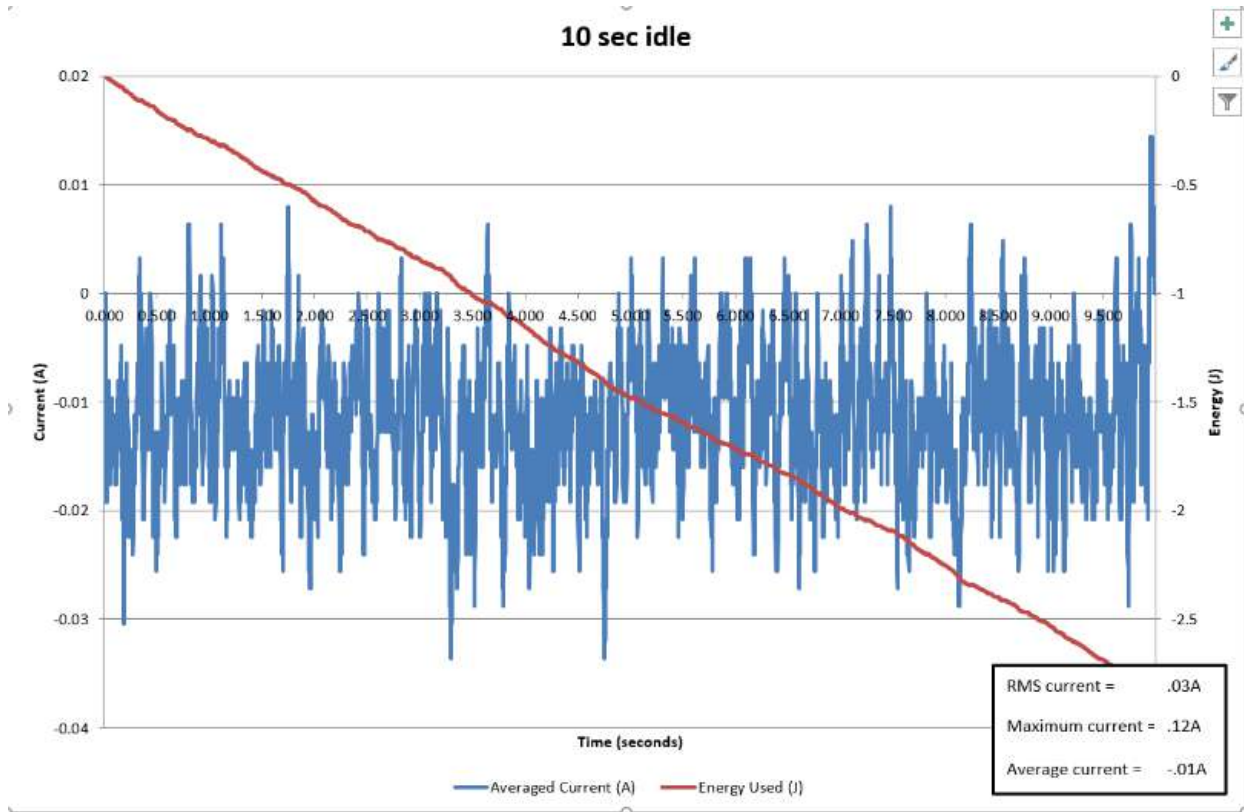

Note insert and stored

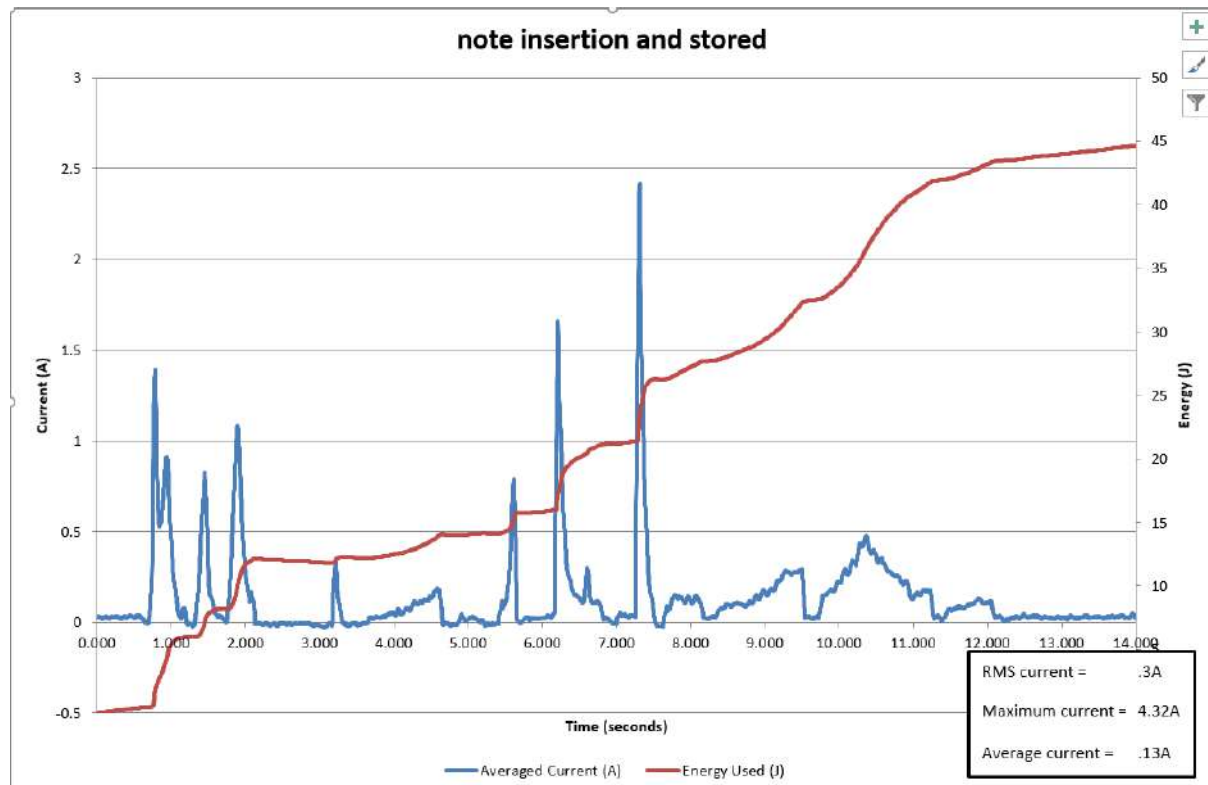

NV200 Family User Manual

[<< Back to Contents](#)

Note insert and reject

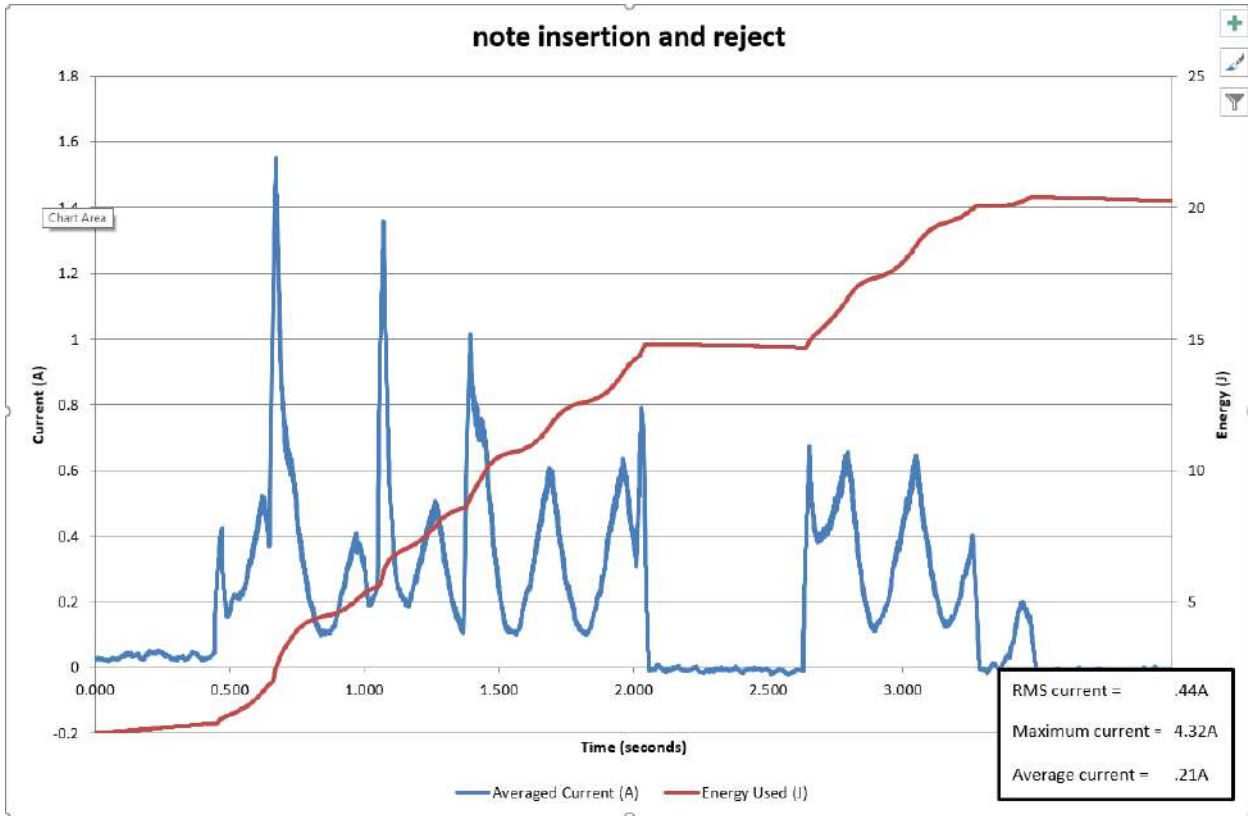

Note paid out

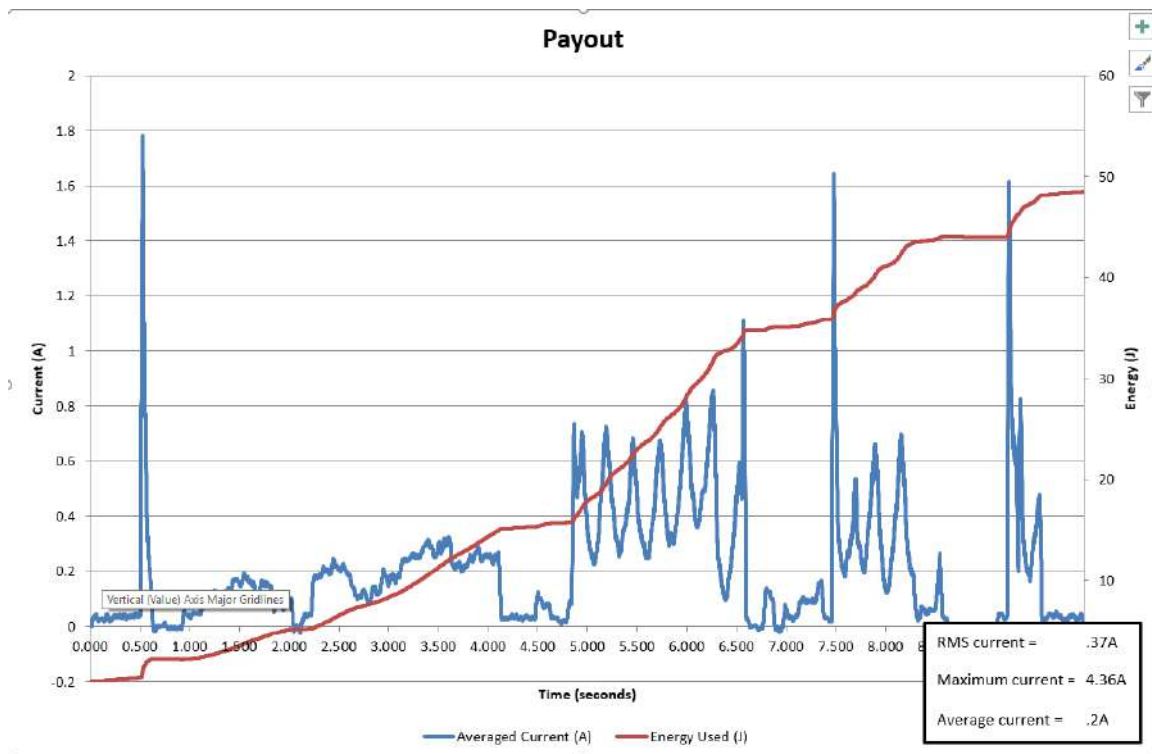

[<< Back to Contents](#)

Anti-Jam Routine

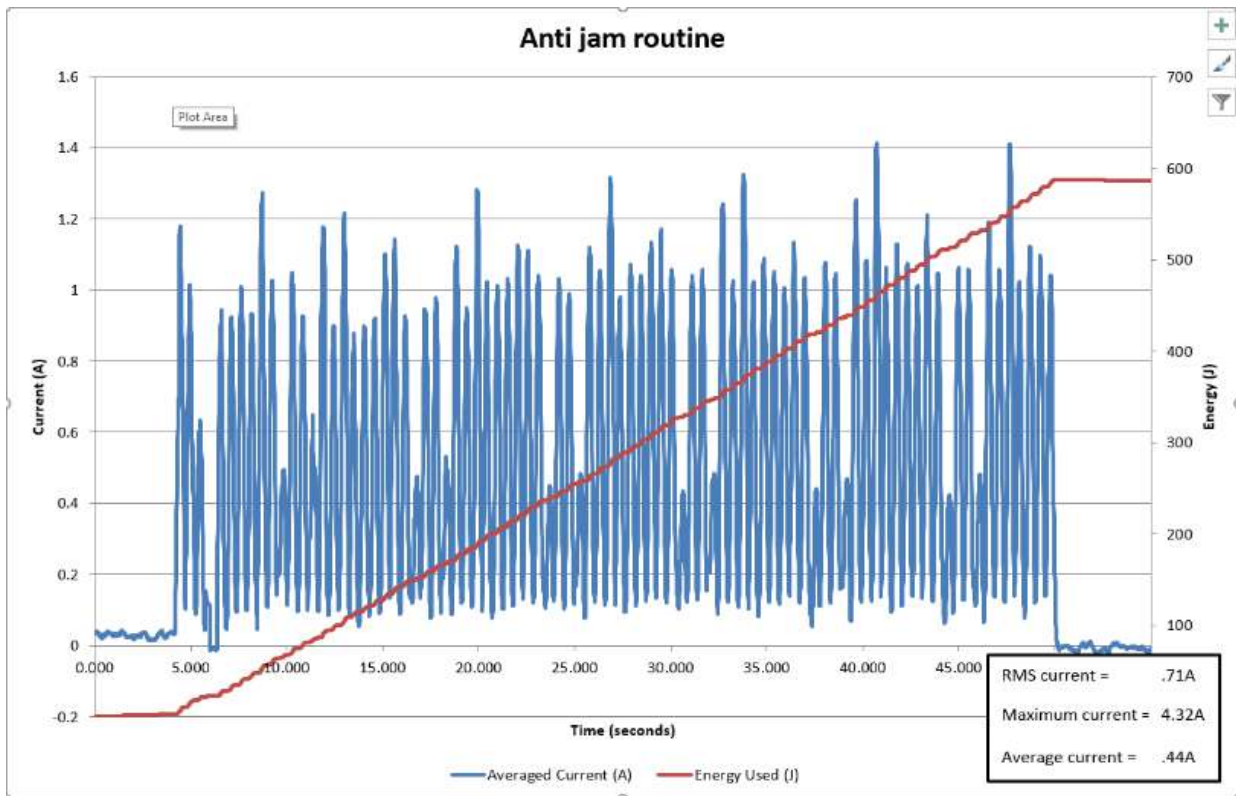

Smart Payout Jam

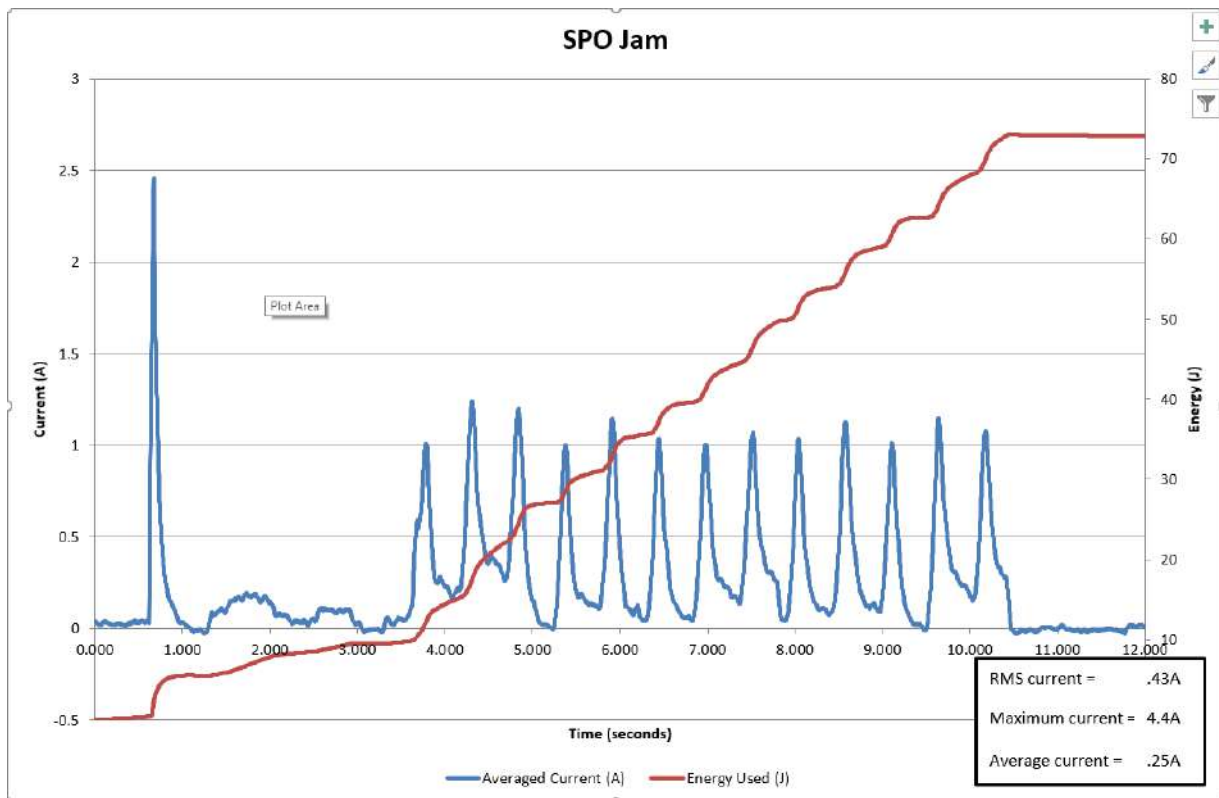

[<< Back to Contents](#)

10.2.3 NV200 with Ticket module

Power off to idle

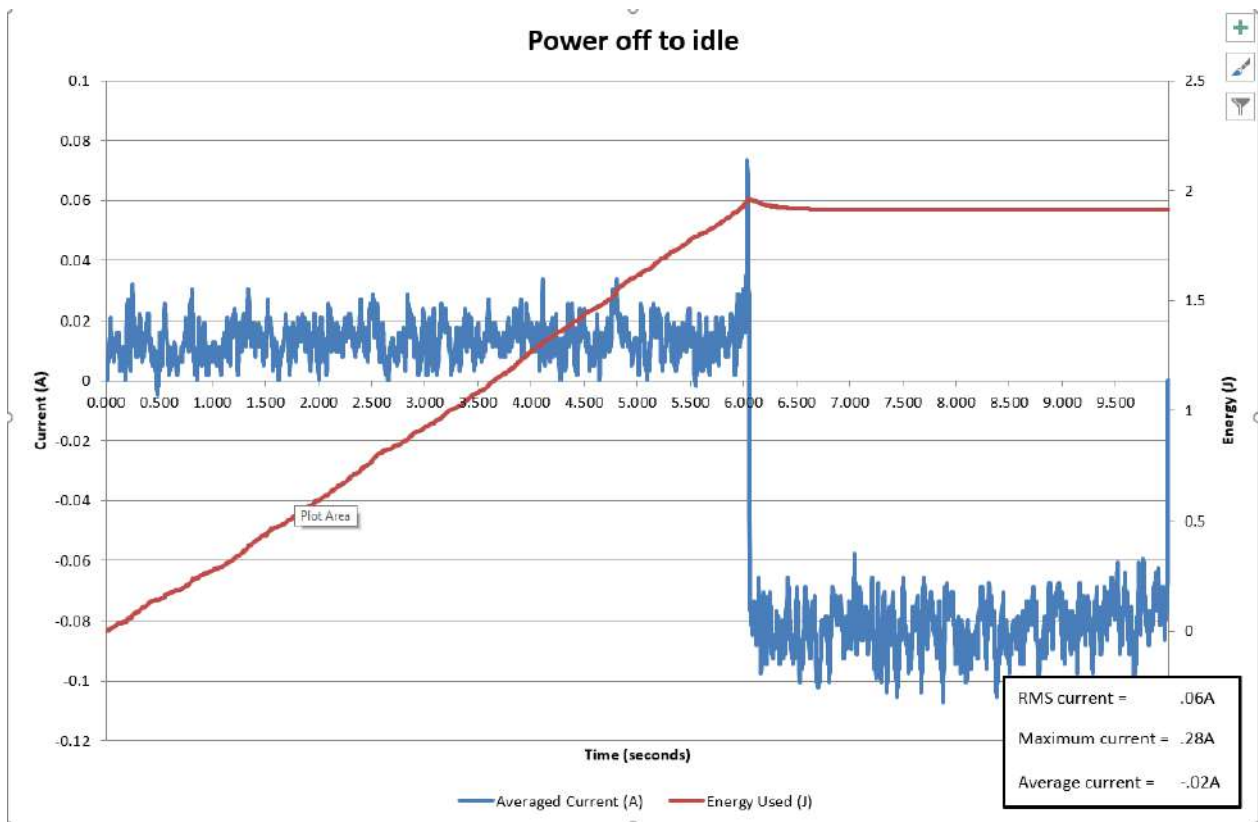

Power on to idle

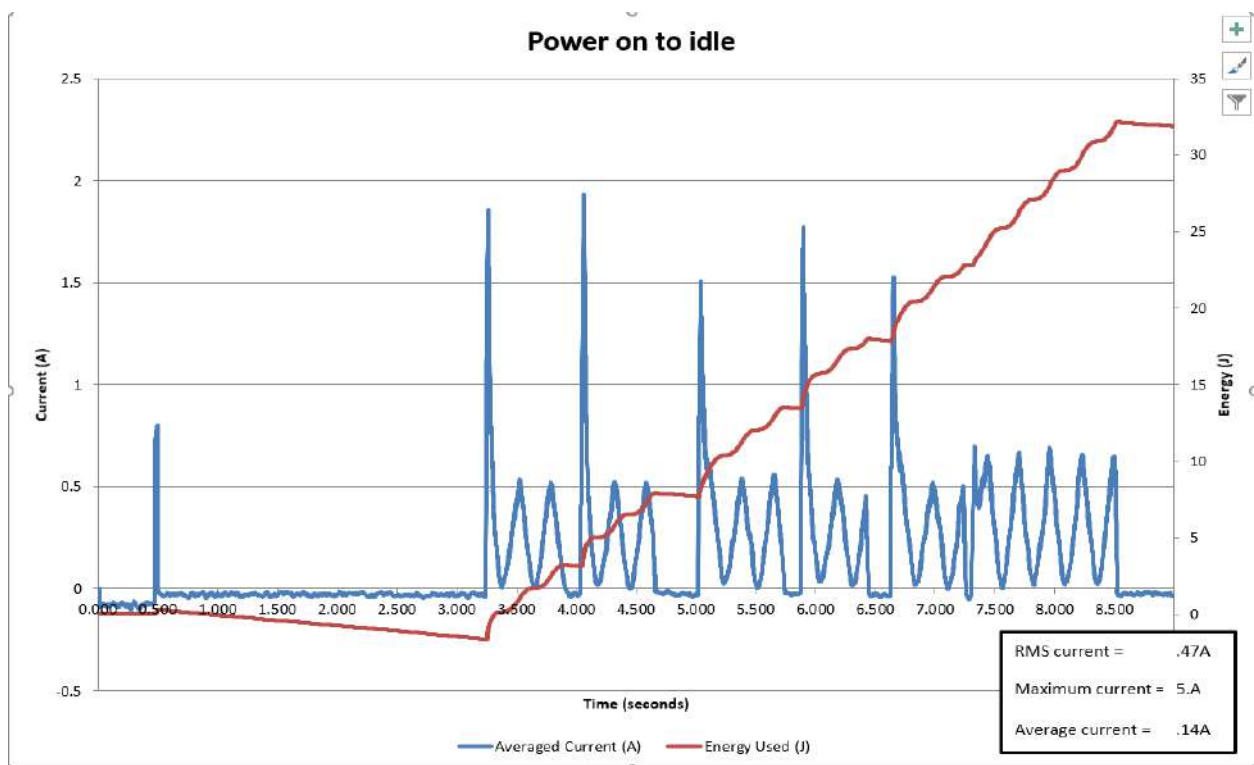

NV200 Family User Manual

[<< Back to Contents](#)

10 second idle

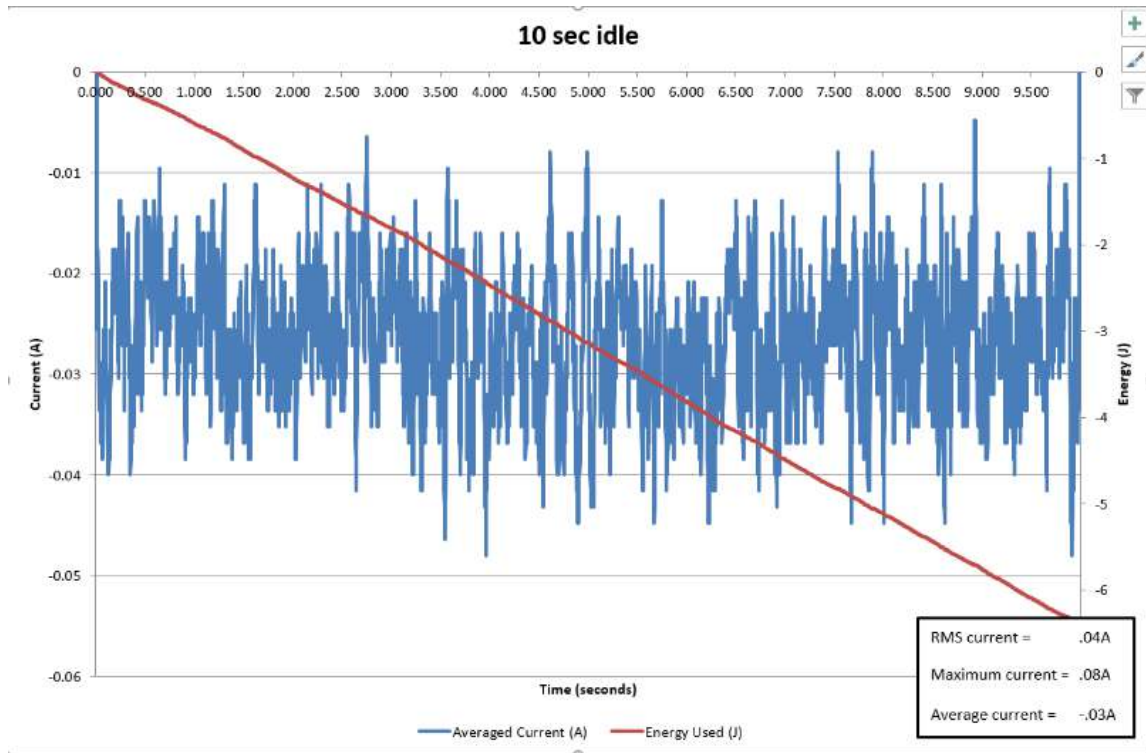

Note insert and accept

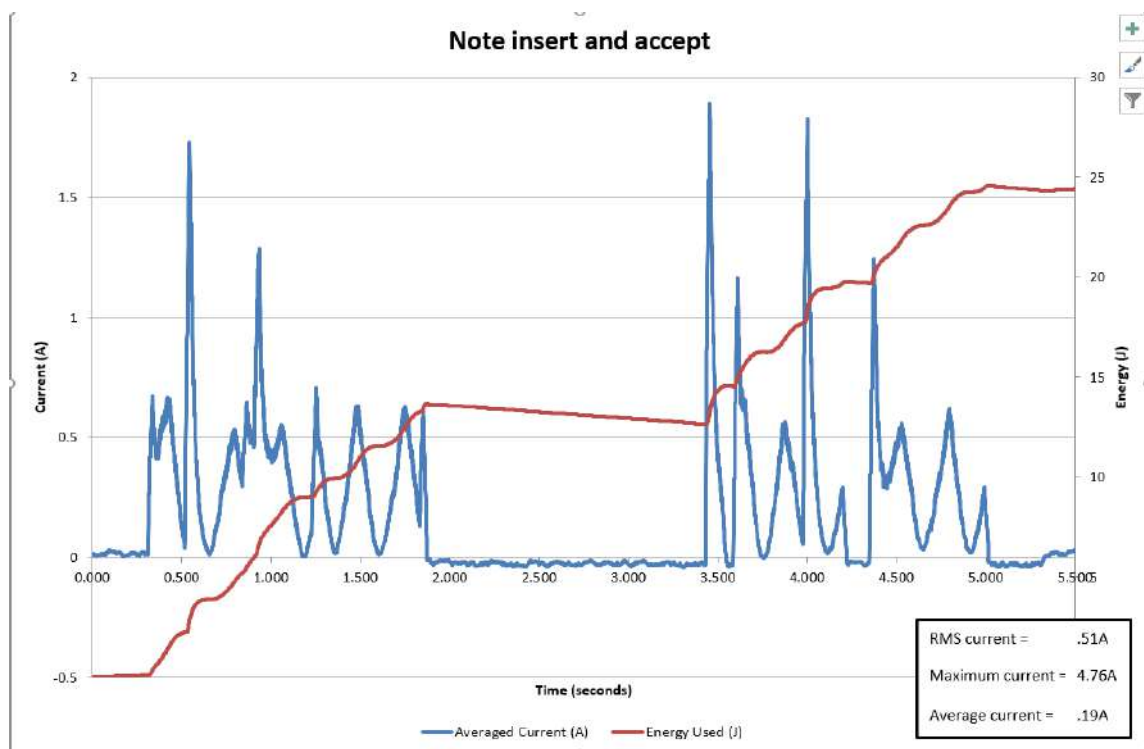

NV200 Family User Manual

[<< Back to Contents](#)

Print ticket (Barcode and text)

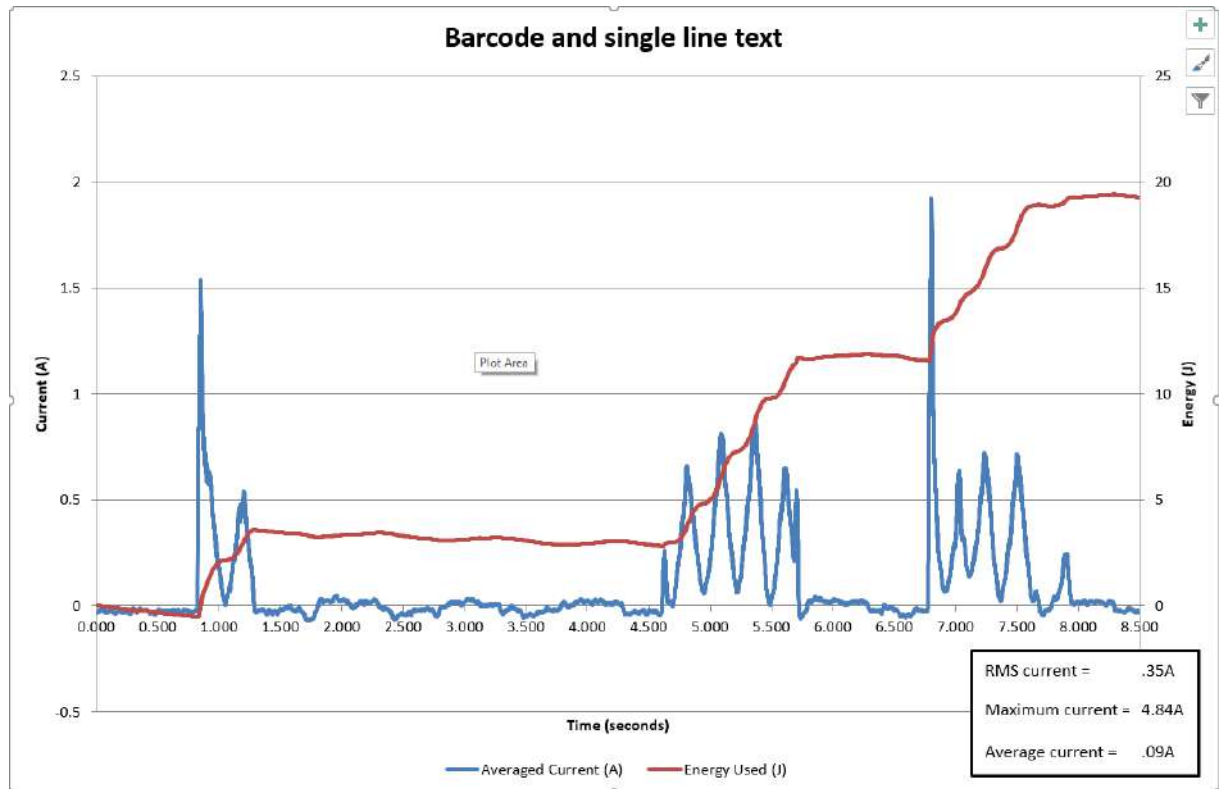

Print ticket (barcode text and images)

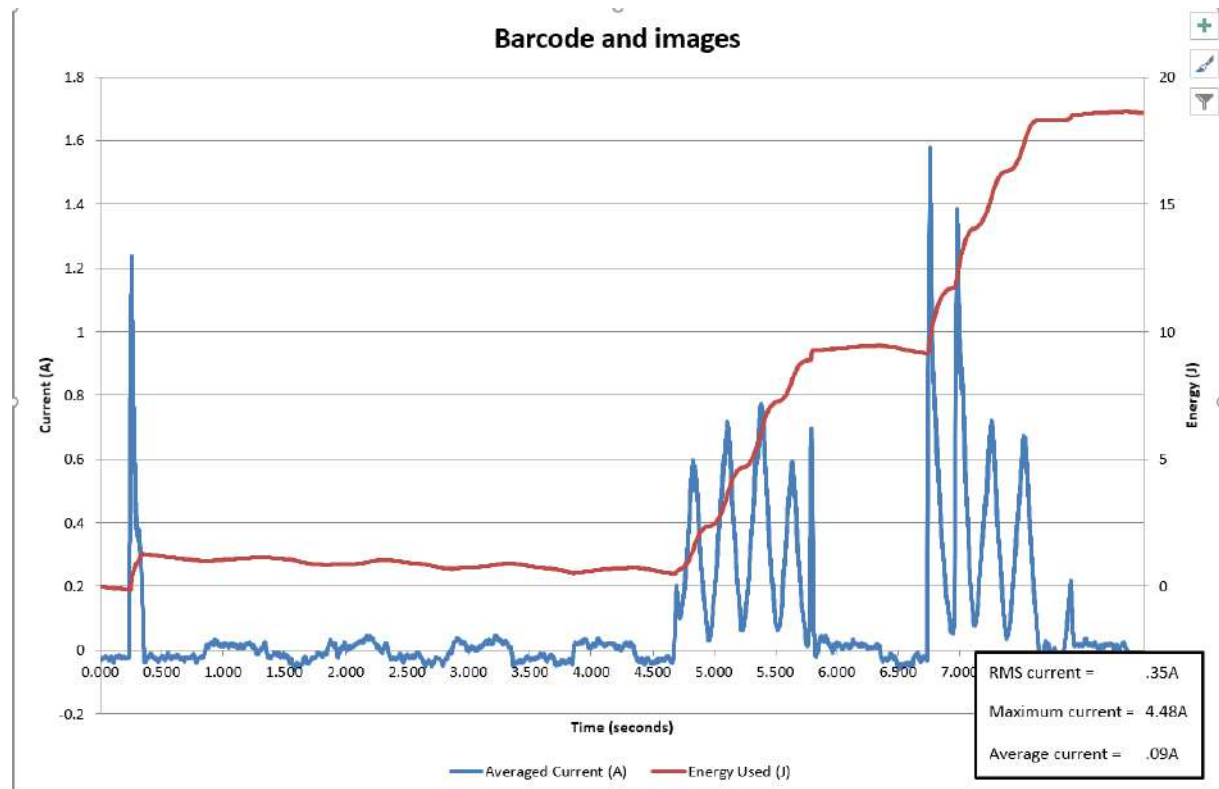

NV200 Family User Manual

[<< Back to Contents](#)

Stacker Full

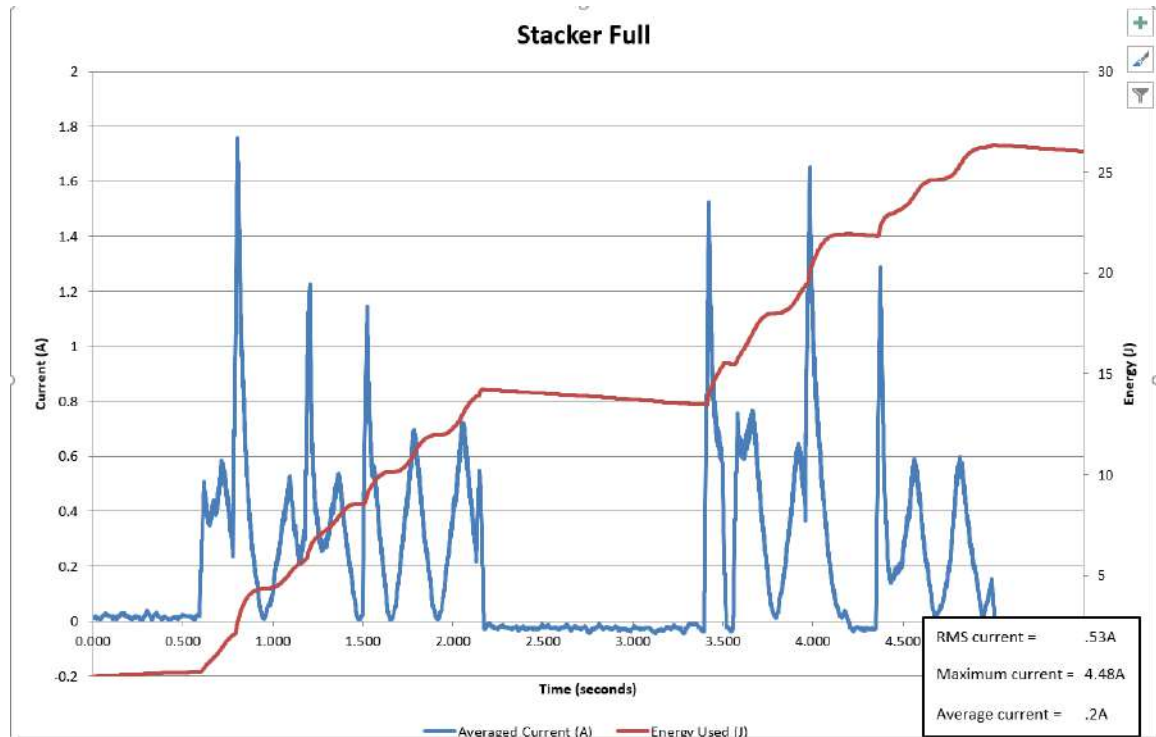

Anti-jam routine

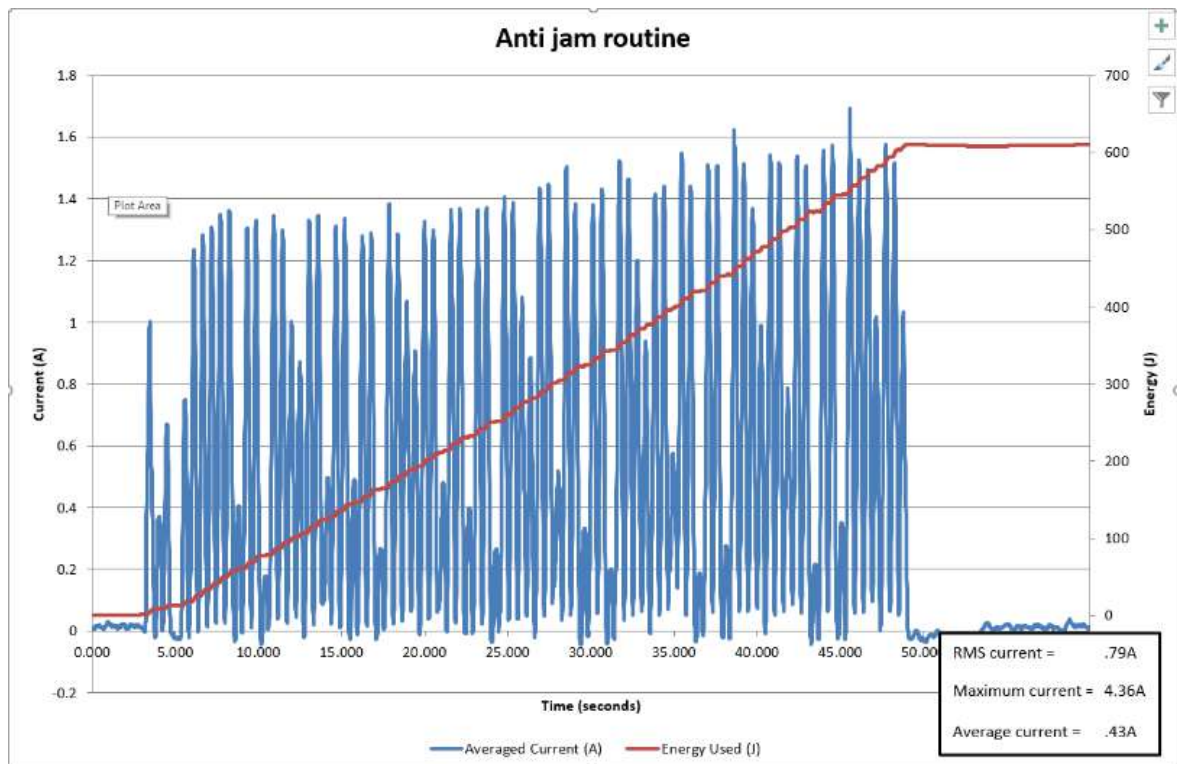

[<< Back to Contents](#)

10.2.4 NV200 with TEBS Cashbox

State: Power on to Idle

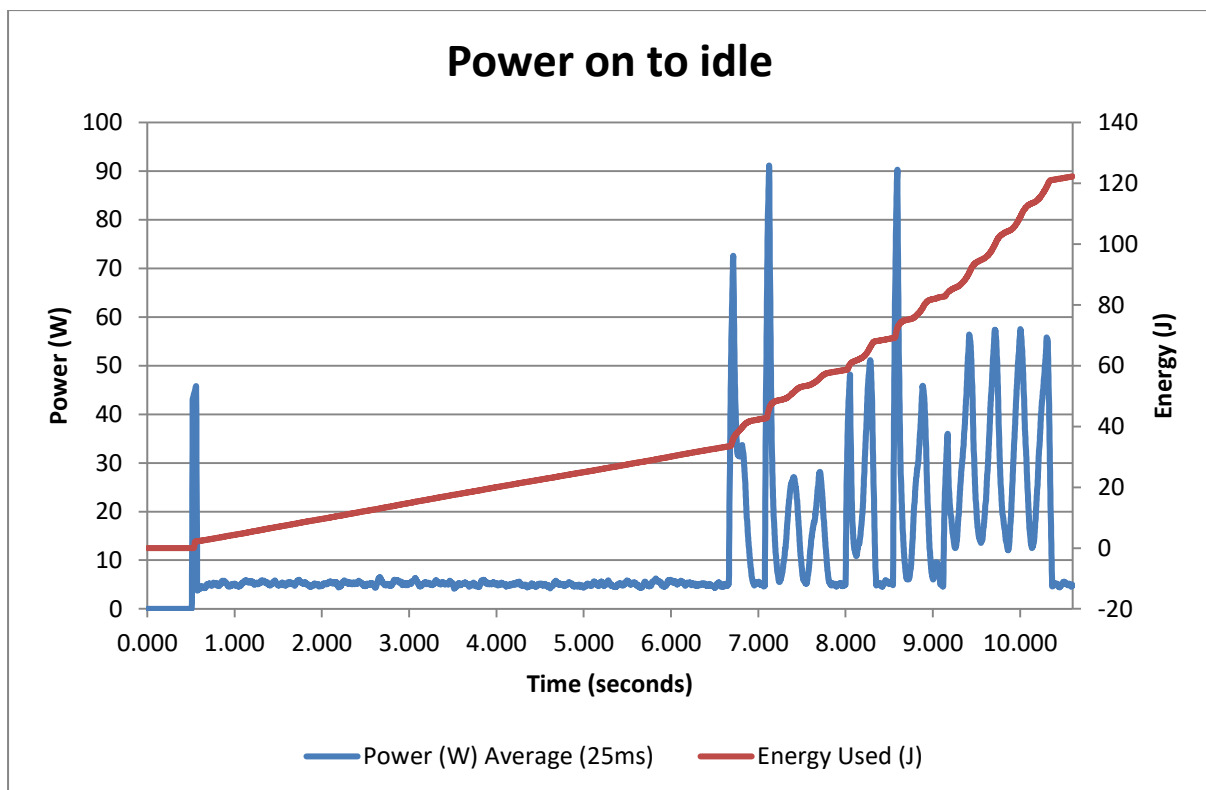
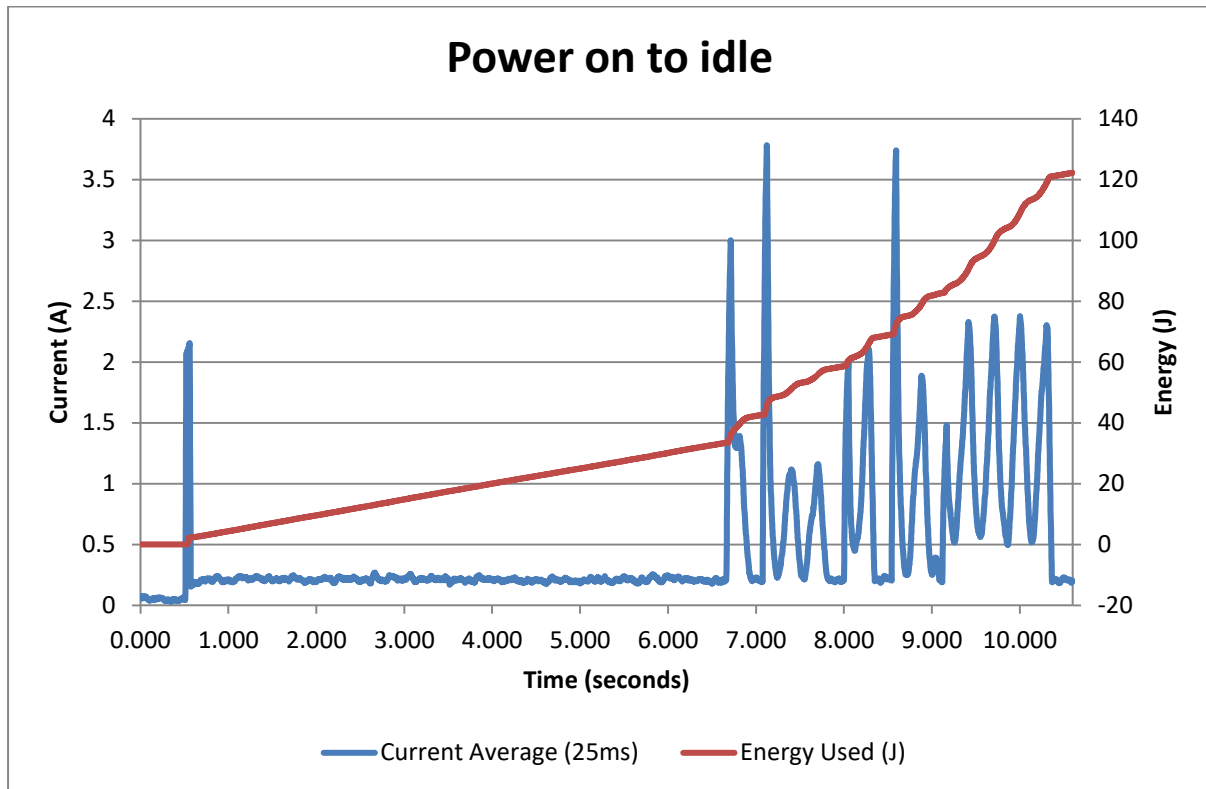

State: Idle



[<< Back to Contents](#)

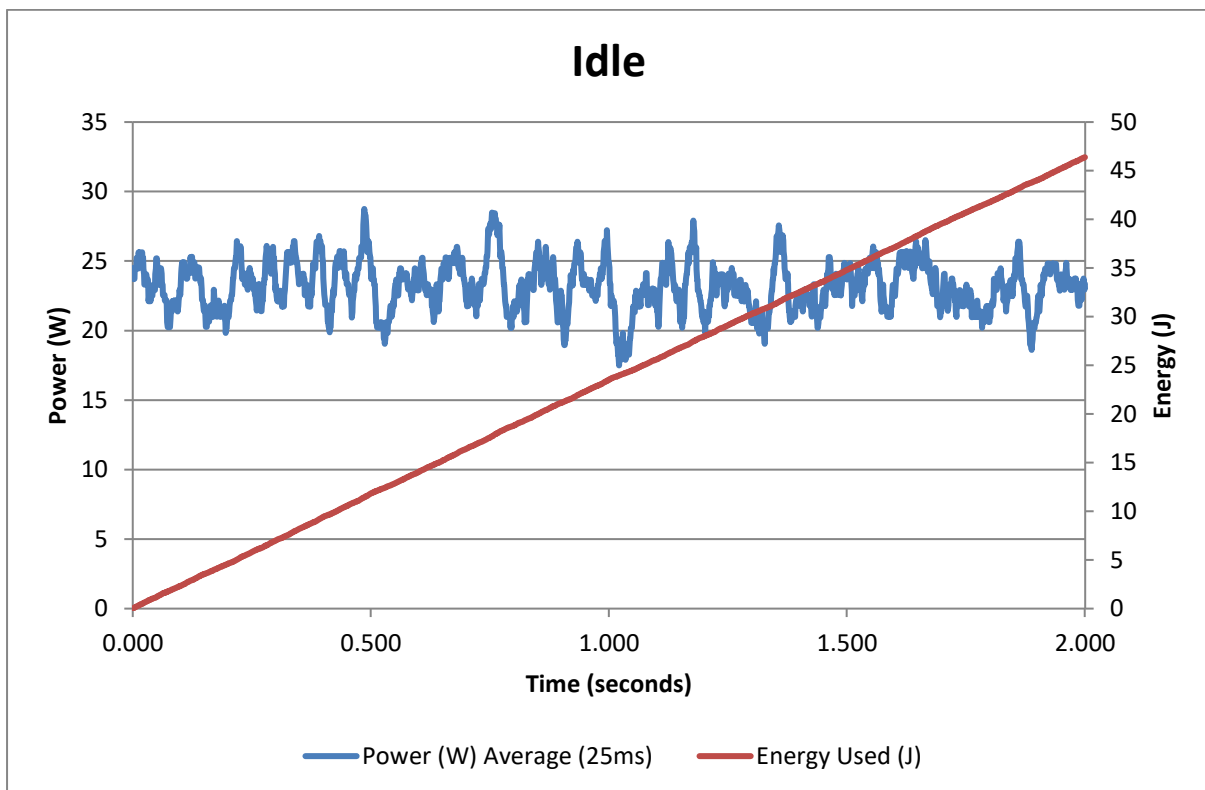
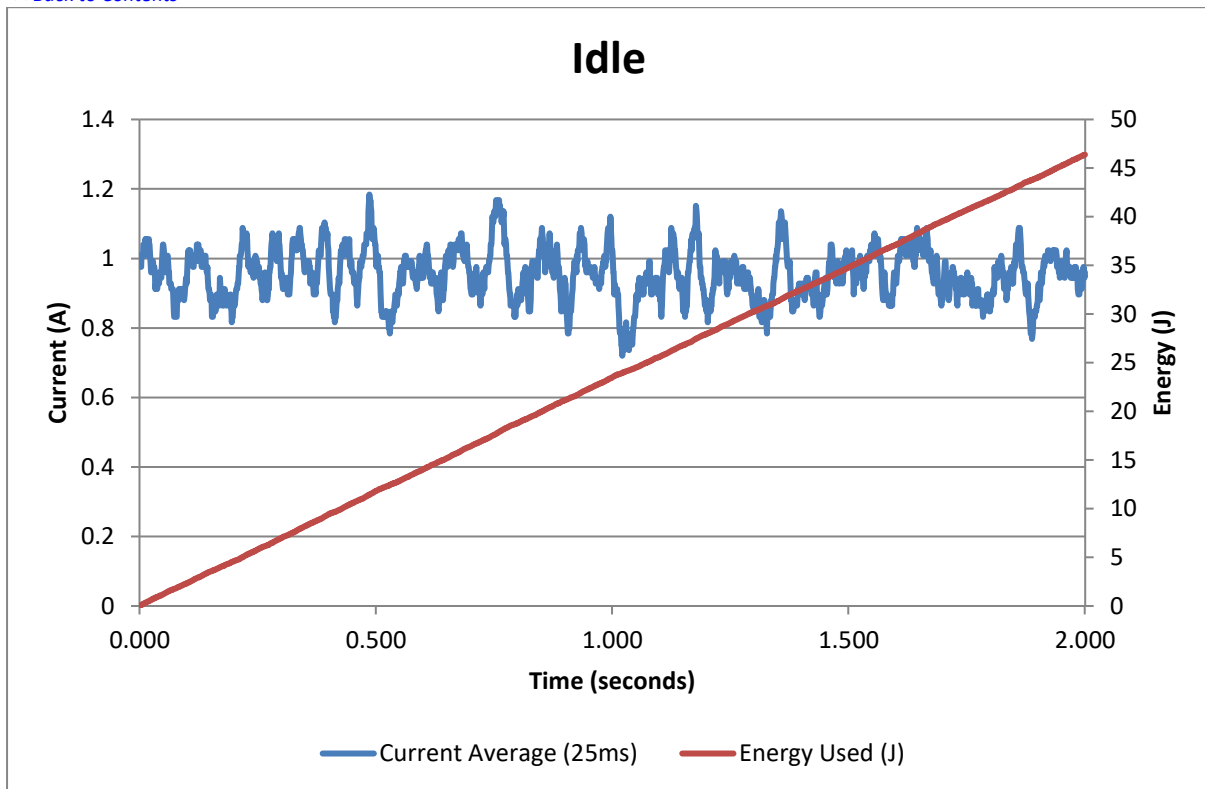

State: Note Accept – empty Bag



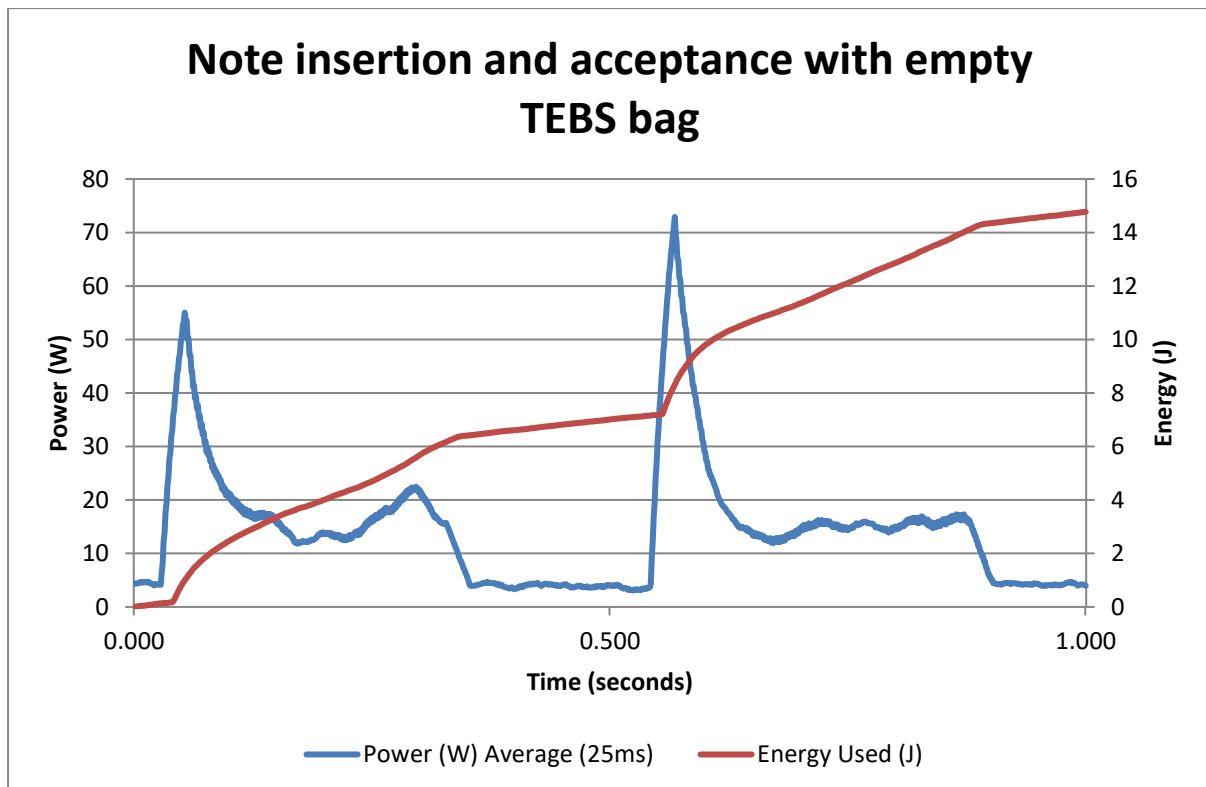
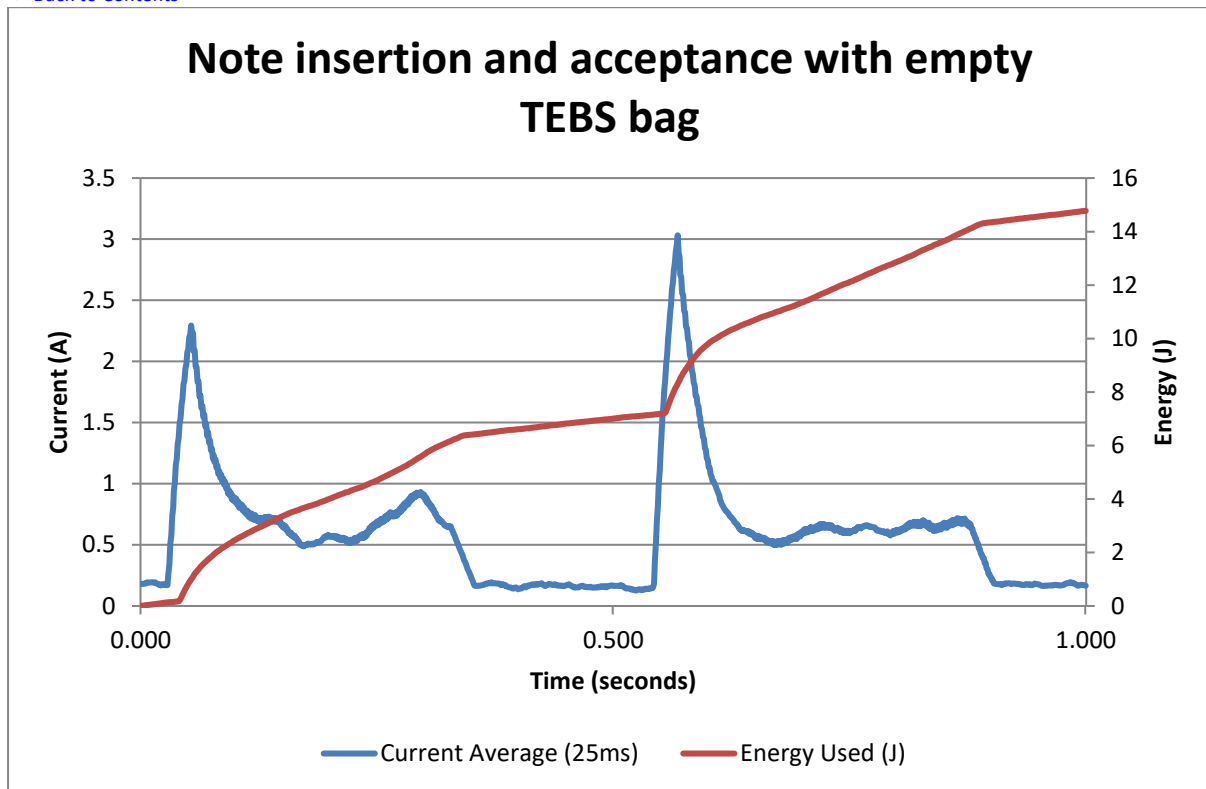

State: Note Accept – half full Bag



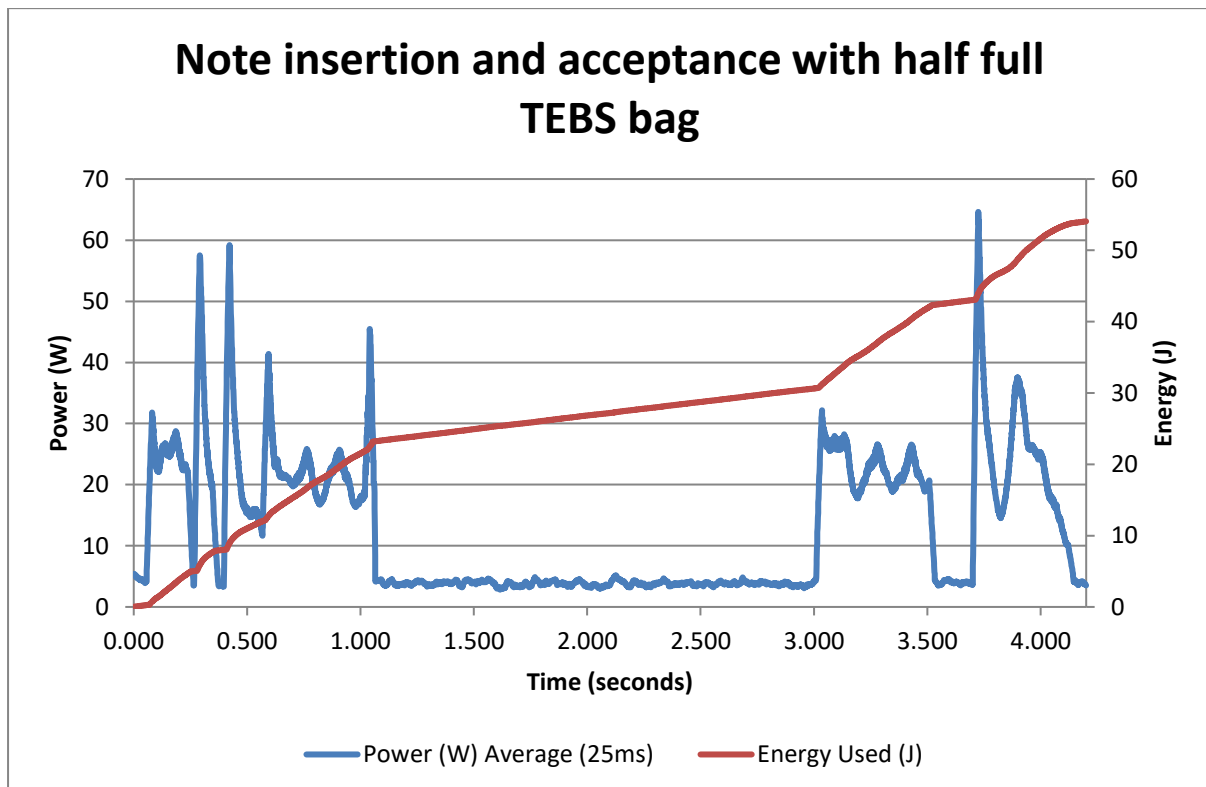
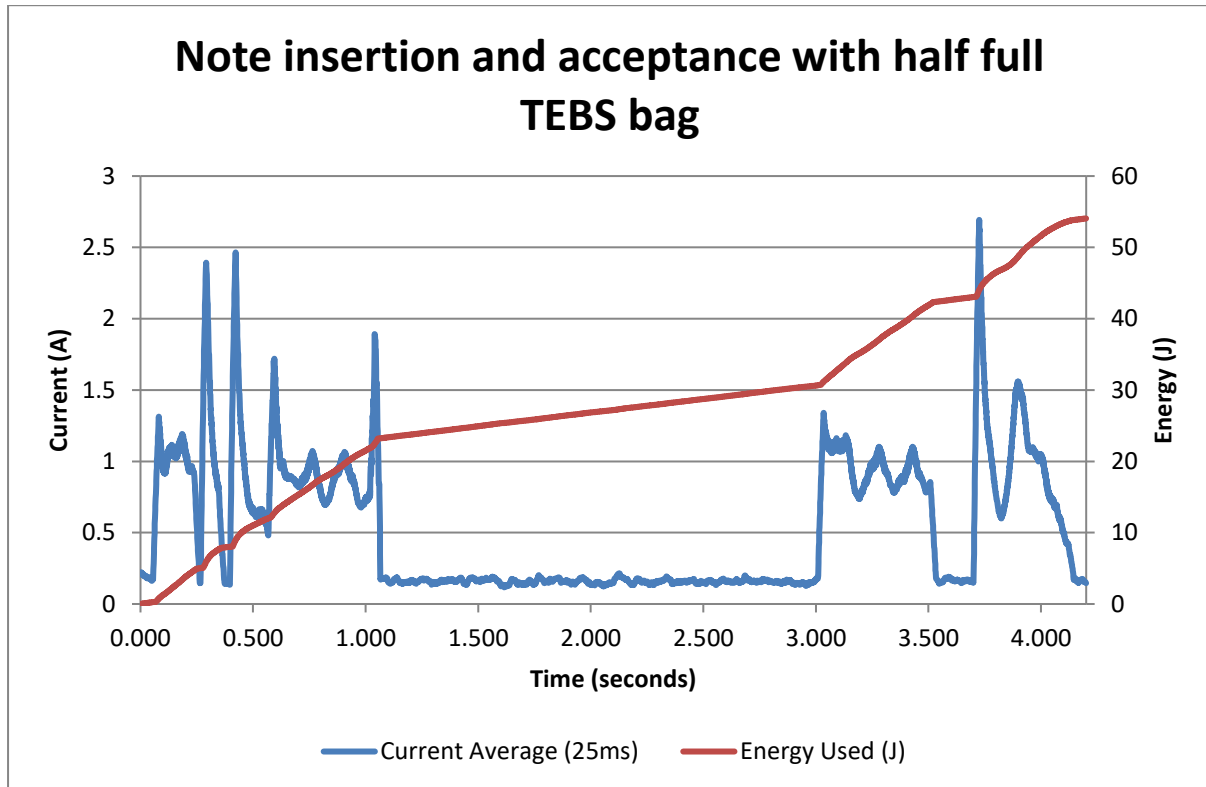

State: Note Accept – full bag



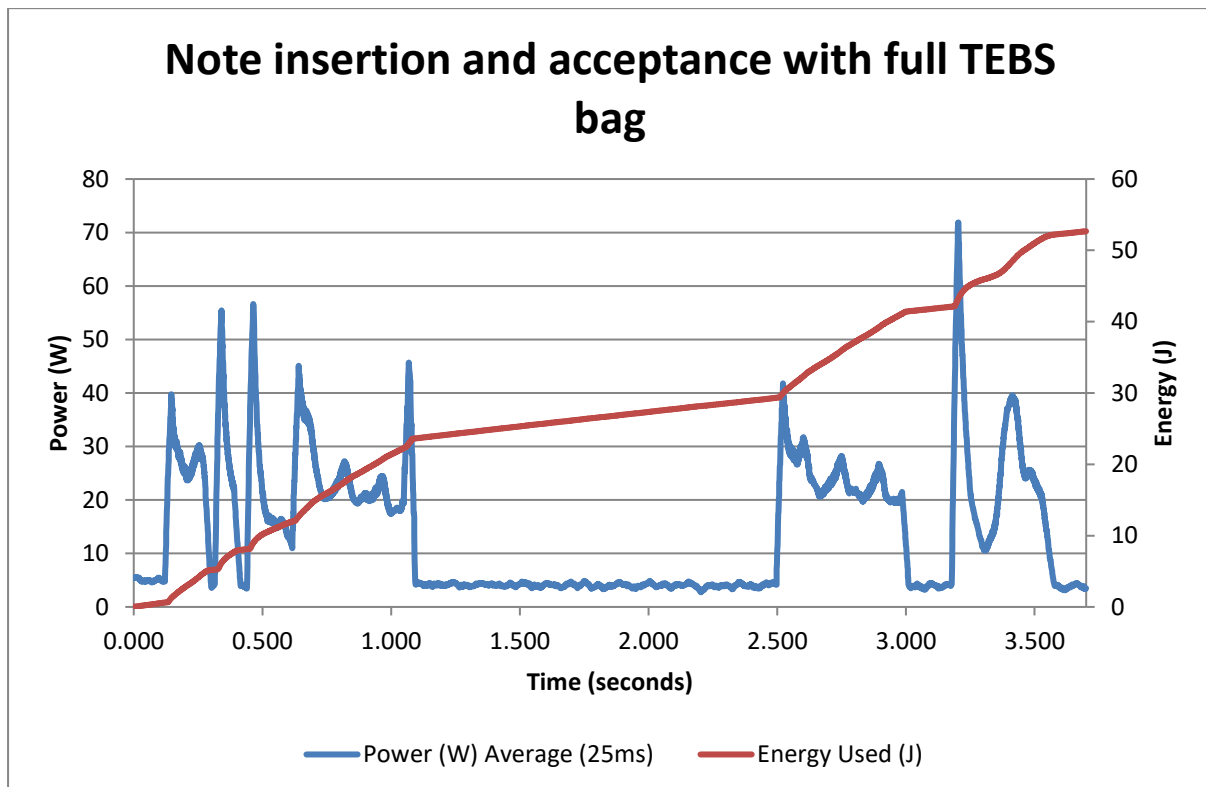
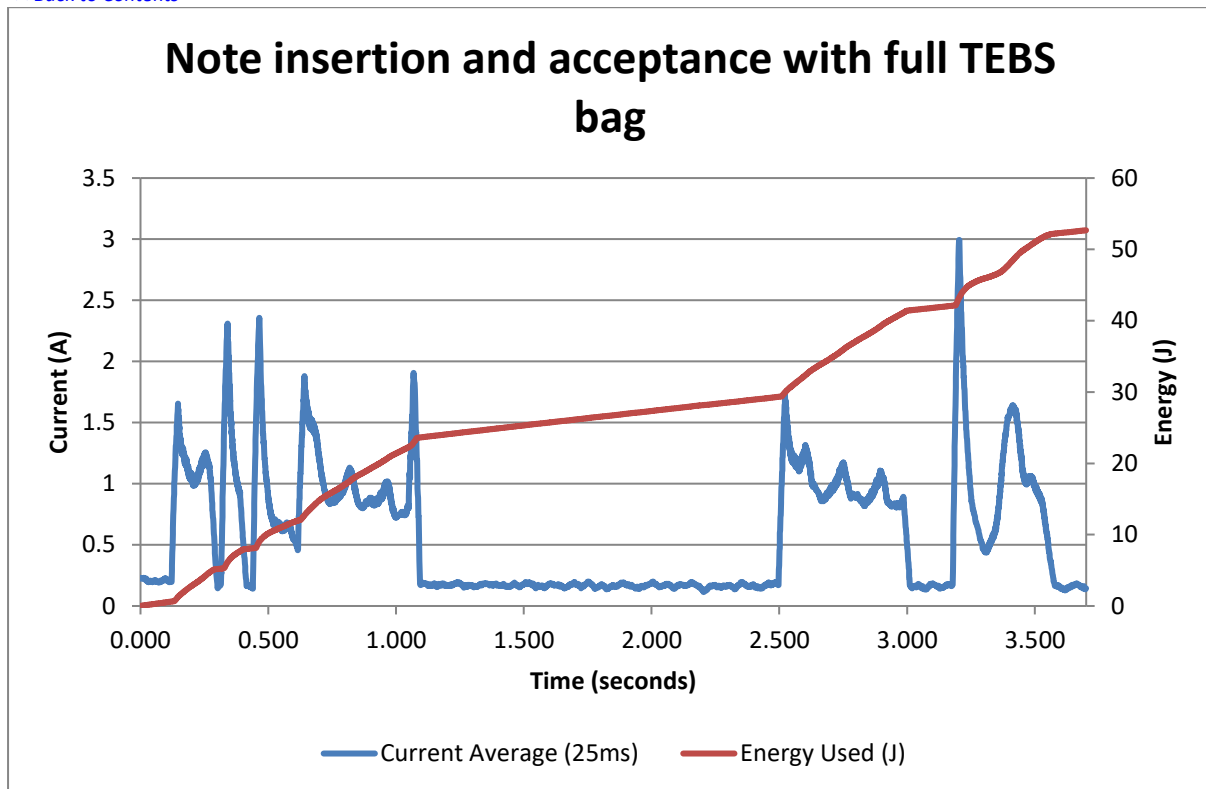

State: Note Reject



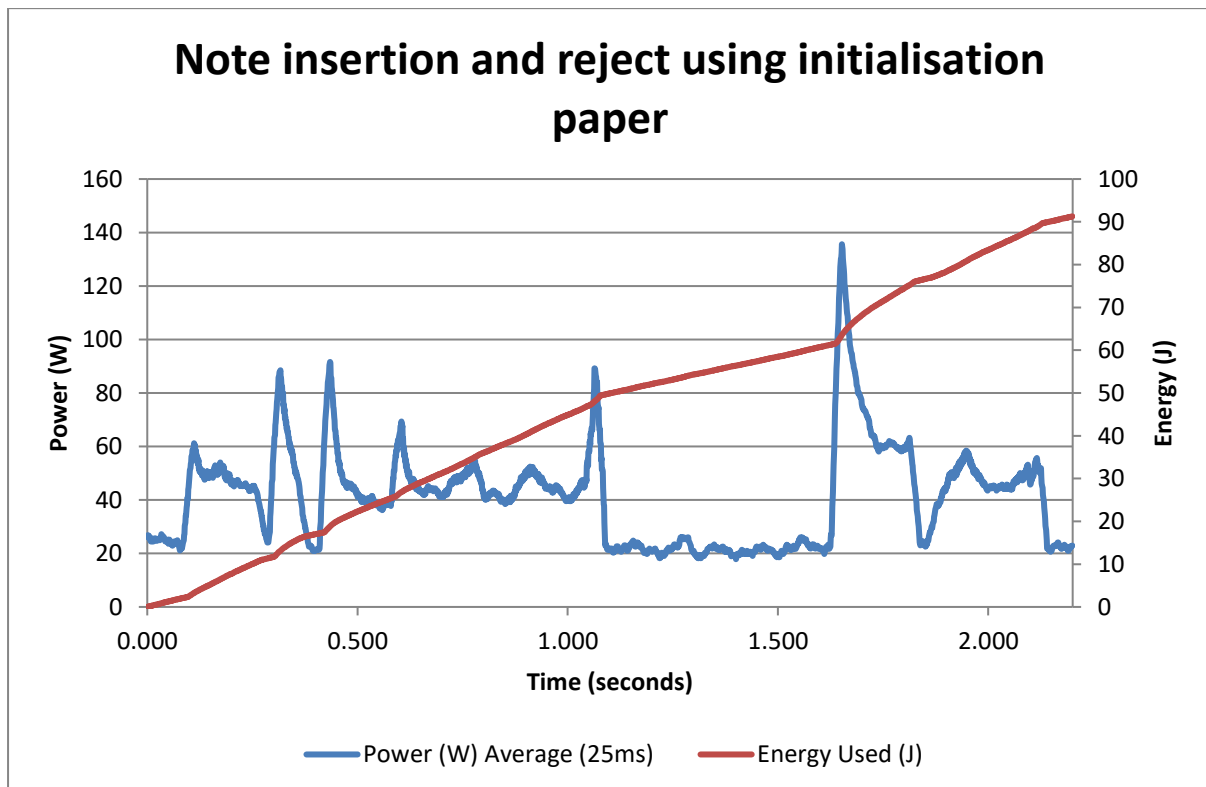
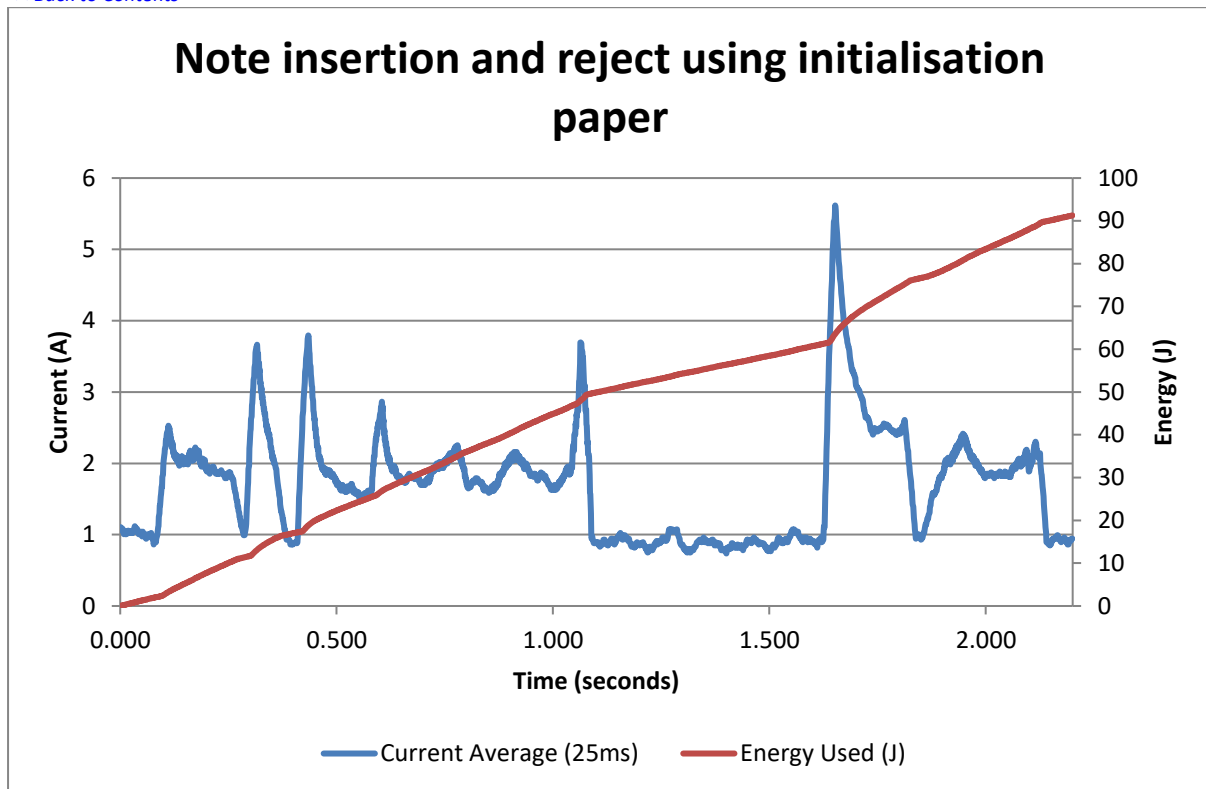

State: Stacking with Anti-jam



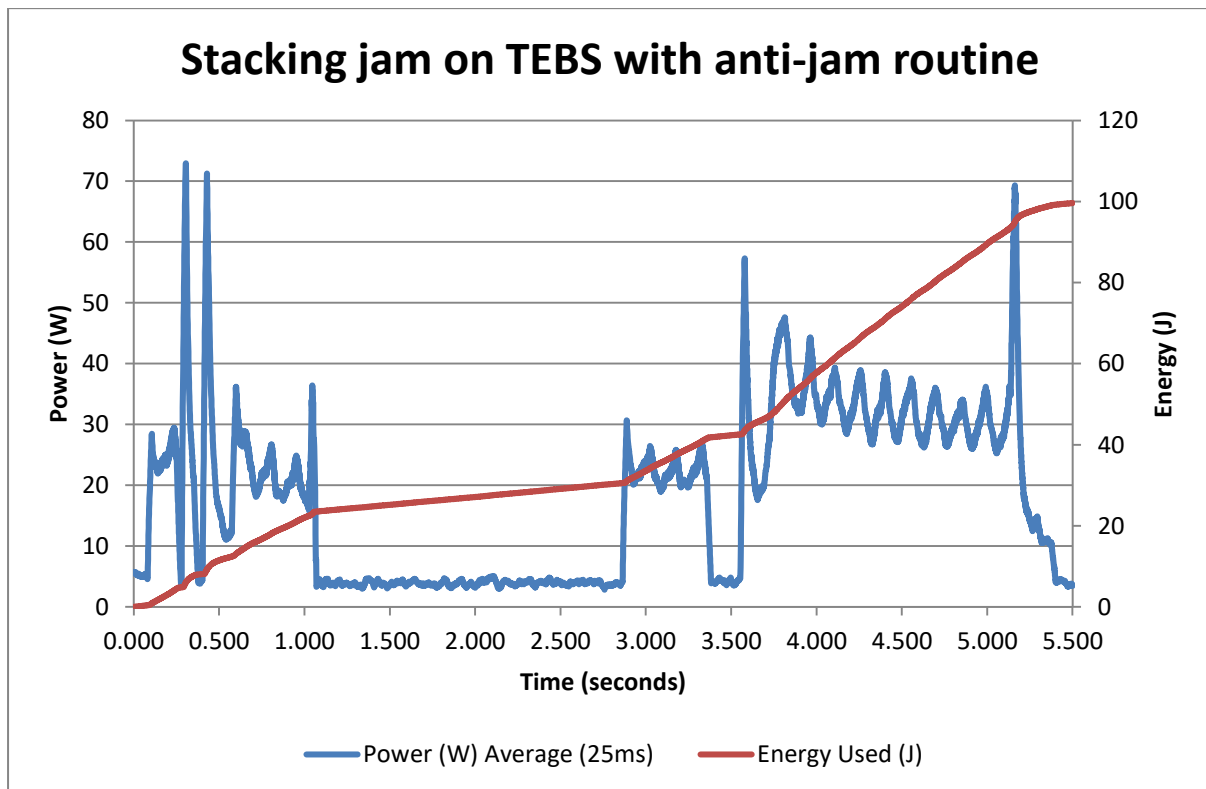
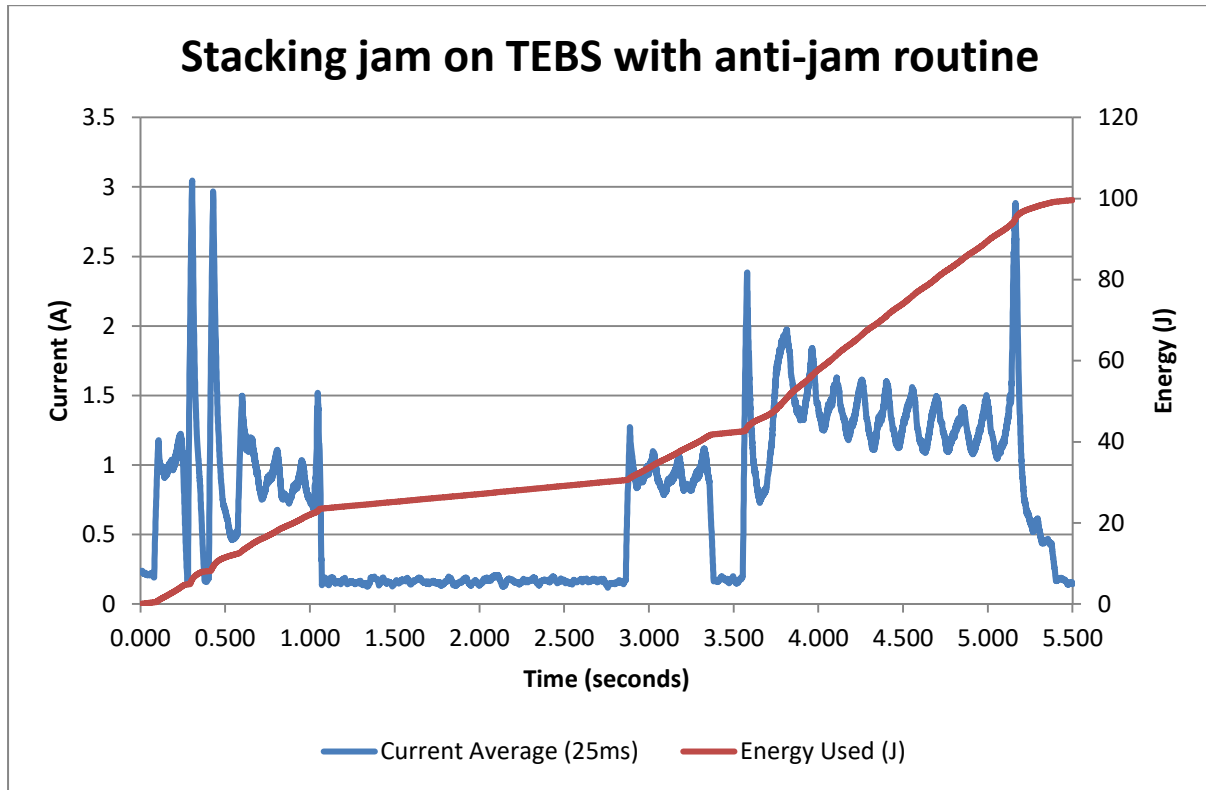

State: NV200 Ant-jam



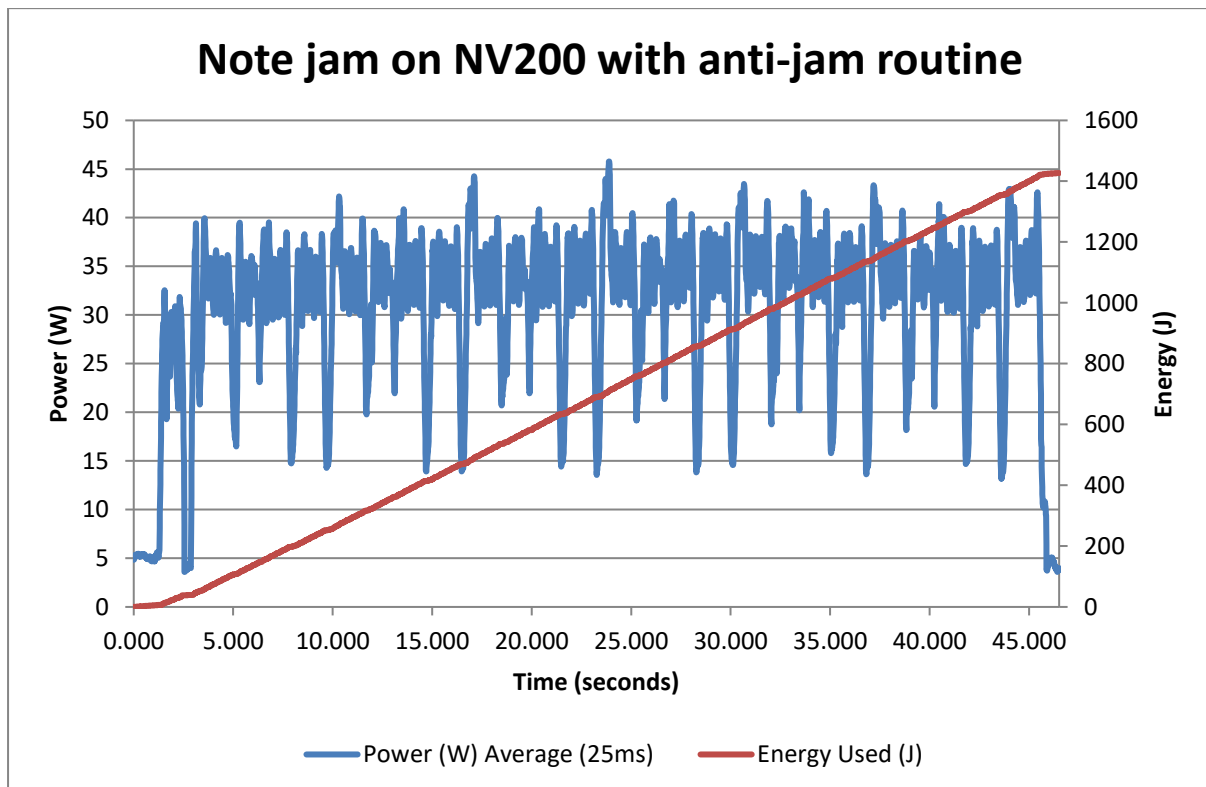
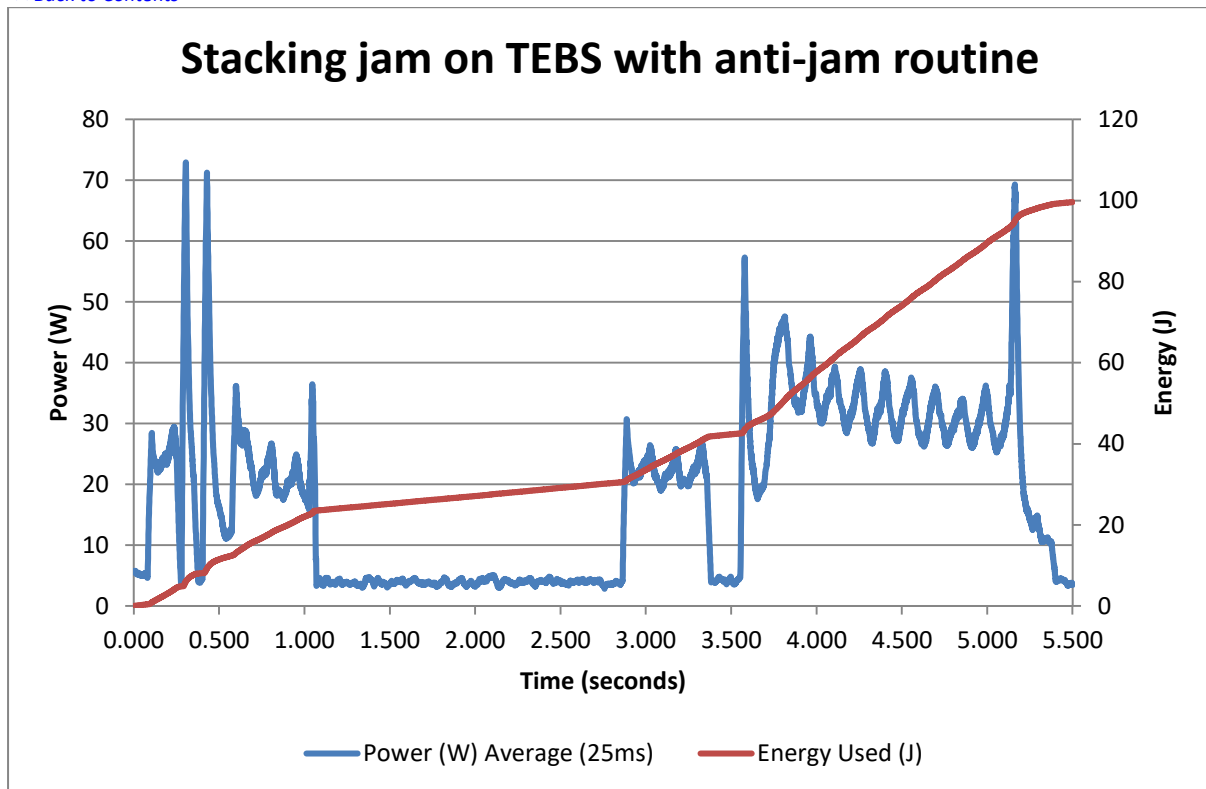

[<< Back to Contents](#)

10.3 Lock Specifications

10.3.1 NV200 Locking CAM

<p>СРОК ВЫПУСКА: 1999-2016</p> <p>МОНТАЖНО-ДЕМОНТАЖНЫЕ РАБОТЫ</p> <p>ИНСТРУКЦИЯ ПО ЭКСПЛУАТАЦИИ</p> <p>СМ. WHITE ИНСТРУКЦИЮ</p> <p>IL IN DOTTEL - YOKUJI DO NOT ASKTE YOE KOMIYUJI SEKKA YUJI DIMENSIYONIAI SHOHUHI</p>	<p>ИЗМЕН. №0</p> <p>MOD №0</p> <p>ДВАЙЕ</p> <p>MOD B.V.</p> <p>NOOD B.V.</p>	<p>НАЗВАНИЕ: БУВЕРО BV100 & ИВС00 СЪРЪНВОХ ГООК</p> <p>ЧЕКОВАНО: ДВАЙЕ</p> <p>ДРАВИНО: ДВАЙЕ</p> <p>МАТЕРИАЛ: ДВАЙЕ</p> <p>ИЗМЕН. №0</p>	<p>ИЗМЕН. №0</p> <p>DISK ID: V112</p> <p>ИЗМЕН. №0</p> <p>LOAD No:</p>	<p>KEY: 2C 20110501011 CHANVCYCLEB2LIC</p> <p>100 - 500 20 - 100 10 - 20 0 - 10</p> <p>ДИМЕНСИОНАЛНИ ИЛЮСТРАЦИИ DIMENSIONED DIMENSION TABLE</p>	<p>1</p> <p>2</p> <p>3</p> <p>4</p> <p>5</p> <p>6</p> <p>7</p> <p>8</p> <p>9</p> <p>10</p> <p>11</p> <p>12</p> <p>13</p> <p>14</p> <p>15</p> <p>16</p> <p>17</p> <p>18</p> <p>19</p> <p>20</p> <p>21</p> <p>22</p>	<p>↑</p> <p>X</p> <p>W</p> <p>V</p> <p>U</p> <p>2HT</p> <p>1</p>
---	--	--	--	--	--	--

СЪРЪНВОХ БСАТ ИЛЮСТРАЦИЯ: S8D181C6A

mm



NV200 Family User Manual

[<< Back to Contents](#)

10.3.2 TEBS Locking CAM

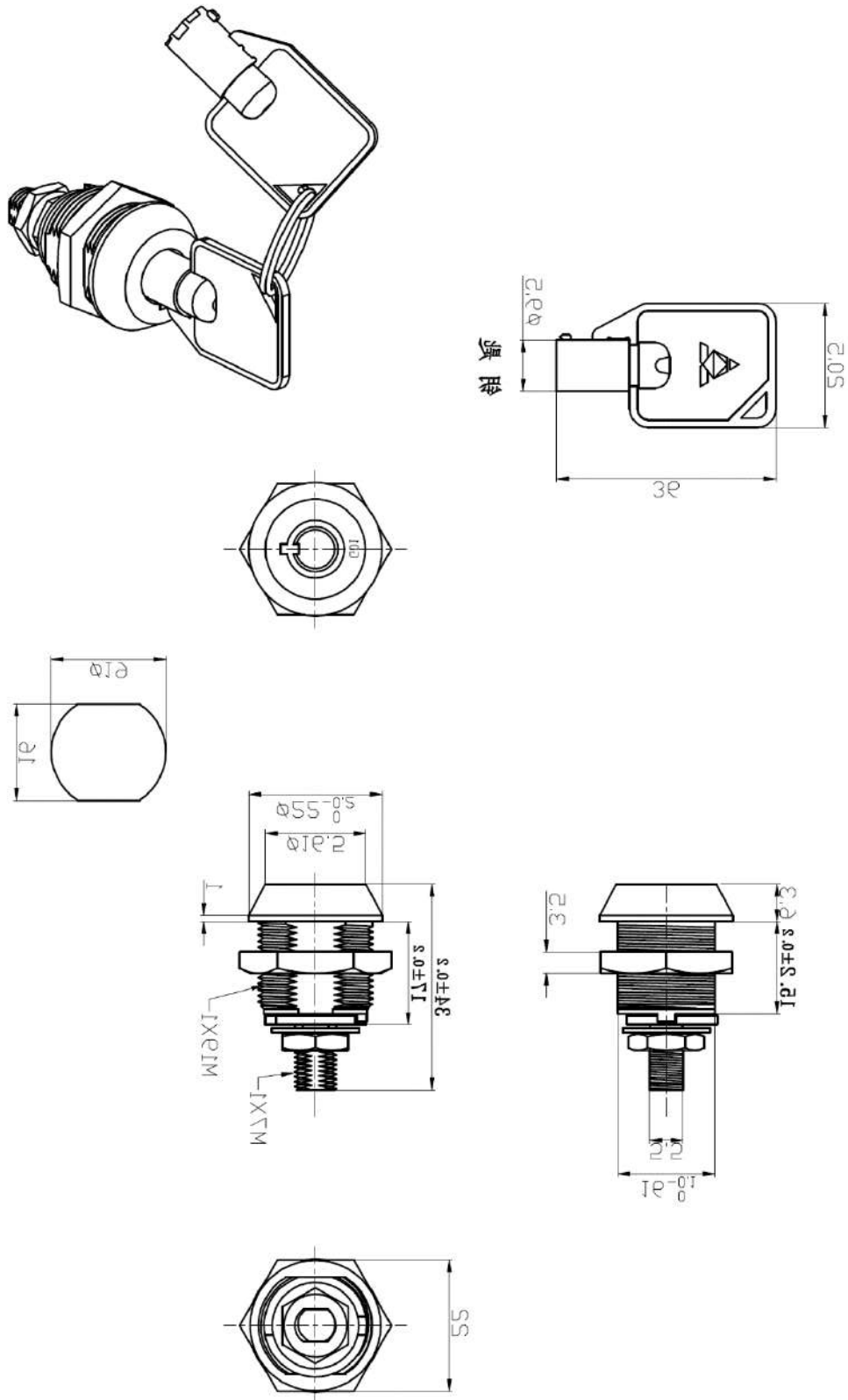

10.4 Cable Drawings

10.4.1 CN214

DRAWING NO. CN00214 ISSUE A																																																																
<p>Note to Manufacturers</p> <p>Certificates are needed for the following: ■ RoHS compliance ■ UL 94-V0 rated (connector housing) ■ UL 94-VW1 rated (all other parts)</p>																																																																
<p>Parts List</p> <table border="1" style="width: 100%; border-collapse: collapse;"> <thead> <tr> <th>Item</th> <th>QTY</th> <th>Description</th> <th>Vendor</th> </tr> </thead> <tbody> <tr> <td>A</td> <td>1</td> <td>USB Type A Male Connector</td> <td>-</td> </tr> <tr> <td>B</td> <td>1</td> <td>USB Shielded High Speed 2.0 Cable 28AWG/P+28AWG/2</td> <td>-</td> </tr> <tr> <td>C</td> <td>1</td> <td>USB Type B Male Connector</td> <td>-</td> </tr> </tbody> </table>													Item	QTY	Description	Vendor	A	1	USB Type A Male Connector	-	B	1	USB Shielded High Speed 2.0 Cable 28AWG/P+28AWG/2	-	C	1	USB Type B Male Connector	-																																				
Item	QTY	Description	Vendor																																																													
A	1	USB Type A Male Connector	-																																																													
B	1	USB Shielded High Speed 2.0 Cable 28AWG/P+28AWG/2	-																																																													
C	1	USB Type B Male Connector	-																																																													
<p>Comments</p>																																																																
<p><i>All dimensions are in mm ±5mm, unless specified</i></p>																																																																
<table border="1" style="width: 100%; border-collapse: collapse;"> <tr> <td colspan="13"> <p>APPROVED BY: DATE: 15/03/2013</p> </td> </tr> <tr> <td colspan="13"> <p>DESIGNED BY: C. Cardoza DATE: 15/03/2013</p> </td> </tr> <tr> <td colspan="13"> <p>ISSUE NO. A</p> </td> </tr> <tr> <td colspan="13"> <p>MODIFIED BY: C. Cardoza DATE: 15/03/2012</p> </td> </tr> </table>													<p>APPROVED BY: DATE: 15/03/2013</p>													<p>DESIGNED BY: C. Cardoza DATE: 15/03/2013</p>													<p>ISSUE NO. A</p>													<p>MODIFIED BY: C. Cardoza DATE: 15/03/2012</p>												
<p>APPROVED BY: DATE: 15/03/2013</p>																																																																
<p>DESIGNED BY: C. Cardoza DATE: 15/03/2013</p>																																																																
<p>ISSUE NO. A</p>																																																																
<p>MODIFIED BY: C. Cardoza DATE: 15/03/2012</p>																																																																
<p>REVISIONS:</p> <table border="1" style="width: 100%; border-collapse: collapse;"> <thead> <tr> <th>NO.</th> <th>DATE</th> <th>DESCRIPTION</th> </tr> </thead> <tbody> <tr> <td>1</td> <td>15/03/2012</td> <td>Initial Issue</td> </tr> </tbody> </table>													NO.	DATE	DESCRIPTION	1	15/03/2012	Initial Issue																																														
NO.	DATE	DESCRIPTION																																																														
1	15/03/2012	Initial Issue																																																														

NV200 Family User Manual

[<< Back to Contents](#)

10.4.2 CN292

DRAWING NO.	ISSUE		
CN292	4		

Terminal

CON1
CON2

Housing

Leotronics 2652-2161 (2x8way 2.54mm pitch with key)
Leotronics 2652-2161 (2x8way 2.54mm pitch with key)

Crimp

2653-2000 (tin plated)
2653-2000 (tin plated)

Accepted alternatives: 90119-0110 (Molex crimps) and 90142-0016 (Molex housing)

Connectivity by conductor

CON1 Pin	CON2 Pin	Gauge (AWG)	Colour	Comments
1	1	24	Orange	-
5	5	24	Brown	-
15	15	24	Red	VIN
16	16	24	Black	GND

Note:
Pins 3,4,7,8,9,10,13 and 14 are unloaded
Pins 2,6,11 and 12 are loaded but not connected

REVISE NO.	REVISED BY	DATE	DESCRIPTION	APPROVED BY	DATE
4	A Lunsong	27/08/09	A Lunsong		

DRAWN BY	CHECKED BY	DATE	DATE	TOOL NO.	FINISH
A Lunsong		27/08/09			

TITLE	2008	Copyright of	Innovative Technology Ltd	NOT TO SCALE	All dimensions in mm ±2mm
IF10 - SSP to Binary Interface Cable					

All parts must be rated to at least UL94V-0	All connector housings must be rated to UL94V-0
---	---

	INNOVATIVE TECHNOLOGY LIMITED 11, HANOVER STREET, LONDON, E1 6AN, U.K. TEL: +44(0)20 7323 8388 FAX: +44(0)20 7323 8399		SHANGHAI PRODUCTION
--	---	--	---------------------



NV200 Family User Manual

[<< Back to Contents](#)

10.4.3 CN345

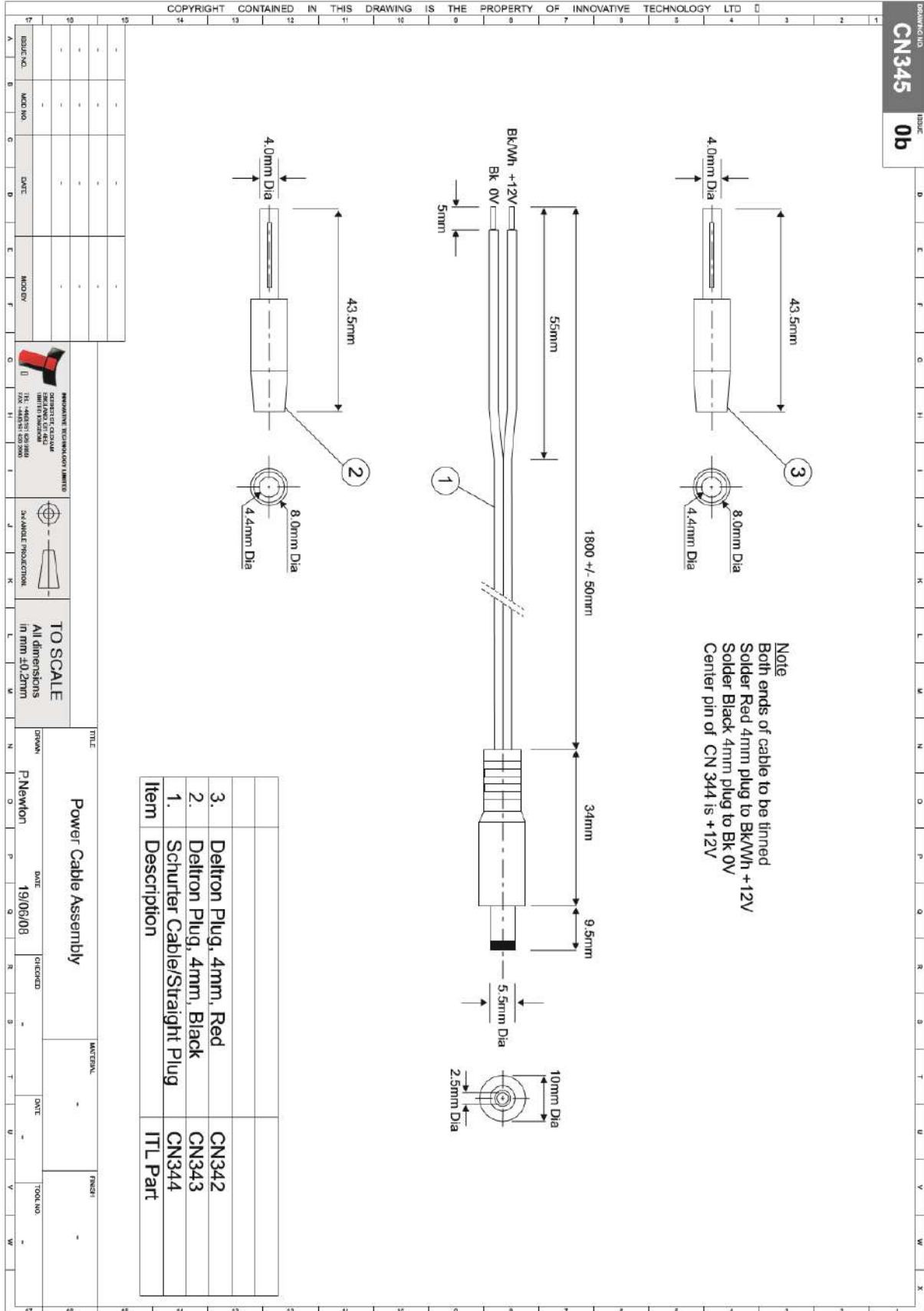

[<< Back to Contents](#)

10.4.4 CN389

DRAWING NO.		CN389		ISSUE		2	
-------------	--	--------------	--	-------	--	----------	--

Parts List

Item	QTY	Description	Part Number	Vendor
A	1	4mm Stackable Plug, Red	553-0500-01	Deltron
B	1	4mm Stackable Plug, Black	553-0100-01	Deltron
C	1	Polarised Audio Wire, 2 x 0.5mm ² AWG 20-18	-	-
D	1	4 Circuit Receptacle Housing, 4.2mm PE Series UL94V-2	794954-4	Tyco
E	2	4.2mm PE Series Crimp Socket (Not Shown)	1586315-1	Tyco

Connectivity

CON1	CON2	CON3	Colour	Comments
Pin 1	Pin 1	Pin 1	Black/Red	24V (Hopper Power)
Pin 2	Pin 2	Pin 2	Black	0V (Hopper GND)

Note:
All other pin locations are empty.
Audio wire colour is not important but polarisation marking is required.

All parts must be rated to at least UL94-VW1

2009 © Copyright of Innovative Technology Ltd

NOT TO SCALE
All dimensions in mm ±2mm

DRAWN BY		P. Newton	
DATE		14/05/2009	
CHECKED BY		-	
DATE		-	
TITLE		Hopper Interface Power Cable	
REVISION		All Materials used must be RoHS Compliant	
TOLERANCE		-	



NV200 Family User Manual

[<< Back to Contents](#)

10.4.5 CN398

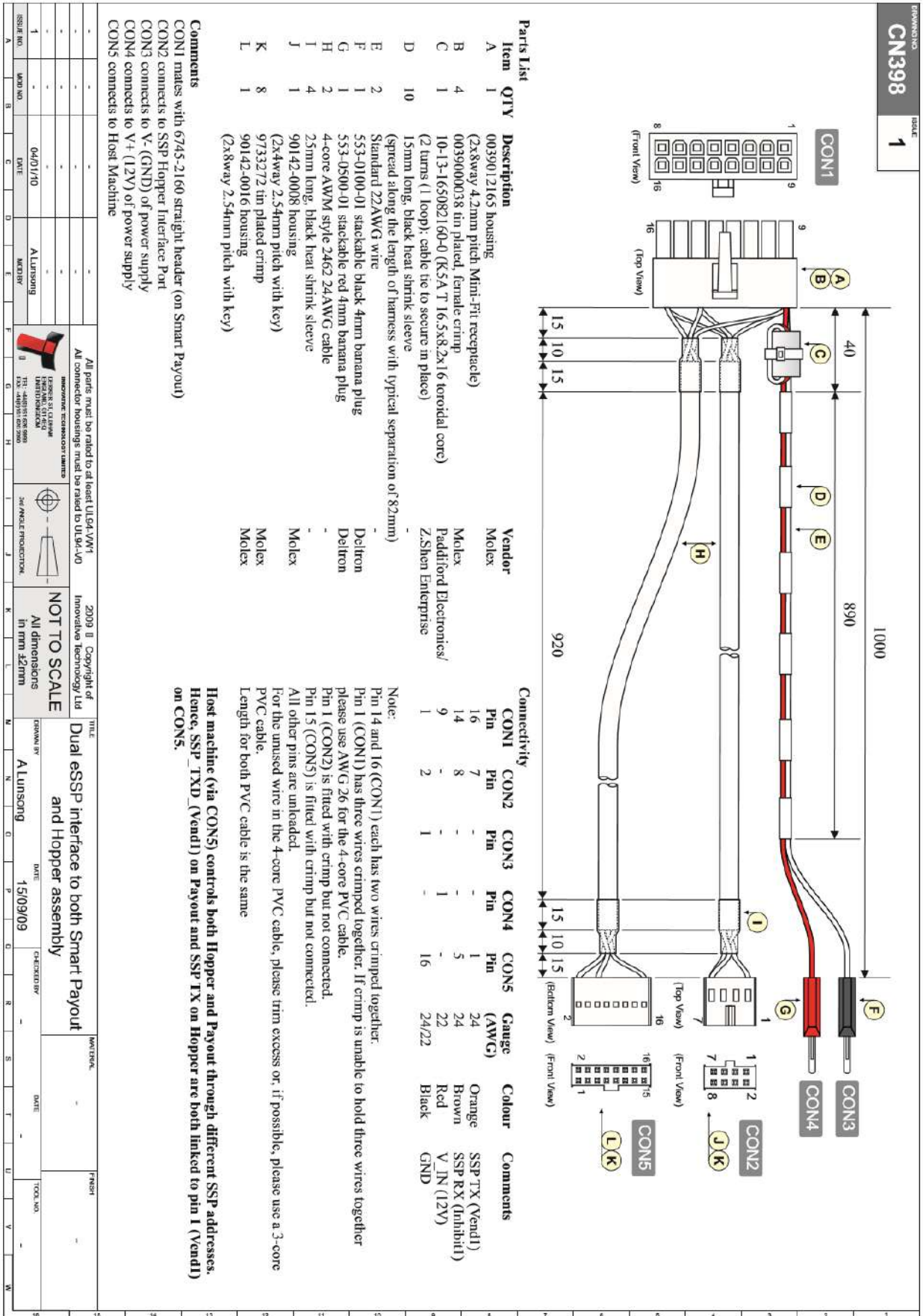

10.4.6 CN414

DRAWING NO. **CN414**
ISSUE **1**

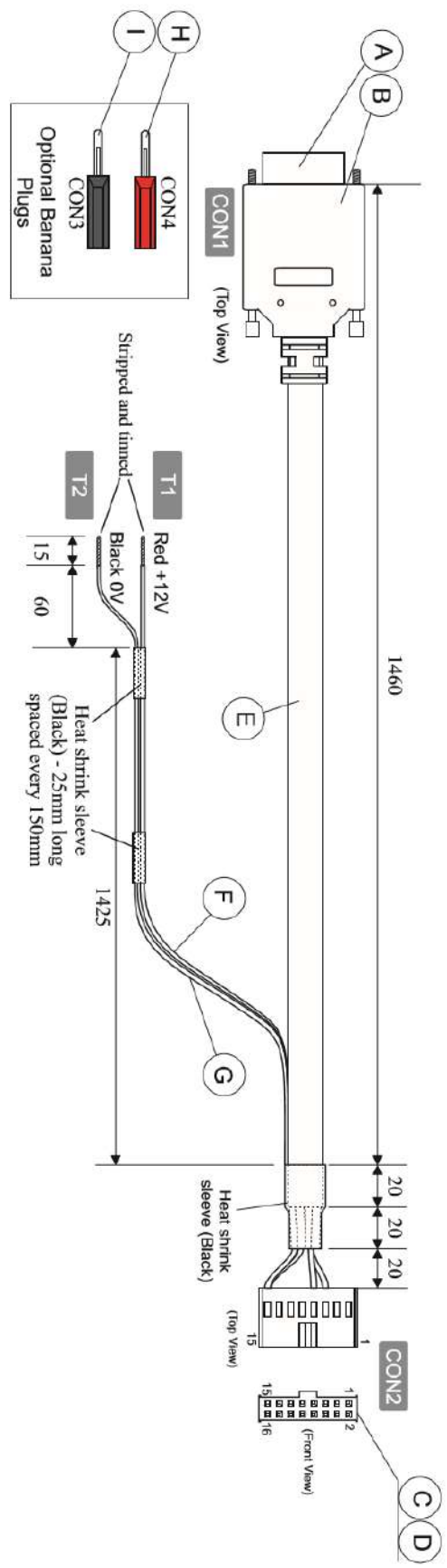

Item	Description
A	MULTICOMP - 5501-09SA-02-F1, SOCKET, D, SOLDER, 9WAY (Farnell 1084678)
B	MH CONNECTORS D1PK9-BLACK-K, D-Sub Shell Plastic 9 Way (Farnell 469-889)
C	MOLEX 9733272, Crimp (tin plated)
D	MOLEX 90142-0016, (2x8way 2.54mm pitch with key)
E	Use 3 or 4 core AWM Style 2464 24AWG Cable, as available (Cut away any unused wires).
F	Red Cable rated to UL1007
G	Black Cable rated to UL1007
H	DELTRON 553-0500-01, Stackable Red 4mm banana plug (Optional).
I	DELTRON 553-0100-01, Stackable Black 4mm banana plug (Optional).

Comments
 CON1 Connects with Host
 CON2 Connects to Validator
 T1 Connects to 12V Power Supply
 T2 Connects to 0V(GND) of Power Supply

Connectivity by conductor

CON1 Pin	CON2 Pin	CON3 Pin	CON4 Pin	Gauge (AWG)	Colour	Comments
2	6	-	-	24	Brown	RX(DTE-DCE)
5	16	-	-	24	Black	GND
3	7	-	-	24	Orange	TX(DTE-DCE)
-	16	1	-	22	Black	GND
-	15	-	1	22	Red	12V

Note:
 All other pins are unloaded.
 CON2.16 loaded with two wires in one crimp.

REV. NO.	A	B	C	D	E	F	G	H	I	J	K	L	M	N	O	P	Q	R	S	T	U	V	W
ISSUE NO.																							
DATE	04/03/2010																						
DESIGNED BY																							
CHECKED BY																							
DATE																							
TITLE	RS232 to Validator Cable Assembly											MATERIAL		FINISH									
ISSUE NO.	1																						
DATE	04/03/2010																						
CHECKED BY	PNewton																						
DATE																							
TITLE	RS232 to Validator Cable Assembly																						
ISSUE NO.	1																						
DATE	04/03/2010																						
CHECKED BY	PNewton																						
DATE																							
TITLE	RS232 to Validator Cable Assembly																						
ISSUE NO.	1																						
DATE	04/03/2010																						
CHECKED BY	PNewton																						
DATE																							

All parts must be rated to at least UL94-VW1
 All connector housings must be rated to UL94-V0

2009 © Copyright of Innovative Technology Ltd
 All dimensions in mm ±0.5mm

NOT TO SCALE



10.4.7 CN487

FORMING NO. **CN487**

SIZE **C3**

Parts List

Item	QTY	Description	Vendor
A	1	39-01-2165 housing	Molex
B	6	(2x 8 way 4.2mm pitch Mini-FIT Jr receptacle) 0039000209 (tin plated, female, brass) crimps (4A @ 22AWG, 2N@26AWG)	Molex
C	1	Ferrite (2 turns)	-
D	1	20mm black heat shrink sleeve	-
E	6	(Spread along the length)	-
F	5	Standard AWG 28 wire (see comments below)	-
G	2	Standard AWG 22 wire	-
H	1	90142-0016 housing	Molex
I	1	(2x8way 2.54mm pitch receptacle)	Molex
J	3	90119-0120 (tin plated) crimps	Molex
K	1	Stackable black 4mm banana plug (553-0500-01)	Deltron
L	1	Stackable red 4mm banana plug (553-0500-01)	Deltron

Connectivity

CON1	Ferrite	CON2	CON3	CON4	Gauge (AWG)	Colour	Comment
Pin 1	1 loop	Pin 1	Pin 1	Pin 1	26	White	SSP TXD (Validator to Host)
Pin 16	1	Pin 1	Pin 1	Pin 25	26	Blue	SSP RXD (Host to Validator)
Pin 7	1	Pin 5	Pin 1	Pin 22	22	Red	V IN
Pin 14	1	Pin 9	Pin 1	Pin 22	22	Black	GND

Notes
 Pins 16 and 7 on CON1 are linked together.
 Pins 14 and 5 on CON1 are linked together.

Ferrite Sleeve
 Ferrite sleeve needs to have >572Ω @ 100MHz.
 Recommended parts:
 a) Wurth 74270050 - 714Ω @ 100MHz (two turns)
 b) Edger FL8 RH10 x 20 x 6.35 - 724Ω @ 100MHz (two turns)

Comments
 CON1 connects to Smart Ticket
 CON2 connects to Host
 CON3 connects to V- (GND)
 CON4 connects to V+ (12V or 24V)

For Item F, 2 wires are short links for pins 16 and 7 and pins 14 and 5 on CON1; 2 wires are from CON1 to CON2, and 1 wire is from CON2 to the soldered interconnection.
 CON3 and CON4 are for powering up the NV200 so V+ can be connected to 12V or 24V

Notes:
 1 turn = threaded through ferrite sleeve
 2 turns = threaded through with one loop

Notes:
 Soldered together
 To CON2, 16 (22AWG)
 To CON1, 1 (22AWG)
 To CON3, 1 (22AWG)

Note: Maximum notch height = 1.5mm

Smart Ticket/Payout to Host assembly (customer)

Manufacturer Information:
 INNOVATIVE TECHNOLOGY LTD
 3rd Floor, Persimmon
 Kingsway, C2 4AD
 TEL: 01461 711535
 FAX: 01461 711536
 WWW: WWW.ITL.CO.UK

Revision History:

REV	DATE	DESCRIPTION
A	31/01/2012	Initial release
B	31/01/2012	Revised drawing
C	31/01/2013	Revised drawing

Approval:
 DRAWN BY: A Lunsong
 CHECKED BY: A Lunsong
 DATE: 31/01/2012

Material:
 MATERIAL: Housing made to order to IL 94V0. Metal to be confirmed.

Other Info:
 ISSUE NO: C3
 MFG NO: 31012013
 DATE: 31/01/2013
 MFG NO: A Lunsong

Dimensions:
 All dimensions are in mm ±5mm, unless specified



NV200 Family User Manual

[<< Back to Contents](#)

10.4.8 WR147

DRAWING NO. **WR147**
ISSUE **A1**

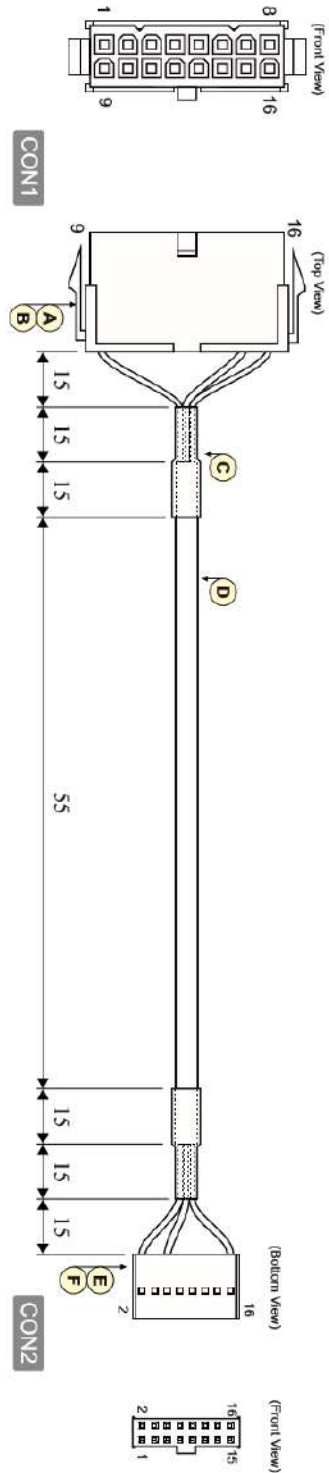

Parts List

Item	QTY	Description	Vendor
A	1	0039012166 plug housing (2x8way 4.2mm pitch Mini-Fit Jr)	Molex
B	4	0039000126 male crimp (phosphor bronze, tin plated, 18-24AWG)	Molex
C	2	30mm long, black heat shrink sleeve	-
D	1	4-core AWM style 2462 22AWG cable	-
E	1	90142-0016 housing	Molex
F	4	(2x8way 2.54mm pitch with key) 9733272 tin plated crimp	Molex

Connectivity		Gauge (AWG)	Colour	Comments
CON1	Pin			
	1	24	White	SSP_TXD (Vend1)
	16	24	Green	SSP_RXD_(Inhibit)
	14	24	Red	V_IN
	9	22	Red	
	1	24/22	Black	GND

Note to Manufacturers
Certificates are needed for the following:
 ■ RoHS compliance ■ UL94-V0 rated (connector housing) ■ UL94-VW1 rated (all other parts)



Smart Payout to NV200 adapter harness

REV	DATE	DESCRIPTION	BY	CHKD	APP'D
A	02/10/12	Initial Issue	A Lunsong		

REV	DATE	DESCRIPTION	BY	CHKD	APP'D
A1	02/10/12	Initial Issue	A Lunsong		

All dimensions are in mm ±0.1mm, unless specified



[<< Back to Contents](#)

10.5 Switching to Programming Mode (SSP)

If fitted remove the Payout or Ticket modules. Power the NV200, once the unit has initialised toggle **dip-switch 8** up and down.

To switch the unit back repeat the procedure explained above.

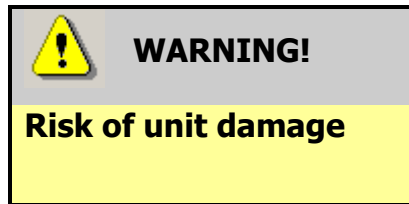

When in programming mode and performing an update, do not turn off the power before the operation is complete as this could make the unit unusable.

10.6 Changing the cashbox flag in the NV200

If the NV200 is configured for the wrong cashbox this is changed using validator manager, connect to the unit as outlined in [Section 6.3.1](#); navigate to the 'Options' tab, select Cashbox Type from the right hand side and select the appropriate cashbox from the dropdown. Click apply changes; the unit will reset with the applicable cashbox setting.

10.7 Free Fall Cashbox Advice

The NV200 cashbox and TEBS cash bag have been designed to remain intact after an impact of 75cm onto a concrete floor. Dropping the cashbox multiple times can result in physical damage to the cashbox/bag.

10.8 ccTalk DES Encryption – Trusted Mode

Ensure the NV200 has been configured to use DES encryption in Validator Manager, this setting can be found on the options tab. To pair the NV200 with a DES trusted machine please follow the steps below:

1. Remove power from the unit then remove the cashbox
1. Re-power the unit, once the unit has started it should be in pairing mode.

If a Smart Payout module is connected the unit must be empty before it can pair to the host.

10.9 Escrow

The NV200 has a single note escrow facility. This allows the NV200 to hold onto the note once validated, and only stack the note into a cashbox when the host machine confirms that the Vend operation has been completed. If no confirmation of the Vend is received, the note will be returned to the user after 30 seconds.

If the host machine itself aborts the transaction by sending the reject command (0x08). Similar commands can be sent depending on the protocol used. For information relating to other protocols please contact support.

10.9.1 Multi-Escrow

When the Payout module is used it adds the ability to store up-to 20 notes in escrow, this is done by dynamically allocating certain positions on the tape to escrow. As slots are assigned dynamically it means when the transaction is completed notes don't need to move to a different location thus the speed of the unit isn't affected.

For more details on the multi-escrow functionality please contact our support team.



NV200 Family User Manual

[<< Back to Contents](#)

10.10 ST Processor PCN

10.10.1 NV200

Innovative Technology Limited Product Change Notification

Product: NV200

PCN Issue Date		09/06/2016	
Notification Classification	➤ Mechanical	✓	
	➤ Electrical		
	➤ Electronic	✓	
	➤ Firmware		
	➤ Visual	✓	
Modification Introduction Date		09/06/2016	
Product Build Revision	NV200 H/W Rev 30	Document Author	James Beswick/ Ian Johnson
Previous Build Revision	NV200 H/W Rev 25		

Recommended Actions on

ITL Stock	None
Field Units	None
Apply to	New NV200 hardware release

Change details: NV200 Hardware Identification: Revision 30 (detailed below)

Includes:

Type	Hardware
Description	Release NV200 with the ST chipset
Reason	The new chip has been implemented as the old chip has become obsolete.
Effect/Impact	No change to the NV200 function and technical requirements. This version of NV200 requires a different version of firmware (issued under separate PCN). A different dataset type is also required (see below).



Innovative Technology Limited Product Change Notification

Label identification:

1. It has been up-issued to Revision 30
2. The NV200 with ST chipset will have its own 'validator type' referenced in the dataset name (see below):

Previous NV200 - GBP58620

NV200 with ST chipset - GBP58G20



NV200 Family User Manual

[<< Back to Contents](#)

10.10.2 Smart Payout

Innovative Technology Limited Product Change Notification

Product: NV200 & Smart Payout

PCN Issue Date		08/09/2016
Notification Classification	➤ Mechanical	
	➤ Electrical	✓
	➤ Electronic	✓
	➤ Firmware	✓
	➤ Visual	
Modification Introduction Date		08/09/2016
Product Build	NV200: 30	Document Author James Beswick
Revision	SPO: 41	
	F/W: 4/5.42	

Recommended Actions on

ITL Stock	None
Field Units	None
Apply to	N/A

Change details: Smart Payout Revision 41

Identification: Label Identifier

Includes:

Type	Hardware
Description	New Main board (PA02688 as opposed to PA02577)
Reason	The new chip has been implemented as the old chip has become obsolete.
Effect/Impact	No change to the Smart Payout function and technical requirements. This version of Smart Payout requires a version of firmware 4/5.42 and above.

Change details: Changes from 4/5.40 -> 4/5.42 firmware

Identification: Firmware string: `_NV02004422000 / _NV02005422321000`

Includes:

Type	Firmware
Description	Critical update to add compatibility for ST Smart Payout modules
Reason	Release of R41 Smart Payouts
Effect/Impact	No impact, adding support for ST chipsets



NV200 Family User Manual

[<< Back to Contents](#)

Innovative Technology Limited Product Change Notification

Type	Firmware
Description	Reverse validation improvements with high speed firmware
Reason	With the high speed firmware, we observed a higher number of reverse validation fails than we would come to expect, as such we reduced the speed of the reverse from escrow to payout, this has led to a more consistent reading.
Effect/Impact	Improved field reliability

Type	Firmware
Description	Bezel goes solid red if a note has been inserted during the stacking process
Reason	The lack of visual queue from the unit led to customers trying to put in notes prematurely, when a note is inserted during the stacking/storing process it is paused and the bezel goes solid red.
Effect/Impact	N/A

Type	Firmware – TEBS ONLY
Description	TEBS unit is now able to be unlocked when in a startup error state
Reason	Added in the event a TEBS unit encountered a critical issue in the field and was unrecoverable.
Effect/Impact	N/A

Type	Firmware
Description	SPF3 Calibration Improvements
Reason	Improved calibration routines in SPF3.
Effect/Impact	Improved field performance.



10.11 File Naming Convention

ITL use a file naming system so dataset/firmware files can be identified and the correct file for the current Validator can be selected, this is especially relevant due to the recent move to the ST processor. Below is an explanation of the file naming convention as well as information on the file names which relate to the NV200 family.

EUR01610_NV02004161551000_IF_01.bv1

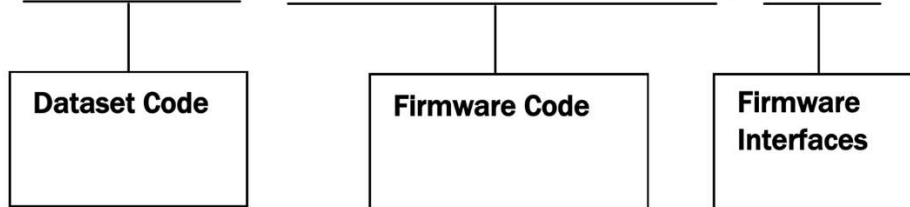

Dataset Code

EUR 01 6 10

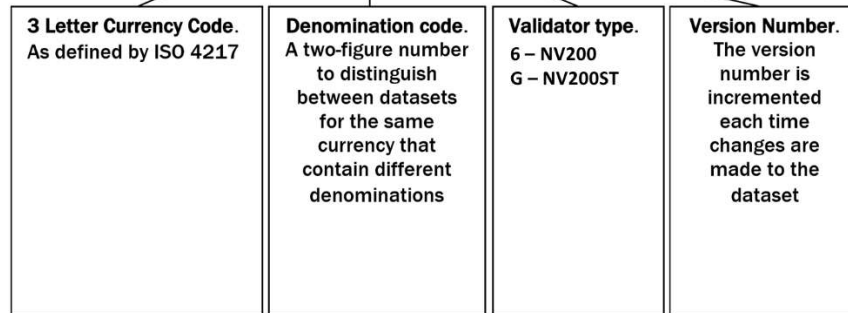

Firmware Code

NV0200 416 1551000

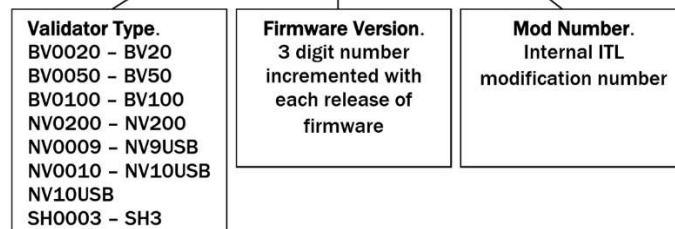

Firmware Interfaces

IF_01

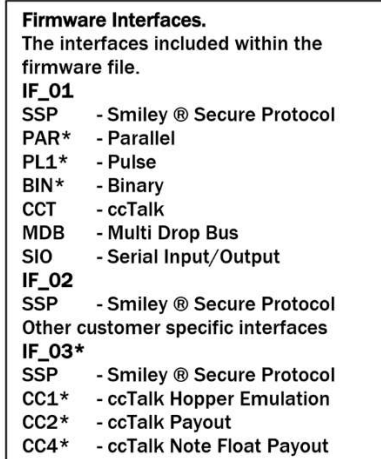

* - Only available for specific Validators

